



**Invitation to Bid, No. 24-012**

**ITB 2024 CDBG ADA Ramp/Sidewalk Repair/Replace  
June 26, 2024**

**PRE-BID MEETING**

**Wednesday, July 03, 2024, at 11:00 A.M. EST.**

**City of Brookhaven – 4362 Peachtree Road NE, Brookhaven, GA 30319**

**QUESTIONS DUE**

**July 10, 2024, 4:00 PM**

**BID DUE DATE:**

**July 24, 2024, at 4:00 P.M. EST.**

**Bids shall only be accepted online through the Bonfire Portal at:**

**<https://brookhavenga.bonfirehub.com/projects/view/144608>**

**Any bid submitted in any other format (email, paper, fax, mail, etc.) will not be accepted.**

**Instructions to Bidders:**

1. All communication regarding this solicitation must be with the Purchasing Manager, Purina Alexander, [purina.alexander@brookhavenga.gov](mailto:purina.alexander@brookhavenga.gov).
2. All questions or requests for clarification must be sent via Bonfire under Message - Opportunity Q&A: <https://brookhavenga.bonfirehub.com/projects/view/144608>. Questions are due no later than **July 10, 2024, at 4:00 p.m. EST**. Questions received after this date and time may not be answered.
3. All questions and clarifications from bidders shall be answered via an addendum. Any addenda, schedule changes, and other important information regarding this solicitation will be posted at <https://brookhavenga.bonfirehub.com/projects/view/144608> the bonfire website, and is the bidder's responsibility to check the Bonfire portal for any addendum or other communications related to this solicitation.
4. The City of Brookhaven reserves the right to reject all bids, waive technicalities and informalities, and make an award in the best interest of the City of Brookhaven.
5. The City of Brookhaven is not responsible for any technical difficulties. It is highly recommended that all potential contractors submit their quotes before the due date of this solicitation, **July 24, 2024**.

6. The City of Brookhaven reserves the right to eliminate certain pay items from the contract if the cost of those items exceeds the project budget. In turn, the City of Brookhaven reserves the right to add pay items to the contract at the bid price submitted by the awarded contractor.

All bidders must comply with the general requirements, special and Federal provisions of the bid information, and instructions enclosed. Interested bidders need to review all bid documents carefully. The 2024 ADA RAMP/SIDEWALK REPAIR/REPLACE project is being funded by a Community Development Block Grant (CDBG) made available to the City of Brookhaven through a partnership with the U.S. Department of Housing and Urban Development (HUD). Consistent with other Federal programs, CDBG requires compliance with various federal laws, regulations, and guidelines throughout the Invitation to Bid procurement process, project construction, and project close-out. **Important laws and regulations the successful contractor and subsequent subcontractors must comply with include, but are not limited to, the following:**

- Title VII of the Civil Rights Act of 1964 and Executive Order 11246.
- 24 CFR Part 85.36 Conflict of Interest provisions.
- 24 CFR Part 85(e) Minority, Women-owned, Small Business Enterprise.
- 29 CFR Parts 1, 3, 5, 6, and 7 Davis-Bacon Act.
- 40 U.S.C. 327-333 Contract Work Hours and Safety Standards Act.
- 24 CFR Part 135 Section 3.

Attention is paid to the fact that this project is being funded ultimately through the Community Development Block Grant (CDBG) Program of the U.S. Department of Housing and Urban Development. The bidder is asked to pay special attention to the Federal Regulations included in the bid package. These regulations include The Davis-Bacon Act, Section 3, the Contract Work Hours and Safety Standards Act, the Copeland (Anti-Kickback Act), and the Fair Labor Standards Act. In addition, the contractor must comply with the terms and conditions of:

CDBG Supplemental Conditions have been attached to these Contract Documents and supersede the requirements of the General Conditions of this contract. Included in the CDBG Supplemental Conditions is the applicable Federal Department of Labor - Wage Rate Decision to be utilized in the payment of all persons employed relative to the construction of this project.

CDBG Federal/Local Conditions are attached as an addition to these Contract Documents and supersede all requirements in these documents.

**These CDBG Requirements Include the Following:**

- 1) Section 109 of the Fair Housing and Equal Opportunity Act of 1974; Title VI and other applicable provisions of the Civil Rights Act of 1964.
- 2) The Fair Housing and Equal Opportunity Act, as amended.
- 3) CDBG Program regulations on conflict of interest.
- 4) Federal staff and auditor's access to records.
- 5) Executive Order 11246, Equal Employment Opportunity.
- 6) The Department of Labor Equal Opportunity Clause (41 CFR 40-1, 4).
- 7) Executive Order 11625 (Utilization of Minority and Female Business Enterprises).
- 8) Section 504 of the Rehabilitation Act of 1973 and the American Disabilities Act of 1990.
- 9) CDBG Supplemental Conditions have been attached to these Contract Documents and supersede the requirements of the General Conditions of this contract. Included in the CDBG Supplemental Conditions is the applicable Federal Department of Labor - Wage Rate Decision to be utilized in the payment of all persons employed relative to the construction of this project.
- 10) Bidders must be registered at **Sam.gov**. Bidders are not required to have a Sam.gov issued Unique Identifier Number (UIN) at the time of bid. However, at a minimum, bidders must provide confirmation of application for a UIN with bid submission. Successful bidder will be required to have a UIN prior to contract award.

## TABLE OF CONTENTS

1. Definitions: [Page 3](#)
2. Sample Contract Agreement: [Pages 4-6](#)
3. General Conditions. [Exhibit A: Pages 7-30](#)
4. Specifications and Scope of Work (ITB 24-XXX reference herein.) [Exhibit B: Pages 31-37](#)
5. Determination of Responsibility. [Exhibit C: Page 38](#)
6. Bond Documents: Payment Bond, Performance Bond, and Maintenance Bond. [Exhibit D: Pages 39-46](#)
7. Georgia Security and Immigration Compliance Affidavit. [Exhibit E: Pages 47-48](#)
8. Drug-Free Workplace. [Exhibit F: Page 49](#)
9. Purchasing Policy Addendum. [Exhibit G: Page 50](#)
10. Affidavit Verifying Status for Public Benefit Application. [Exhibit H: Page 51](#)
11. Bid Documents: References and Subcontractor Form. [Exhibit I: Pages 21-53](#)
12. Non-Collusion Affidavit. [Exhibit J: Page 54](#)
13. Bid Schedule. [Exhibit K: Pages 55-60](#)
14. Task 1: Location, Details, & Specifications; [Exhibit L: Pages 61-70](#)
15. Task 2: Location, Details, & Specifications; [Exhibit M: Pages 71-78](#)
16. CDBG Federal/Local Project Requirements. [Exhibit N: Pages 79-80](#)
17. A Standard Federal-Aid Contract for Locally Administered or Locally Let Projects – [Exhibit O: Pages 81-197](#)

## DEFINITIONS

**ADA:** Americans with Disabilities Act: This Federal Act gives civil rights protections to the disabled like those provided to individuals based on race, color, sex, national origin, age, and religion. It guarantees equal opportunity for individuals with disabilities in public accommodations, employment, transportation, and state and local government services telecommunications.

**CDBG:** Community Development Block Grant Program.

**CWHSSA:** Contract Work Hours and Safety Standards Act. The Federal Act requires time and one-half for overtime (O/T) hours (over 40 hours in any workweek) worked on the covered project.

**Copeland Act (Anti-Kickback Act):** the Federal Act that makes it a federal crime for anyone to require any laborer or mechanic (employed on a Federal or Federally assisted project) to kickback (i.e., give up or pay back) any part of their wages. The Copeland Act requires every employer (contractors and subcontractors) to submit weekly payroll reports (CPRs) and regulates permissible payroll deductions.

**DBA-Davis Bacon Act:** The Federal Act requires the payment of prevailing wage rates, determined by the Department of Labor (DOL), to all laborers and mechanics on Federal government and District of Columbia construction projects more than \$2,000. Construction includes alteration and or repair, including painting and decorating, of public buildings or public works.

**CONTRACT FOR ITB 24-012**

**2024 ADA RAMP/SIDEWALK REPAIR/REPLACE**

**CDBG FEDERAL FUNDED PROJECT**

This **CONTRACT**, made and entered into this \_\_\_\_ day of \_\_\_\_\_, 2024 by and between the City of Brookhaven, (Party of the First Part, hereinafter called the “City”), and - \_\_\_\_\_, Party of the Second Part, hereinafter called the “Contractor Provider” or “Contractor”).

**NOW THEREFORE**, for and in consideration of the mutual promises and obligations contained herein and under the conditions hereinafter set forth, the parties do hereby agree as follows:

**1. TERMS:**

The Services performed under this Contract shall commence upon the date stated in the Notice to Proceed Letter. The contract period for this contract is 90 days from the date stated in the Notice to Proceed Letter. Upon the completion of the full scope of work, the contract shall terminate absolutely and without further obligation as required by O.C.G.A. §36-60-13, as amended, unless terminated earlier by the provisions of this Contract.

**2. ATTACHMENTS:** The following documents are attached and are specifically incorporated herein by reference; and, along with this Contract and the General Conditions attached as **Exhibit A** encompass all the **Contract documents:**

Exhibit A: General Conditions.

Exhibit B: Specifications and Scope of Work (ITB 24-012 reference herein).

Exhibit C: Determination of Responsibility.

Exhibit D: Bond Documents: Payment Bond, Performance Bond, and Maintenance Bond.

Exhibit E: Georgia Security and Immigration Compliance Affidavit.

Exhibit F: Drug-Free Workplace.

Exhibit G: Purchasing Policy Addendum.

Exhibit H: Affidavit Verifying Status for Public Benefit Application.

Exhibit I: Bid Documents: References and Subcontractor Form.

Exhibit J: Non-Collusion Affidavit.

Exhibit K: Bid Schedule.

Exhibit L: CDBG FEDERAL/LOCAL PROJECT REQUIREMENTS.

Exhibit M: A Standard Federal-Aid Contract for Locally Administered or Locally Let Projects.

**3. PERFORMANCE:**

The Contractor Provider agrees to furnish all skill and labor of every description necessary to carry out and perform the services per the Contract Documents (the “Work”).

**4. PRICE:**

The City agrees to pay the Contractor Provider following receipt by the City of a detailed invoice reflecting the actual work performed by the Contractor Provider, provided that the Contractor Provider guarantees that the maximum price for materials, labor, and expenses, shall be the amount reflected in Exhibit K.

**5. INDEMNIFICATION AND HOLD HARMLESS:**

**[See Section 13 of Exhibit A. -- General Conditions]**

Contractor Provider further agrees to protect, defend, indemnify, and hold harmless the City, its council members, officers, agents, and employees from and against all claims or liability for compensation under the Worker’s Compensation Act arising out of injuries sustained by any employee or subcontract of the Contractor Provider, as allowed under the law.

**6. TERMINATION FOR CAUSE:**

The City may terminate this Contract for cause upon ten (10) days prior written notice to the Contractor Provider of the Contractor Provider's default in performance in any terms of this Contract. Such termination shall be without prejudice to any City's rights or remedies provided by law.

- 7. TERMINATION FOR CONVENIENCE:** The City may terminate this Contract for its convenience at any time upon 30 days written notice to the Contractor Provider. In the event of the City's termination of this Contract for convenience, the Contractor Provider will be compensated for those services performed. Partially completed performance of the Contract will be compensated based upon a signed statement of completion to be submitted by the Contractor Provider who shall itemize each element of performance.

**8. TERMINATION FOR FUND APPROPRIATION:**

The City may unilaterally terminate this Contract due to lack of funding at any time by written notice to the Contractor Provider. In the event of the City's termination of this Contract for fund appropriation, the Contractor Provider will be paid for those services performed. Partially completed performance of the Contract will be compensated based upon a signed statement of completion to be submitted by the Contractor Provider which shall itemize each element of performance.

**9. CONTRACT NOT TO DISCRIMINATE:**

During the performance of this Contract, the Contractor Provider will not discriminate against any employee or applicant for employment because of race, creed, color, color, sex, national origin, age, or disability which does not preclude the applicant or employee from performing the essential functions of the position. The Contractor Provider will also, in all solicitations or advertisements for employees placed by qualified applicants, consider the same without regard to race, creed, color, sex, national origin, age, or disability which does not preclude the applicant from performing the essential functions of the job. The Contractor Provider will cause the foregoing provisions to be inserted in all subcontracts for any work covered by this Contract so that such provision will be binding upon each subcontractor for standard commercial supplies of raw materials.

**10. ASSIGNMENT:**

The Contractor Provider shall not sublet, assign, transfer, pledge, convey, sell, or otherwise dispose of the whole or any part of this Contract or their right, title, or interest therein to any person, firm, or corporation without the previous consent of the City in writing.

**11. WAIVER:**

A waiver by either party of any breach of any provision, term, covenant, or condition of this Contract shall not be deemed a waiver of any subsequent breach of the same or any other provision, term, covenant, or condition.

**12. SEVERABILITY:**

The parties agree that each of the provisions included in this Contract is separate, distinct, and severable from the other and remaining provisions of this Contract and that the invalidity of any Contract provision shall not affect the validity of any other provision or provisions of this Contract.

**13. GOVERNING LAW:**

The parties agree that this Contract shall be governed and construed per the laws of the State of Georgia. This Contract has been signed in DeKalb County, Georgia.

**14. MERGER CLAUSE:**

The parties agree that the terms of this Contract included the entire Contract between the parties, and as such, shall exclusively bind the parties. No other representations, either oral or written, may be used to contradict the terms of this Contract.

**15. SMALL AND MINORITY BUSINESSES CLAUSE:**

The City of Brookhaven, in maintaining its status as a Welcoming City and City of Ethics, commissioned a study of its Social Justice, Race, and Equity practices. As a result of the study, recommendations have been made to the Brookhaven City Council to enhance and improve upon its efforts in providing opportunities to small and minority businesses in procuring goods and services. With respect to openness and transparency, the City of Brookhaven encourages all businesses regardless of size and status to engage in the City’s procurement process. The City gives equal attention to all submissions and will collaborate with individual firms to ensure that their questions are answered on a timely basis.

**IN WITNESS WHEREOF**, the parties hereto, acting through their duly authorized agents, have caused this **CONTRACT** to be signed, sealed, and delivered.

**Brookhaven, GEORGIA**

By: \_\_\_\_\_  
John Park, Mayor, City of Brookhaven, Georgia

ATTEST: \_\_\_\_\_  
Sandra Bryant, City Clerk

APPROVED AS TO FORM: \_\_\_\_\_  
Jeremy Berry, City Attorney

**Contractor**

By: \_\_\_\_\_  
(Signature)  
\_\_\_\_\_  
(Print Name)  
\_\_\_\_\_  
(Print Title)

Date \_\_\_\_\_

ATTEST: \_\_\_\_\_  
(Signature)  
\_\_\_\_\_  
(Print Name)  
\_\_\_\_\_  
(Print Title)

Date \_\_\_\_\_

**EXHIBIT A**  
**GENERAL CONDITIONS**

**1. SCOPE OF WORK**

The Contract shall provide Contractors to the City in accordance with the Contract Documents. All work performed shall be in accordance with the Scope of Contractors attached hereto as **Exhibit B.**

**2. REGULATIONS**

**2.1** The Contractor Provider shall comply with all applicable federal, state, and local laws, ordinances, rules, and regulations pertaining to the performance of the work specified herein.

**2.2** The Contractor Provider shall obtain all permits, licenses, and certificates, or any such approvals of plans or specifications as required by federal, state, and local laws, ordinances, rules, and regulations, for the proper execution of the work specified herein.

**2.3** During the performance of this Contract, the Contractor Provider shall keep current and, if requested by the City, provide copies of all licenses, registrations or permits required by applicable governing agencies, The Contractor Provider shall keep a copy of all licenses, registrations and permits on the job site while performing the Contract work.

**2.4** The Contractor Provider will comply with the City of Brookhaven's Financial Management and Purchasing Policies.

**2.5** Contractor Provider will complete all work in accordance with all applicable legal requirements, including, but not limited to O.C.G.A. § 50-5-63, as applicable.

**3. WORK HOURS**

**3.1** The Contractor shall normally perform on-site work during Standard work hours, which are between 7:00 a.m. and 7:00 p.m., Monday through Friday, excluding City's observed holidays. The City may require the Contractor to perform work on the City's premises during non-Standard work hours which are outside the Standard work hours. Nonstandard Work Hours may be arranged with prior written approval of the City. The Contractor shall advise the City no less than 48 hours in advance of its projected work schedule. The Contractor shall perform no work during City observed holidays without the prior written permission of the City.

**3.2** In the event an emergency condition is declared by the City's Manager, or their respective designee, the Contractor will perform work during such hours as requested by the City.

**3.3** The City may order the Contractor Provider to suspend, delay, or interrupt all or any part of the work for such a period as may be determined appropriate for the convenience of the City. The time for completion of the work shall be extended by the number of days the work is suspended. The City shall not be responsible for any claims, damages or costs stemming from any delay of the work.

**EXHIBIT A**  
**GENERAL CONDITIONS**

**4. CONTRACTOR PROVIDER'S PERSONNEL**

- 4.1** The Contractor Provider will abide by all State and Federal regulations on wages and hours of an employee dealing with the employment relationship between the Contractor Provider and its subsidiaries or related parties and its employees, including but not limited to the Federal National Labor Relations Act, the Federal Fair Labor Standards Act, the Federal Civil Rights Act of 1964, as amended, and the Americans with Disabilities Act.
- 4.2** The Contractor Provider shall require all prospective employees to show proof of citizenship, or proof from the United States Immigration and Naturalization Contractor of valid entry permits and/or work permits for legal aliens and proof that such legal aliens are eligible to be employed in the United States. This includes any requirement for participation in the DHS e-Verify or SAVE program.
- 4.3** Should the Contractor Provider engage employees who are illiterate in English, it will be the Contractor Provider's responsibility and obligation to train such employees to be able to identify and understand all signs and notices in and/or around the areas that relate to them, or the services being performed by them pursuant to this Contract. In addition, the Contractor Provider will always have someone in attendance who can communicate instructions to said employee.
- 4.4** The Contractor Provider shall maintain a Drug-free workplace within the meaning of the Georgia Drug-free Workplace Act. No employee shall be hired by a Contractor Provider for work on the City's premises prior to such employee having tested negative for Drugs. In addition, existing employees must have tested negative for Drugs and must be subject to Drug testing by the Contractor Provider upon reasonable suspicion of Drug use. Results of all such Drug tests are to be retained by the Contractor Provider. Copies shall be provided to the City, if requested.
- 4.5** The Contractor Provider shall transfer promptly from the City any employee or employees that the City advises are not satisfactory and replace such personnel with employees satisfactory to the City; but in no event shall the City be responsible for monitoring or assessing the suitability of any employee or agent of the Contractor Provider.
- 4.6** The Contractor Provider's employees shall be instructed that no gratuities shall be solicited or accepted for any reason whatsoever from the tenants, customers, or other persons in the City.
- 4.7** A valid Driver license (Commercial Driver License, if applicable) will be required of all personnel operating motor vehicles or motorized equipment on roadways in or around the City.
- 4.8** While working on City property all Contractor Provider's employees shall wear neat appearing business casual attire or uniforms with the company name and/or logo and footwear of a style that complies with all legal and safety requirements, including and without limitation, the requirements of OSHA.
- 4.9** Designation of a supervisor by the Contractor Provider shall designate an experienced supervisor ("supervisor") acceptable to the City for all purposes related to the work. The initial supervisor, and his/her contact information, is to be provided at the pre-construction meeting after the award of the bid.



**EXHIBIT A**  
**GENERAL CONDITIONS**

**4.9.1** The Supervisor shall be fully responsible for the Contractor Provider meeting all its obligations under this Contract. The Supervisor shall provide the City with an appropriate bi-weekly status report on the progress of the project.

**4.9.2** The Supervisor shall be available, as reasonably required, to be on-site during necessary times. Such times shall be discussed between the Supervisor and the City, but the final required times will be at the City's discretion.

**4.9.3** In the event that the designated Supervisor terminates employment with the Contractor Provider or is requested by the City to be removed from the role of Supervisor (as provided in Section 4.5), the position shall be assumed by an individual with equivalent qualifications, experience, and knowledge. Such replacement shall require the City's prior approval.

**4.10** The process by which the implementation partner requests the removal of a team member from the project. If a Contractor Provider replaces a proposed team member, the Contractor Provider shall replace that team member with one of similar experience. The City reserves the right to accept or reject any proposed or replacement team member, with or without cause, at any time during the duration of the project.

**5. TOOLS AND EQUIPMENT**

It shall be the sole responsibility of the Contractor Provider to provide all tools, parts, and mechanical and non-mechanical equipment necessary to perform work under this Contract.

**6. PERFORMANCE REQUIREMENTS**

**6.1** The Contractor Provider shall perform all its obligations and functions under the Contract in accordance with the Contract specifications and industry standards. The Contractor Provider shall adjust and coordinate its activities to the needs and requirements of the City and perform its activities so as not to annoy, disturb, endanger, unreasonably interfere with, or delay the operations or activities of the City.

**6.2** The Contractor Provider's personnel shall perform work in compliance with all Federal, State, and City of Brookhaven regulations.

**6.3** Dates for commencement and completion of work shall be coordinated with the City's Authorized Representative (CAR).

**6.4** Any work required beyond that which is specified herein shall be reported in advance to the City. At no time shall work beyond the scope be performed without prior written authorization from the City.

**6.5** The Contractor Provider shall utilize maximum safety procedures. Tools and equipment shall be in a good state of repair, safe to use, and be used in the way they were intended. The Contractor Provider is required to inform all workers and concerned people of the Material Safety Data information on all products being utilized on this project. No materials or equipment shall be left unattended at any time.

**EXHIBIT A**  
**GENERAL CONDITIONS**

**7. CONFIDENTIAL INFORMATION**

- 7.1** In the course of performing the contract work, if required, the Contractor Provider may gain access to security-sensitive areas and sensitive information belonging to the City, only with specific written authorization by the city manager or their authorized designee.
- 7.2** The Contractor Provider agrees to hold all City data and information in confidence and to make such information known only to its employees and subcontracts who have a legitimate need to know such information and only after advising such persons of the Contractor Provider's non-disclosure obligations.
- 7.3** The Contractor Provider shall seek the City's prior written consent before using for any purpose other than the fulfillment of the Contractor Provider's obligations hereunder, or before releasing, disclosing, or otherwise making such information available to any other person.
- 7.4** The Contractor Provider shall employ such practices and take such actions to protect the City's information from unauthorized use and/or disclosure as the Contractor Provider employs and takes to protect its own information, but in no event shall the Contractor Provider use less than reasonable efforts to protect the City's information.
- 7.5** The provisions of this Section shall survive the expiration or earlier termination of the Contract.

**8. USE OF PREMISES**

During the progress of the work specified herein, to the extent any work is performed on the City's premises, the Contractor Provider shall keep the premises free from accumulation of waste materials and other debris resulting from work about the premises including tools, equipment, machinery, and surplus materials. The Contractor Provider shall leave the site clean and ready for occupancy by the City at the end of each workday.

**9. SAFETY AND PROTECTION**

The Contractor Provider shall be solely and completely responsible for initiating, maintaining, and supervising all safety precautions for the safety of, and shall provide the necessary protection to prevent damage, injury, or loss to all employees on the worksite and other persons including, but not limited to, City employees and any members of the public who may be affected thereby.

**10. COMPENSATION – INVOICE AND PAYMENT FOR CONTRACTOR SERVICES**

- 10.1** The City shall pay the Contractor Provider, subject to any authorized deductions, the applicable prices set forth for each service authorized by the City and delivered or performed by the Contractor Provider to the satisfaction and acceptance, as appropriate, of the City. The timing of such payments shall be as set forth below in the Section.
- 10.2** The Contractor Provider shall invoice, including all supporting documentation and backup material that the City may reasonably require, and provide the Proof of

**EXHIBIT A**  
**GENERAL CONDITIONS**

Payment attached as an Exhibit hereto, indicating, with each invoice, that all subcontractors have been paid.

- 10.3** The Contractor Provider shall deliver to the City, approval, and acceptance, before eligible for final payment of any amounts due, all documents and materials prepared by the Contractor Provider for the City under this Contract.
- 10.4** The City shall pay the undisputed amount of the Contractor Provider's invoice, as it may be reduced to reflect unsubstantiated or unsatisfactory service. Items in dispute shall be paid upon the resolution of the item(s) in dispute. No verification, nor payment of any amounts invoiced shall preclude the City from recovering any money paid more than that due under the terms of this Contract.
- 10.5** The Contractor Provider shall be obligated to pay promptly all proper charges and costs incurred by the Contractor Provider for labor and expenses incurred for the work performed hereunder. The City shall have the right, but not the obligation, to pay directly to third parties (including subcontractors) all past due amounts owed by the Contractor Provider to third parties for labor and materials used for the work hereunder, based on invoices submitted by such third party, and all such amounts paid by the City shall be applied toward and shall reduce, the amount owed to Contractor Provider hereunder.
- 10.6** The Contractor Provider must submit all invoices electronically to the City of Brookhaven Public Works Department at [pwadmin@brookhavenga.gov](mailto:pwadmin@brookhavenga.gov) and copy to [accountspayable@brookhavenga.gov](mailto:accountspayable@brookhavenga.gov). A City of Brookhaven assigned PO number, issued after the approval of the awarded Contract, must be included on all submitted invoicing.
- 10.7** The Contractor Provider will agree to comply with the City of Brookhaven's Financial and Purchasing Policies, to the extent applicable.
- 10.8** The Contractor Provider agrees that the compensation provided herein shall be a full and final settlement of all claims arising against the City of Brookhaven for the completed work, materials furnished, costs incurred, or other services arising from this contract, and shall release the City from all future claims related to the payment for the materials and services furnished in connection with this Contract.
- 10.9** The Contractor Provider and City agree that in any event a provision of this Contract the time of payment, the rate of payment, and any rates of interest differing from any provision of the Prompt Pay Act, are hereby waived, and said Contract provisions shall prevail. The City shall not be responsible for any interest penalties or late payments.

**11. COMPLIANCE WITH LAWS AND REGULATIONS**

- 11.1** The Contractor Provider shall perform its obligations and functions hereunder in compliance with the applicable laws of the United States, the State of Georgia, DeKalb County, the City of Brookhaven, any applicable rules, regulations, or directives of any agency thereof, and the applicable regulations of the City. OSHA rules and regulations shall always be followed. The City shall have the right (but not the obligation) to contest or challenge, by any means whatsoever, any law, regulation, rule, or directive which, in any way, affects or otherwise impacts upon the Contractor Provider's performance of its obligations and functions hereunder.

**EXHIBIT A**  
**GENERAL CONDITIONS**

The Contractor Provider shall fully cooperate and take whatever action (including becoming a party in any litigation) the City should reasonably request in connection with any such challenge or contest by the City.

**11.2** The Contractor Provider shall obtain and keep current all licenses, permits and authorizations, whether municipal, county, state, or federal, required for the performance of its obligations and functions hereunder and shall pay promptly when due all fees, thereof.

**11.3** The Contractor Provider shall abide by all applicable state and federal regulations concerning wages and hours of employees; **including, but not limited to, compliance with the requirements of O.C.G.A. 13-10-91 AND Rule 300-104-1-.02.**

**12. CONTRACTOR PROVIDER'S LIABILITY**

The Contractor Provider shall be responsible for the prompt payment of any fines imposed on the City or the Contractor Provider by any other federal, state, or local governmental agency because of the Contractor Provider, its subcontractors, or the officers, directors, employees, or agents of either party. Failure to comply with the requirements of any law, or any governmental agency rule, regulation, order, or permit. The liability of the Contractor Provider under this Section 12 is in addition to and is in no way a limitation upon any other liabilities and responsibilities which may be imposed by applicable law or by the indemnification provision of Section 13 hereof. Such liability shall survive the expiration or earlier termination of this Contract.

**13. INDEMNIFICATION AND INSURANCE**

**13.1** The Contractor Provider shall, to the extent allowed under Georgia law, indemnify, defend, and hold completely harmless the City, and the members, including, without limitation, members of the Brookhaven City Council, and board members of the City, officers, employees, and agents of each, from and against all liabilities (including statutory liability and liability under Workers Compensation Laws), losses, suits, claims, demands, judgments, fines, damages, costs and expenses (including all costs for investigation and defense thereof, including, but not limited to, court costs, paralegal and expert fees, and reasonable attorneys' fees) which may be incurred by, charged to, or recovered from any of the foregoing by:

- (i) Reason or on account of damage to or destruction or loss of any property of the City, or any property of, injury to or death of any person resulting from or arising out of or in connection with the performance of this Contract, or the acts or omissions of the Contractor Provider's directors, officers, agents, employees, subcontractors, licensees or invitees, in connection with the performance of this contract regardless of where the damage, destruction, injury or death occurred, unless such liability, loss, suit, claim, demand, judgment, fine, damage, cost or expense was proximately caused solely by the City's negligence or by the joint negligence of the City and any person other than the Contractor Provider

**EXHIBIT A**  
**GENERAL CONDITIONS**

or the Contractor Provider's directors, officers, agents, employees, subcontractors, licensees, or invitees, or:

- (ii) Arising out of, or in connection with, the failure of the Contractor Provider to keep, observe, or perform any of the covenants or agreements in this Contract which required to be kept, observed, or performed by the Contractor Provider, or:
- (iii) Arising out of or in connection with any claim, suit, assessment, or judgment prohibited by Section 13.4 below by or in favor of any person described in Section 13.5 below, or:
- (iv) Arising out of or in connection with any action by Contractor Provider or its directors, officers, agents, employees, subcontractors, licensees, or invitees. The City agrees to give the Contractor Provider reasonable notice of any suit or claim for which indemnification will be sought hereunder, to allow the Contractor Provider, or its insurer, to compromise and defend the same to the extent of its interest, and to reasonably cooperate with the defense of any such suit or claim. In carrying out its obligations under this section, the Contractor Provider shall engage counsel reasonably acceptable to the City in any suit, action, proceeding, claim, or demand brought in respect of which the City may pursue indemnity, the City shall have the right to retain its own counsel, but the fees and expenses of such counsel shall be at the expense of the City unless:
  - (i) The Contractor Provider and the City shall have mutually agreed to the contrary.
  - (ii) The Contractor Provider has failed within a reasonable time to retain counsel reasonably satisfactory to the City.
  - (iii) The City and the Contractor Provider are both named parties in any such proceeding and, in the sole judgment of the City, representation of both the City and the Contractor Provider by the same counsel would be inappropriate due to actual or potential differing interests between them. The indemnification provisions of Section 14 shall survive the expiration or earlier termination of this Contract with respect to any acts or omissions occurring during the term of the Contract. Notwithstanding anything contained in the foregoing indemnity, any claim for indemnity by the City for claims of thirds parties alleging harm due to the professional Contractor provided by Contractor Provider, to the fullest extent permitted by law, Contractor Provider shall indemnify City from and against losses, damages, and judgments arising from such claims by third parties, including reasonable attorneys' fees and expenses recoverable under applicable law, but only to the extent they are found to have been caused by a negligent act, error, or omission of Contractor Provider, or its sub-contractors, in the performance of professional services under this Agreement.

**EXHIBIT A**  
**GENERAL CONDITIONS**

- 13.2** In addition to indemnification provisions stated above, if the City's use of any Contractor, software, firmware, programming, or other item provided by or on behalf of the Contractor Provider is enjoined due to infringement of another person or entity's intellectual property rights, the Contractor Provider shall promptly, at its sole cost and expense, modify the infringing item so that it no longer infringes, procure for the City the legal right to continue using the infringing item, or procure for the City a non-infringing item, or procure for the City a non-infringing replacement item having equal or greater functional capabilities as the infringing item.
- 13.3** The Contractor Provider shall assume all responsibility for loss caused by neglect or violation of any state, federal, municipal or agency law, rule, regulation, or order. The Contractor Provider shall give to the proper authorities all required notices relating to its performance, obtain all official permits and licenses, and pay all proper fees and taxes. It shall promptly undertake proper monetary restitution with respect to any injury that may occur to any building, structure, or utility because of its work. The Contractor Provider will notify the City in writing of any claim made or suit instituted against the Contractor Provider because of its activities in the performance of the Contract.
- 13.4** No recourse under or upon any obligation, covenant or agreement contained in this Contract, or any other agreement or document pertaining to the work of the Contractor Provider hereunder, as such may from time to time be altered or amended in accordance with the provisions hereof, or any judgment obtained against the City, or by the enforcement of any assessment or by any legal or equitable proceeding by virtue of any statute or otherwise, under or independent of this Contract, shall be had against any member (including without limitation members of the City's Council, or members of the citizens advisory committees of each), any officer, employee or agent, as such, past, present, or future of the City, either directly or through the City or otherwise for any claim arising out of, or in connection with, this Contract or the work or services conducted pursuant to it, or for any sum that may be due and unpaid by the City. Any and all personal liability of every nature, whether at common law or in equity, or by statute or by constitution or otherwise, of any such member, officer, employee, or agent, as such, to respond by reason of any act or omission on their part or otherwise for any claim arising out of, or in connection with, this Contract or the work or services conducted pursuant to it, or for the payment for or to the City, or any receiver, therefore or otherwise, or any sum that may remain due and unpaid by the City, is expressly waived and released as a condition of and in consideration of the execution of this Contract and the promises made to the Contractor Provider pursuant to this Contract.
- 13.5** In any and all claims against the City, or any of their officers, members, agents, servants or employees, by any employee of the Contractor Provider, any subcontractor, anyone directly or indirectly employed by any of them or anyone for whose acts any of them may be liable, the indemnification obligation of the Contractor Provider under this Section 13 shall not be limited in any way by any

**EXHIBIT A**  
**GENERAL CONDITIONS**

limitation on the amount or type of damages, compensation or benefit payable by or for the Contractor Provider or any subcontractor under Workers' Compensation Acts, disability benefit acts, or other employee benefit acts.

**13.6** No provisions of Section 13 herein shall be construed to negate, abridge, or otherwise reduce any other right of indemnity that the City may have as to any party or person described therein.

**13.7 Insurance**

**13.7.1 General Liability and Automobile Liability.** The Contractor Provider shall purchase and maintain in force during the term of the Contract, at its own cost and expense, to protect the Contractor Provider, the City, and the members (including, without limitation, all members of the governing City's Council and the citizens' advisory committees of each), officers agents, and employees of each, from and against all liabilities arising out of or in connection with the Contractor Provider's performance of the Contract work:

- (1) **Commercial general liability insurance** with coverage of not less than ONE MILLION DOLLARS (\$1,000,000.00) combined single limit per occurrence, and with contractual liability coverage for Contractor Provider's covenants to and indemnification of the City under the Contract, and --
- (2) **Automobile liability insurance** with policy limits of not less than ONE MILLION DOLLARS (\$1,000,000.00) combined single limit per accident or occurrence covering each motor vehicle operated on City property.

**13.7.1.1 Self-Insured Retention.** Contractor Provider's commercial general liability insurance policies shall not be subject to a self-insured retention exceeding \$10,000, if the value of the Contract is less than \$1,000,000, and not be subject to a self-insured retention exceeding \$100,000, if the Contract is \$1,000,000 or more, unless approved by the City Manager. Contractor Provider's automobile liability insurance policies shall not be subject to a self-insured retention exceeding \$10,000 unless approved by the City Manager.

**13.7.1.2 Additional Insured Endorsement.** Contractor Provider agrees and shall cause the City, their members (including, without limitation, members of the City's Council and members of the citizens' advisory committees of each), officers, employees, and agents to be named as

**EXHIBIT A**  
**GENERAL CONDITIONS**

additional insured under such policy or policies of commercial general and automobile liability insurance.

**13.7.1.3** **Workers' Compensation and Employer's Liability.** If the Contractor Provider has any employee working on City property, Contractor Provider shall procure and maintain in force during the term of the Contract (i) workers' compensation insurance, and (ii) employer's liability insurance. The policy limits of the Contractor Provider's employer's liability insurance shall not be less than \$100,000 for "each employee." If the Contractor Provider is self-insured, the Contractor Provider shall provide proof of self-insurance and authorization to self-insurance as required by applicable state laws and regulations.

**13.7.3** **Professional Liability Insurance.** The Contractor Provider shall purchase and maintain in force during the term of the Contract, Professional Liability insurance which will pay for damages arising out of errors or omissions in the rendering, or failure to render professional Contractor services under the Contract in the amount of at least ONE MILLION DOLLARS (\$1,000,000.00) per claim. Such insurance must contain nose and tail coverage to include work performed by the Contractor Provider from the project's inception date and until such time as the Statute of Limitations has run for the work done on the project.

**13.7.4** Health Insurance. **Not applicable.**

**13.7.5** Garage Liability Insurance. **Not applicable.**

**13.7.6** Garage Keeper's Legal Liability Insurance. **Not applicable.**

**13.7.7** Crime Coverage. **Not applicable.**

**13.7.8** Pollution Liability Insurance. **Not applicable.**

**13.7.9** **Deductibles.** The Contractor Provider's policies of insurance required by this Section 13.7 may require the Contractor Provider's payment of a deductible, provided the Contractor Provider's insurer is required to pay claims from the first dollar at 110% of the claim value without any requirement that the Contractor Provider pays the deductible prior to its insurer's payment of the claim.

**13.7.10** **Other Insurance Requirements.** All insurance policies required by this Section 13.7 shall be, if they are primary insurance with respect to any other valid insurance the City may possess, any other insurance the City does possess shall be considered excess insurance only. All such insurance shall be carried out with a company or companies which meet the requirements of Section 14.2 of these General Conditions and said policies shall be in a form satisfactory to the City. A properly completed and executed Certificate of Insurance on a form provided or approved by the City (such as a current ACOROAD certificate of insurance)



**EXHIBIT A**  
**GENERAL CONDITIONS**

evidencing the insurance coverage required by this Section shall be furnished to the City by the Contractor Provider and shall provide the City with at least thirty (30) days' prior written notice of any adverse material change in the Contractor Provider's required insurance coverage except that ten (10) days' notice of cancellation for non-payment is required. For purposes of this Section 13.7.10, and "adverse material change" shall mean any reduction in the limits of the insurer's liability, any reduction, non-renewal or cancellation of any insurance coverage, or any increase in the Contractor Provider's self-insured retention. Prior to the expiration of any such policy, the Contractor Provider shall file with the City a certificate of insurance showing that such insurance coverage has been renewed. If the insurance coverage is canceled or reduced, the Contractor Provider shall, within five (5) days after such cancellation or reduction in coverage, file with the City a certificate showing that the required insurance has been reinstated or provided through another insurance company or companies approved by the City. If the Contractor Provider fails to obtain or have such insurance reinstated, the City may, if it so elects, and without waiving any other remedy it may have against the Contractor Provider, immediately terminate this Contract upon written notice to the Contractor Provider. The City Manager shall have the right to alter the monetary limits or coverage herein specified from time to time during the term of this Contract, and the Contractor Provider shall comply with all reasonable requests of the City Manager with respect thereto.

**14. LIABILITY INSURANCE**

- 14.1** The Contractor Provider shall be required to provide the bonds as dictated in the Procurement Documents in **Exhibit D**.
- 14.2** Liability Insurance Companies furnishing insurance coverage required by these General Conditions shall (a) be approved to issue insurance policies in the State of Georgia, and (b) must have no less than a "B+" Financial Rating and a Financial Size Category of "Class VI" or higher according to the most current edition of A.M. Best's Insurance Reports. If the liability insurer is rated by A.M. Best's Insurance Reports at an "A- Financial Rating and a Financial Size Category of "Class VIII" or higher than, the City Manager may waive the requirement for the insurer to be approved by the State of Georgia.

**15. CONTRACT ADJUSTMENTS**

- 15.1** Notwithstanding any provision herein to the contrary, the City reserves the right to modify at any time the nature, method, scope, frequency, or timing of the Contractor Provider's obligations under this Contract (Contract Adjustments) in whatever manner it determines to be reasonably necessary for the proper completion of the Contractor Provider's work hereunder. Both parties agree that, should any Contract Adjustments be made, the Contractor Provider's compensation will be adjusted accordingly, in such amount or amounts as will be

**EXHIBIT A**  
**GENERAL CONDITIONS**

mutually agreed to by means of good-faith negotiation by the City and Contractor Provider and, to the extent possible, by reference to any unit costs already established in the Proposal. Without exception, all deletions, or additions to the scope of work will be set forth in a written Amendment to this Contract.

**15.2** Notwithstanding the foregoing, the City shall have the right to terminate this Contract herein should the Contractor Provider and the City fail to reach agreement on the adjusted compensation within thirty (30) days after the date of the Contract Adjustment.

**15.3** Notwithstanding the foregoing, there shall be no upward adjustment of the compensation on account of any Contract Adjustment made necessary or appropriate because of the mismanagement, improper act, or other failure of the Contractor Provider, its employees, agents, or its subcontractors to properly perform its obligations and functions under this Contract.

**16. SUBCONTRACTORS**

**16.1** The Contractor Provider shall perform all its obligations and functions under this Contract utilizing its own employees, or by a duly qualified subcontractor which is approved in advance by the City. Such subcontractor which is an affiliate, parent, or subsidiary company; or had principal owners, relative, management, or employees common to the Contractor Provider; or any other party that can significantly influence the management or daily business operations of the subcontractor must be disclosed in writing to the City Manager. The goods and Services provided by subcontractors, which are reimbursed by the City, must be bona fide arm's-length transactions. In the event a subcontractor is employed, the Contractor Provider shall continuously monitor the subcontractor's performance, shall remain fully responsible to ensure that the subcontractor performs as required, and itself performs or remedies any obligations or functions which the subcontractor fails to perform properly. Nothing contained herein shall be construed to prevent the Contractor Provider from using the Services of a common carrier for delivering goods to the City. The city approves the sub-contractor Providers listed in the Statement of Qualifications.

**16.2** This Contract shall be referred to and incorporated within any contractual arrangement between the Contractor Provider and a subcontractor and, in such contractual arrangement; the subcontractor shall give its express written consent to the provisions of this Section 16. To the extent feasible, the provisions of this Contract shall apply to any such subcontractor in the same manner as they apply to the Contractor Provider; however, such application shall neither make any subcontractor a party to this Contract nor make such subcontractor a third-party beneficiary hereof.

**16.3** If the Contractor Provider employs a subcontractor, the City may require that copies of invoices for all work (including invoices submitted to the Contractor Provider for work performed by a subcontractor) be submitted to the City by the Contractor Provider and the City shall pay all compensation to the Contractor Provider. It shall be the sole responsibility of the Contractor Provider to deal with a subcontractor concerning the collection and submission of invoices and the

**EXHIBIT A**  
**GENERAL CONDITIONS**

payment of compensation. In no event shall the City have any obligation or liability hereunder to any subcontractor, including any obligations of payment.

**17. DEFAULT AND TERMINATION**

**17.1** In the event that:

**17.1.1** The Contractor Provider shall fail to keep, perform, or observe any of the promises, covenants, or agreements outlined in this Contract (if notice of the first failure shall have been given to the Contractor Provider, but whether the Contractor Provider shall have remedied any such failure); or

**17.1.2** The Contractor Provider shall fail to keep, perform, or observe any promise, covenant, or agreement outlined in this Contract, and such failure shall continue for more than five (5) days after delivery to the Contractor Provider of a written notice of such breach or default; or

**17.1.3** The Contractor Provider's occupational or business license shall terminate, or the Contractor Provider shall fail to provide the City with any bond, letter of credit, or evidence of insurance as required by the Contract Documents, for any reason; or

**17.1.4** The Contractor Provider fails, for any reason, to provide the City with an acceptable renewal or replacement bond or letter of credit within the time specified by a provision for this Contract; or

**17.1.5** The Contractor Provider shall become insolvent, or shall take the benefit of any present or future insolvency statute, or shall make a general assignment for the benefit of the creditor, or file a voluntary petition in bankruptcy or a petition or answer seeking an arrangement for its reorganization, or the readjustment of its indebtedness under the Federal Bankruptcy laws, or any other law or statute of the United States or any State thereof, or shall consent to the appointment of a receiver, trustee or liquidator of all or substantially all of its property; or

**17.1.6** The Contractor Provider shall have a petition under any part of the Federal Bankruptcy laws, or an action under any present or future insolvency laws or statute filed against it, which petition is not dismissed within thirty (30) days after the filing thereof; or

**17.1.7** There is an assignment by the Contractor Provider of this Contract or any of the Contractor Provider's rights and obligations hereunder for which the City has not consented in writing; or

**17.1.8** The Contractor Provider shall default on any other agreement entered by and between the Contractor Provider and the City, then, in its discretion, the City shall have the right to terminate this Contract for default, which termination shall be effective upon delivery of written notice of such termination to the Contractor Provider. If the City terminates this Contract for default, or the Contractor Provider abandons or wrongfully terminates the Contract, the Contractor Provider shall be paid for compensation earned to the date of termination or abandonment (but the

**EXHIBIT A**  
**GENERAL CONDITIONS**

City shall have the right to reduce by off-set any amounts owed to the Contractor Provider hereunder or under any other Contract or obligation by the amount of the City's damages and any amounts owed by the Contractor Provider to the City), but the Contractor Provider shall not be compensated for any profits earned or claimed after the receipt of the City's notice of termination by default or after abandonment or wrongful termination. The City's election to terminate or not to terminate this Contract in part or whole for the Contractor Provider's default shall in no way be construed to limit the City's right to pursue and exercise any other right or remedy available to it pursuant to the terms of the Contract or otherwise provided by law or equity.

**17.2** Notwithstanding anything else herein contained, the City may terminate this Contract in whole or in part, at any time, for its convenience by giving the Contractor Provider thirty (30) days' written notice. In that event, the Contractor Provider proceeds to complete any part of the work, as directed by the City and shall settle all its claims and obligations under the Contract, as directed by the City. The Contractor Provider shall be compensated by the City in accordance with the provisions hereof, including Section 2 of these General Conditions, provided; however, in no event shall the Contractor Provider be entitled to compensation for work not performed or for anticipatory profits. The contractor Provider shall justify its claims, as requested by the City, with accurate records and data.

**17.3** **Bankruptcy and Liquidation** – In the event the Contractor Provider (1) makes an assignment for the benefit of creditors, or petition or apply to any tribunal for the appointment of a custodian, receiver, or trustee for all or a substantial part of its assets; (2) commences any proceeding under any bankruptcy, reorganization, arrangement, readjustment of debt, dissolution, or liquidation law or statute of any jurisdiction whether now or hereafter in effect; (3) has had any such petition or application filed, or any such proceeding commenced against it in which an order for relief is entered or an adjudication or appointment is made, and which remains undismissed for a period of sixty(60) days or more; (4) takes any corporate action indicating its consent to approval of, or acquiescence in any such petition, application, proceeding, or order for relief or the appointment of a custodian, receiver, or trustee for all or substantial part of its assets; or (5) permits any such custodianship, receivership, or trusteeship to continue undischarged for a period of sixty (60) days or more causing the Contractor Provider or any third party, including, without limitation, a trustee in bankruptcy, to be empowered under state or federal law to reject this Contract or any agreement supplementary hereto, the City shall have the following rights:

- (i) In the event of a rejection of this Contract or any agreement supplementary hereto, the City shall be permitted to retain and use any back-up or archival copies of the software licensed hereunder under this Agreement for the purpose of enabling it to mitigate damages caused to the City because of the rejection of this Contract. The City shall exert

**EXHIBIT A**  
**GENERAL CONDITIONS**

reasonable efforts to mitigate such damage by use of such back-up or archival copies.

- (ii) In the event of rejection of this Contract or any agreement supplementary hereto, the City may elect to retain its rights under this Contract or any agreement supplementary hereto as provided in Section 365(n) of the Bankruptcy Code. Upon written request of the City to, as applicable, the Contractor Provider, or the bankruptcy trustee or receiver. The Contractor Provider or such bankruptcy trustee or receiver shall not interfere with the rights of the City as licensee as provided in this Contract or in any agreement supplementary hereto to obtain the Source Material(s) from the bankruptcy trustee and shall, if requested, cause a copy of such Source Material(s) to be available to the City.
- (iii) In the event of rejection of this Contract or any agreement supplementary hereto, the City may elect to retain its rights under this Contract or any agreement supplementary hereto as provided in section 365(n) of the Bankruptcy Code without prejudice to any of its rights of setoff with respect to this Contract under the Bankruptcy Code or applicable non-bankruptcy law; or in the event of a rejection of this Contract or any agreement supplementary hereto, the City may retain its rights under this Contract or any agreement supplementary hereto as provided in section 365(n) of the Bankruptcy Code without prejudice to any of its right under section 503(b) of the Bankruptcy Code.

**18. THE CITY'S AUTHORIZED REPRESENTATIVE**

During the term of this Contract, the City Manager, or their designee, may from time to time designate an individual to serve as the City's Authorized Representative (CAR) and an Assistant CAR designated to serve in that capacity in the absence of the CAR, who shall have such authority to act on the City's behalf as the City Manager may from time to time delegate to such person, but in no event shall the CAR have authority to modify or terminate this Contract or make final decisions concerning amendments, time extensions, assignments, cost or payment adjustments or payment disputes.

**19. ASSIGNMENT**

Neither this Contract nor any of the Contractor Provider's rights or obligations hereunder may be assigned by the Contractor Provider without the City's prior written consent, which consent may be granted or withheld at the City's sole discretion. Any transfer of this Contract by merger, consolidation, or liquidation (unless the stock of the Contractor Provider is traded on a national stock exchange or, in a generally recognized over-the-counter securities market,) any change in ownership of a power to vote most of the outstanding voting stock or ownership interests of the Contractor Provider shall constitute an assignment of this Contract for this Section. In the event the Contractor Provider assigns subcontracts or attempts to assign or subcontract any right or obligation arising under this Contract without the City's prior written consent, the City shall be entitled to terminate this Contract according to the provisions of Section 17 hereof.

**EXHIBIT A**  
**GENERAL CONDITIONS**

**20. NOTICES**

**20.1** Unless otherwise stated herein, all notices or other writings that the City is required or permitted to give to the Contractor Provider may be hand-delivered, mailed via U.S. Certified Mail, or sent next-day delivery by a nationally recognized overnight delivery contractor to the Contractor Provider’s address outlined in the Proposal. Any such notice shall be deemed to have been delivered upon actual delivery, or one (1) day following submission to a nationally recognized overnight delivery contractor for next-day delivery to the Contractor Provider, or three (3) days following submission to the Contractor Provider by U.S. Certified Mail.

**20.2** Unless otherwise stated herein, all notices or other writings that the Contractor Provider is required or permitted to give to the City may be hand-delivered to the City Manager, mailed via U.S. Certified Mail, or sent next-day delivery by a nationally recognized overnight delivery contractor for next day delivery to the City or three (3) days following submission to the City by U.S. Certified Mail. Any such notice shall be sent to:

City of Brookhaven, GA  
ATTN: City Manager  
4362 Peachtree Road NE  
Brookhaven, GA 30319

Contractor Provider **(Provide Mailing Address)**

\_\_\_\_\_  
\_\_\_\_\_  
\_\_\_\_\_

**20.3** Either party may change its notice address by written notice to the other given as provided in this section.

**21. NONDISCRIMINATION**

**21.1** During the performance of this Contract, the Contractor Provider, for itself, its assignees, and successors in interest agree as follows:

**21.1.1** **Compliance with Regulations.** The Contractor Provider shall comply with the Law and Regulations as they may be amended from time to time (hereafter referred to as the “Regulations”), which are herein incorporated by reference and made a part of this Contract.

## EXHIBIT A

### GENERAL CONDITIONS

**21.1.2** **Nondiscrimination.** The Contractor Provider, regarding the work performed by it during the Contract, shall not discriminate on the grounds of race, color, or national origin in the selection and retention of any subcontractor, including procurement of materials and leases of equipment. The Contractor Provider shall not participate, either directly or indirectly, in the discrimination prohibited by the Regulations.

**21.1.3** **Solicitations for Subcontracts, Including Procurement of Materials and Equipment.** In all solicitations, either by competitive proposing or negotiation made by the Contractor Provider for work to be performed under a subcontract, including procurement of materials or leases of equipment, each potential subcontractor or supplier shall be notified by the Contractor Provider of the Contractor Provider's obligations under this Contract and the Regulation relative to nondiscrimination on the grounds of race, color, or national origin.

**21.1.4** **Information and Reports.** The Contractor Provider shall provide all information and reports required by the Regulations or directives issued pursuant thereto and shall permit access to its books, records, accounts, other sources or information, and its facilities as may be determined by the City to be pertinent to ascertain compliance with such regulations, orders, and instructions, the Contractor Provider shall so certify to the City, as appropriate, and shall set forth what efforts it has made to obtain the information.

**21.1.5** **Sanctions for Noncompliance.** In the event of the Contractor Provider's noncompliance with the nondiscrimination provisions of this Contract, the City shall impose such Contract Sanctions as it may determine to be appropriate, including but not limited to:

- (i) Withholding of payments to the Contractor Provider under the Contract until the Contractor Provider complies, and/or
- (ii) Cancellation, termination, or suspension of the Contract, in whole or in part.

**21.1.6** **Incorporation of Provisions,** The Contractor Provider shall include the provisions of subsections 21.1.1 through 21.1.5 in every subcontract, including procurement of materials and leases of equipment, unless exempt by the Regulations or directives issued pursuant thereto. The Contractor Provider shall take such action concerning any subcontractor procurement as the City may direct as a means of enforcing such provisions including sanctions for noncompliance. Provided; however, that in the

## EXHIBIT A

### GENERAL CONDITIONS

event the Contractor Provider becomes involved in, or is threatened with, litigation with a subcontractor or supplier as a result of such direction, the Contractor Provider may request the City to enter into such litigation to protect the interest of the City and, in addition, the Contractor Provider may request the interest of the City and, in addition, the Contractor Provider may request the United States to enter into such litigation to protect the interests of the United States.

**21.2** The Contractor Provider assures the City that it will comply with the pertinent statutes, Executive Orders, and such rules as are promulgated to assure that no person shall, on the grounds of race, creed, color, national origin, sex, age, marital status, or handicap, be excluded from participating in any activity conducted with or benefiting from Federal assistance. This provision shall bind the Contractor Provider from the period beginning with the initial solicitation through the completion of the Contract.

### **22. COPYING DOCUMENTS**

The Contractor Provider hereby grants the City and its agent's permission to copy and distribute all materials and documents contained in, comprising of, or which are otherwise submitted to the City with or in connection with the Contractor Provider's proposal, or which are contained in the Contract Documents (the "Submittals"). The permission granted by the Contractor Provider shall be on behalf of the Contractor Provider and all other parties who claim any rights to any of the materials or documents comprising the Submittals. Such permission specifically authorizes the City and its agents to make and distribute such copies of the Submittals or portions thereof as may be deemed necessary or appropriate by the City for its internal purposes or for responding to requests for copies from any member of the public regardless of whether the request is specifically characterized as public records request according to Georgia Code. This provision shall survive the expiration or termination of the Contract.

### **23. GENERAL PROVISIONS**

**23.1** The Contract Documents consist of the Contract, the Proposal Forms, the Instructions to Proposers, Request for Qualifications, all Addendum or Addenda issued before the execution of this Contract, these General Conditions, and Specifications. Together, these documents comprise the Contract and all the documents are fully a part of the Contract as if attached to the Contract or repeated herein. Precedence of the Contract Documents shall be as follows: (i) Addendum or Addenda to the Contract Documents, (ii) the Contract, (iii) the General Conditions, (iv) the Scope of Work in Exhibit B, (v) the Invitation to Bid, and (vi) the Bid Form.



**EXHIBIT A**  
**GENERAL CONDITIONS**

- 23.2** This Contract represents the entire agreement between the parties regarding the subject matter hereof and supersedes all prior agreements and understandings between such parties relating to such subject matter, and there are no contemporaneous written or oral agreements, terms or representation made by any party other than those contained herein. No verbal or written representations shall be relied upon outside the Contract terms and amendments. Without exception, all deletions, or additions to the scope of work will be outlined in a written amendment to this Contract. No amendment, modification, or waiver of this Contract, or any part thereof, shall be valid or effective unless in writing signed by the party or parties sought to be bound or charged therewith; and no waiver of any breach or condition of this Contract shall be deemed to be a waiver of any other subsequent breach or condition, whether of a like or different nature.
- 23.3** The Contractor Provider shall, during the term of this Contract, repair any damage caused to real or personal property of the City and/or its tenants, wherever situated, caused by the intentional, reckless, or negligent acts or omissions of the Contractor Provider, its officers, agents, or employees, and any subcontractors and their officers, agents, or employees, or, at the option of the City, the Contractor Provider shall reimburse the City for the cost of repairs thereto and replacement thereof accomplished by or on behalf of the City.
- 23.4** The Contractor Provider warrants to the City that no work performed, or materials purchased according to the Contract, whether by, from, or through the Contractor Provider or a subcontractor, shall cause any claim, lien, or encumbrance to be made against any property of the City, and the Contractor Provider shall indemnify and save the City harmless from and against any losses, damages, and costs, including attorneys' fees, with respect thereto. If any such claim, lien, or encumbrance is to be filed, the Contractor Provider shall, within thirty (30) days after notice of the filing thereof, cause the same to be discharged of record by payment, deposit, bond, an order of a court of competent jurisdiction or otherwise. This provision shall survive the expiration or termination of the Contract.
- 23.5** The language of this Contract shall be construed according to its fair meaning, and not strictly for or against either the City or the Contractor Provider. This Contract shall be deemed to be made, construed, and performed according to the laws of the State of Georgia. Any suit or proceeding initiated to interpret or enforce any provision of this Contract or any matter in connection therewith shall be brought exclusively in a court of competent jurisdiction in DeKalb County, Georgia, and the Contractor Provider waives any venue objection, including, but not limited to, any objection that a suit has been brought in an inconvenient forum. The Contractor Provider agrees to submit to the jurisdiction of the Georgia courts and irrevocably agrees to acknowledge service of process when requested by the City.
- 23.6** The section headings herein are for the convenience of the City and the Contractor Provider and are not to be used to construe the intent of this Contract or any part thereof or to modify, amplify, or aid in the interpretation or construction of any of the provisions hereof.

**EXHIBIT A**  
**GENERAL CONDITIONS**

- 23.7** The use of any gender herein shall include all genders and the use of any number shall be construed as the singular or the plural, all as the context may require.
- 23.8** The delay or failure of the City at any time to insist upon the performance of any of the terms, conditions, and covenants herein shall not be deemed a waiver of that breach or any subsequent breach or default in the terms, conditions, or covenants of this Contract. The Contractor Provider shall not be relieved of any obligation hereunder on account of its failure to perform because of any strike, lockout, or other labor disturbance.
- 23.9** If the City shall, without any fault, be made a party to any litigation commenced between the Contractor Provider and a third party arising out of the Contractor Provider's operations and activities at the premises, then the Contractor Provider shall pay all costs, and reasonable attorney's fees incurred by or imposed upon the City in connection with such litigation for all trial and appellate proceedings. The City shall give prompt notice to the Contractor Provider of any claim or suit instituted against it by any third party. The provisions of this Section supplement and are not intended to be in place of the indemnification provisions of Section 5 hereof. The provisions of this Section shall survive the acceptance of the services and payment, therefore, and the expiration or earlier termination of this Contract.
- 23.10** The City shall have the right to recover from the Contractor Provider all the City's costs and expenses incurred in enforcing the provisions of this Contract including, but not limited to:
- (i)** The cost of administrative investigation and enforcement (Including, without limitation, audit fees and costs, attorneys' fees) and:
  - (ii)** The cost of any trial, appellate, or bankruptcy proceeding (including, without limitation, investigation costs, audit fees and costs, attorney's fees, court costs, paralegal fees, and expert witness fees). This provision shall survive the expiration or termination of the Contract.
- 23.11** The Contractor Provider shall not, during the term of the Contract knowingly hire or employ (on either a full-time or part-time basis) any employee of the City.
- 23.12** The Contractor Provider shall be required, during the term of the Contract and at no additional cost to the City, to take such reasonable security precautions concerning its operations at City Hall as the City in its discretion may from time to time prescribe. The Contractor Provider shall comply with all regulations, rules, and policies of any governmental authority, including the City, relating to security issues.
- 23.13** The City may, but shall not be obligated to cure, at any time, upon five (5) days written notice to the Contractor Provider (provided, however, that in any emergency the City shall be required to give only such notice as is reasonable in light of all the circumstances), any default by the Contractor Provider under this Contract; whenever the City so cures a default by the Contractor Provider, all costs and expenses incurred by the City in curing the default, including, but

**EXHIBIT A**  
**GENERAL CONDITIONS**

not limited to, reasonable attorneys' fees, shall be paid by the Contractor Provider to the City on demand.

**23.14** The City shall, in its discretion, be entitled to deduct from the compensation to which the Contractor Provider is otherwise entitled hereunder, an amount equal to any liabilities of the Contractor Provider to the City which is then outstanding. If additional work beyond the scope of this Contract is requested by the City Manager and it results in any extra charges to the City, the Contractor Provider shall so advise the City in writing of the amount of the extra charges. The City is not required to pay any extra charges for additional work unless such work and the charges, therefore, have been approved in advance and have been confirmed in writing within twenty-four (24) hours by the City Manager, in their exclusive discretion.

**23.15** The Contractor Provider is an Independent Contractor Provider, and nothing contained herein shall be construed as making the Contractor Provider an employee, agent, partner, or legal representative of the City for any purpose whatsoever. The Contractor Provider acknowledges that it does not have any authority to incur any obligations or responsibilities on behalf of the City and agrees not to hold itself out as having any such authority. Nothing contained in this Contract shall be construed to create a joint employer relationship between the City and the Contractor Provider concerning any employee of the Contractor Provider or of its subcontractors.

**23.16** The Contractor Provider and its subcontractors, if any, shall maintain complete and accurate books and records under generally accepted accounting principles, consistently applied, and shall be in a form reasonably acceptable to the City Manager or designee. The Contractor Provider and its subcontractors shall account for all expenses of any nature related to transactions in connection with the Contract in a manner that segregates, in detail, those transactions from other transactions of the Contractor Provider and subcontractors, and which support the amounts reported and/or invoiced to the City. At a minimum, the Contractor Provider's and subcontractor's accounting for such expenses and transactions shall include such records in the form of electronic media compatible with or convertible to a format compatible with computers utilized by the City at its offices; a computer run hard copy; or legible microfilm or microfiche, together with access to the applicable reader. All such books and records and computerized accounting systems shall upon reasonable notice from the City, the U.S. Office of Housing and Community Development, the Comptroller General of the United States, or other authorized governmental agencies be made available in Brookhaven, for inspection, examination, audit and copying by the City through and by its duly authorized representatives at any time for up to five (5) years after the year to which books and records pertain. Such inspection, examination, or audit may include, but is not limited to, a review of the general input, processing, and output controls of information systems, using read-only access, for all computerized applications used to record financial transactions and information. The Contractor Provider and subcontractor shall freely lend their assistance promptly in making such inspection, examination, audit, or

**EXHIBIT A**  
**GENERAL CONDITIONS**

copying and, if such records are maintained in electronic and other machine-readable formats, shall provide the City and/or its representative such assistance as may be required to allow complete access to such records. The City Manager may require the Contractor Provider and subcontractors to provide other records the City Manager, in their sole discretion, deems necessary to enable the City to perform an accurate inspection, examination, or audit of expenses incurred in and transactions related to the performance of this Contract. Such records shall be provided within thirty (30) days or requested thereof. If expenses incurred or reimbursed are found by such inspection, examination, or audit to have been overpaid, the Contractor Provider and its subcontractors agree that such amounts shall be payable to the City. If, before the expiration of the above-stated four (4) year record retention period, an audit or investigation is commenced by the City, or any claim is made or litigation commenced relating to this Contract by the City, the Contractor Provider, or third party, the shall continue to maintain all such records, and the City shall continue to have the right to inspect such records in the manner stated above until the inspection, examination, audit, claim, or litigation is finally resolved (including the determination of any appeals or the expiration of time for an appeal). This provision shall survive the expiration or earlier termination of this Contract. In the event of any conflict between any provision of this Contract and generally accepted accounting principles or generally accepted auditing standards, the provisions of this Contract shall control even where this Contract references such provisions or standards. Without limitation, the Contractor Provider and subcontractors shall maintain all records required under this Contract to the full extent required hereunder, even if some or all such records would not be required under such generally accepted accounting principles or auditing standards. If, as a result of an inspection, examination or audit, it is established that amounts are due from the Contractor Provider to the City, the Contractor Provider shall forthwith, upon written demand from the City, pay the City such amount, together with interest on the amount due at the rate of twelve (12%) percent per annum, or if less, the maximum rate of interest allowed by law, from the date such additional amounts were overpaid by the City. Further, if such inspection, examination, or audit establishes that the Contractor Provider has overbilled such amounts for any Contract period by two (2%) percent or more, then the entire expense of such inspection, examination, or audit shall be paid by the Contractor Provider.

- 23.17** The Contractor Provider and subcontractors shall prepare and provide the City with all detailed reports as required under the Contract on a timely basis. The City reserves the right to modify the reporting procedures or the form and content of any report as it deems necessary.
- 23.18** There are no third-party beneficiaries to this Contract, and nothing contained herein shall be construed to create such.
- 23.19** Time is of the essence for the performance of each of the Contractor Provider's obligations under this Contract.

**EXHIBIT A**  
**GENERAL CONDITIONS**

- 23.20** In computing any period established under this Contract, except as otherwise specified herein the word “days” when referring to a period is ten (10) days or less means business days, and when referring to a period that is more than ten (10) days means calendar days. The day of the event, from which the designated period begins to run shall not be included. A business day is any day other than Saturday, Sunday, or Federal, State of Georgia, or City holidays.
- 23.21** The Contractor Provider agrees to perform all acts and execute all supplementary instruments or documents which may be reasonably necessary to carry out or complete the transaction(s) contemplated by this Contract.
- 23.22** The City reserves the right to further develop, improve, repair, and alter the facilities and all roadways, and parking areas, as it may reasonably see fit, free from any liability to the Contractor Provider for loss of business or damages of any nature whatsoever to the Contractor Provider occasioned during the making of such improvements, repairs, alterations and additions, including, but not limited to, any damages resulting from negligence of the City or its employees, agents or services.
- 23.24** The Contractor Provider and the City hereby mutually waive any claim against each other and their respective members, officials, officers, agents, and employees for damages (including damages for loss of anticipated profits) caused by any suit or proceedings brought by either of them or by any third party directly or indirectly attacking the validity of this Contract or any part thereof, or any addendum or amendment hereto, or how this Contract was solicited, awarded or negotiated, or arising out of any judgment or award in any suit or proceeding to declare this Contract, or any addendum/addenda or amendment hereto, null, void or voidable or delaying the same, or any part thereof, from being carried out.
- 23.24** At the option of the Contractor Provider, the products and/or services provided under the Contract resulting from this solicitation may be provided to other governmental agencies, including the State of Georgia, its agencies, political subdivisions, counties, and cities under the same terms and conditions, including price, as such products and/or services are provided under this Contract. Each governmental agency allowed by the Contractor Provider to purchase products and services in connection with this Contract shall do so independently of the City or any other governmental entity. Each agency shall be responsible for its purchases and be liable only for goods and services ordered, received, and accepted by it. The City shall have no liability to the Contractor Provider or any governmental agency resulting from the purchase by that agency of products and services from the Contractor Provider in connection with this Contract.

**EXHIBIT A**  
**GENERAL CONDITIONS**

**24. GRATUITIES, REBATES, OR KICKBACKS.**

**24.1**      **GRATUITIES.** It shall be unethical for any person to offer, give, or agree to give any employee or official of the City or for any employee or official of the City to solicit, demand, accept from another person, a gratuity, rebate, loan, offer of employment or other services property of value in connection with any decision, approval, disapproval, recommendation, or preparation of any part of a program requirement or a purchase request including the content of any specification or procurement standard, rendering of advice, investigation, auditing or in any other advisory capacity in any particular matter, on any program requirement or a contract or subcontract, or to any solicitation or proposal therefore in any manner inconsistent with the State of Georgia's Department of Administrative Services Gratuity Policy. Rebates normally or routinely offered to customers in the ordinary course of business for the purchase of goods and services are acceptable and are the property of the City.

**24.2**      **KICKBACKS AND REBATES.** It shall be unethical for any payment, gratuity, or offer of employment to be made by or on behalf of a subcontractor to this Contract to the prime contract or higher tie subcontractor, or any person associated therewith, as an inducement for a subcontractor or order.

**\*\*\*\*\* END OF GENERAL CONDITIONS\*\*\***

**EXHIBIT B**  
**SPECIFICATIONS AND SCOPE OF WORK**

**Contract Duration:** **Ninety (90) calendar days.** The Department of Housing & Urban Development (HUD) is providing the source funding for this project within a specified and limited time frame. For the City to submit reimbursable claims to HUD for completed work, the Contractor Provider shall present all invoices to the City as soon as possible for all completed work, until the project closes out.

**Project Description:**

There are two specific Tasks related to this project.

**Task 1:** Calls for the removal and replacement of one ramp, one commercial 25-ft driveway entrance sidewalk, and 175 LF of 5-ft sidewalk utilizing a “sidewalk turn down wall detail” and the installation of a handrail on the east side of Briarwood Road from The Hillcrest Apartments (3446 Buford Hwy) to Buford Hwy. Task one specifications and details are provided in the contract documents as **Exhibit N.**

**Task 2:** Calls for removing and replacing sidewalk ramps and sidewalk sections other than those specified as Task 1. Task 2 specifications and details are found under the heading **Project Scope.** **The bid sheet for Tasks 1 & 2 is in Section K of this document.**

The Contractor Provider shall provide the necessary machinery, tools, apparatus, or other means, and all materials and labor specified in the Contract Documents or other means necessary to complete the installation or repair of ADA ramps identified within this contract. Unless otherwise directed, all work performed shall be per the Georgia Department of Transportation *Standard Road Specifications, Construction of Transportation Systems* (Current edition). All materials used in completing the work included in the Contract will be furnished from Georgia Department of Transportation certified suppliers only. There is no City-furnished equipment to be installed by the Contractor.

**Time and Liquidated Damages:**

The Contractor Provider shall not proceed to furnish such services, and the City shall not become obligated to pay for same until a written authorization to proceed (“Notice to Proceed”) has been issued to the Contractor Provider from the City. The Contractor shall commence the Work no later than ten (10) calendar days after the effective date of the Notice to Proceed and shall achieve Substantial Completion of the Work, as hereinafter defined, no later than **Ninety (90) calendar days**, per the Contract Documents. The number of calendar days from the date on which the Work is permitted to proceed, through the date set forth for Substantial Completion, shall constitute the Contract Time. The Work shall be carried on expeditiously, it being understood that this Contract shall not be extended or continued in force by the parties hereto as provided herein.

The Contractor shall pay the City the sum of \$500.00 per day for each calendar day of unexcused delay in achieving Substantial Completion beyond the date set forth herein for Substantial Completion of the Work. Any sums due and payable hereunder by the Contractor Provider shall be payable, not as a penalty, but as liquidated damages representing an estimate of delay damages likely to be sustained by the City, estimated at or before the time of executing this Contract. When the City reasonably believes that Substantial Completion will be inexcusably delayed, the City shall be entitled, but not required, to withhold from any amounts otherwise due the Contractor an

**EXHIBIT B**  
**SPECIFICATIONS AND SCOPE OF WORK**

amount then believed by the City to be adequate to recover liquidated damages applicable to such delays. When the Contractor Provider overcomes the delay in achieving Substantial Completion, or any part thereof, for which the City has withheld payment, the City shall promptly release to the Contractor Provider those funds withheld, but no longer applicable, as liquidated damages-

**Substantial Completion:**

Substantial Completion shall mean that stage in the progression of the Work when the Work is sufficiently complete per this Contract that the City can enjoy the beneficial use of the Work and may utilize the Work for its intended purpose. Partial use or occupancy of the Project shall not result in the Project being deemed Substantially Complete, and such partial use or occupancy shall not be evidence of Substantial Completion.

**Time is of the essence:**

All time limits outlined in the Contract Documents are of the essence of this Contract.

**Project Scope:**

**ADA Ramp Repair/Installation:** In 2019 and 2020 an evaluation was made of the sidewalk and multiuse path system within the City of Brookhaven to determine their overall condition and whether they conform to ADA standards at street and commercial driveway intersections. Based on this evaluation a list has been compiled by street listing ADA ramps that are either non-compliant or non-existent and ADA ramps that do not have the required warning mats.

**The project Scope shall include the following:**

**ADA Ramp Repair or Installation (Task 2).**

- In most cases, existing sidewalk ramps identified in this contract shall require full removal. In these cases, removal and replacement **shall include** all the identified ramps, required curb & gutter, and the **amount of the adjoining sidewalk** to achieve all ADA standard minimum/maximum slope requirements.
- Removal of existing sidewalk and curb/gutter where no ramp exists or removal of non-compliant ramp.
- Proper disposal of existing sidewalk, and curb of ramp material.

***Note: If the existing curb to be removed is granite curb and is of a size and condition to allow it to be reused by the City, the Contractor shall make every effort to salvage the curb and arrange for removed granite to be hauled to the City's Maintenance Yard.***

- Forming and pouring new ADA ramps per current ADA standards and specifications and the **Georgia Department of Transportation Special Detail A3, Concrete Sidewalk Details Curb Cut (Wheelchair)Ramps, as attached.** Ramps are to be poured at standard 5' width and tapered into the existing sidewalk if the existing sidewalk is narrower.
- **Backfill of soil around replacement sidewalk and ramp sections, and the replacement of displaced sod, is required under this Contract; however, when sod is not in season, the**



**EXHIBIT B**  
**SPECIFICATIONS AND SCOPE OF WORK**

Contractor Provider shall plant grass seed and provide straw cover to protect seeds and hold moisture to promote growth.

ADA Detectable Warning Devices

- Install ADA Detectable Warning Devices (Mats) on existing ADA ramps that do not have them.
- Detectable Warning Devices shall be installed per the Georgia Department of Transportation Special Detail A4, Detectable Warning Surface Truncated Dome Size, Spacing, and Alignment Requirements, as attached. Yellow Mats are hereby specified by the City of Brookhaven, GA.

Sidewalk Repair or Replace

- Sidewalk sections identified, but not connecting to a ramp are to be completely removed and replaced in kind (see item #2 in additional specifications, below).
- Sawcut where indicated at the identified location.
- Remove all sidewalk sections and haul offsite.
- Backfill and compact sidewalk sections to raise the sidewalk, matching existing sidewalk slopes/elevations.
- Excavate all sidewalk sections to lower the sidewalk, matching existing sidewalk slopes/elevations.
- Adjust valve boxes, hand holes, or other appurtenances up or down to meet new sidewalk elevation.
- Form and pour concrete to match the existing sidewalk.
- New sidewalks/sections shall result in a broom finish.
- Remove forms and backfill on both sides of the new sidewalk, backfilling with new soil and sod, as required.

Additional Specifications –

1. All concrete shall be 3,000 psi at 28 days unless GDOT specifications site a similar GDOT pay item of higher strength. Copies of all concrete delivery tickets shall be supplied to the City no later than the following business day.
2. All sidewalks and ramps are to be a minimum thickness of 4", **except within the limits of a street radius, where it shall be a minimum thickness of 8".**
3. All soil or Granular Aggregate Base compaction shall be 95% of the maximum density at the optimum moisture content.
4. All improvements shall conform to the Georgia Department of Transportation Standards and Specification; specifically, GDOT Special Detail Concrete Sidewalk Details Curb Cut (Wheelchair) Ramps, dated 3/12/2002, number A3, as attached.

**EXHIBIT B**  
**SPECIFICATIONS AND SCOPE OF WORK**

5. It is the Contractor Provider's responsibility to base the **price on each location specified on the bid sheet from the description given** for a new ADA ramp or repair of an existing ramp and sidewalk to ADA Standards. Bids shall be based on the total amount of materials removed and replaced. For example, ***the replacement cost of an existing ramp not only includes the cost of removing and replacing the ramp itself, but the total should be calculated based on removing and replacing the ramp, adjacent curbing, and the adjoining length of the sidewalk to meet the specified max/min slope of the new ramp.***
6. Pricing shall include costs for curb and gutter replacement/repair and any sidewalk section specified as "contiguous or adjoining" to the new/repared ramp according to the existing conditions of each location.
7. All concrete formworks shall allow for **strict compliance to all min/max slopes and approaches for all transitions and landing areas as shown on GDOT Special Detail A3, as attached.**
8. Grassing inside the construction area and the construction access areas are part of this Scope of Work, whether there is a specific pay item or not. Grassing in these areas shall be accomplished with Bermuda or Zoysia rolled sod, cut/harvested the day of or the day before installation. The Contractor Provider is responsible for the care of the sod, including frequent watering, in these areas until the sod has rooted.
9. The Contractor Provider shall be responsible for the restoration of any disturbance outside of these areas with Bermuda or Zoysia rolled sod, cut/harvested the day of, or the day before installation. Seeding and mulching will only be accepted if the property owner provides written permission to deviate from this requirement.
10. If grassing activities are not in season, ryegrass, or grassing as directed by the City's assigned project manager shall be utilized. Disturbed areas shall receive permanent stabilization if not sodded or stabilized as directed by this Contract or the City's assigned project manager. Once grassing is in season, the area will be prepared and reseeded or sodded with permanent grassing by the Contractor Provider.
11. Grassing outside of the construction area and construction access areas are outside of the Scope of Work contained in this Contract; however, the Contractor Provider shall be responsible for grassing these areas, at their own cost, if said damage is the result of negligence on the part of the Contractor Provider.
12. Erosion and Sediment Control BMPs are incidental to the Scope of Work and shall be installed per the GSWCC Manual for Erosion and Sediment Control in Georgia, latest edition (Green Book). Illicit discharges of sediments or other pollutants found in the Brookhaven stormwater network, resulting from the Work supplied by the Contractor Provider, shall be subject to a City of Brookhaven Code Violation Citation, fine, or both. Local, State of Georgia, and Federal Agencies may also document violations of this type and assess fines per established codes and laws.
13. Throughout the Work, the Contractor Provider shall submit a two-week work schedule **seven days** before the project starts and **email** schedule updates to the City's Project Manager every Monday morning for the next two weeks.

**EXHIBIT B**  
**SPECIFICATIONS AND SCOPE OF WORK**

14. **Traffic Control:** For this contract, **traffic control is mandatory.**
- Because Briarwood Road is a two-lane, two-way road, that exhibits heavy vehicular and pedestrian traffic, **police presence and flaggers are required for both tasks throughout this project.**
15. **Traffic control costs shall be presented as a single lump sum pay item on the bid sheet for each task.**
16. The contractor shall maintain through traffic via single-lane closure while allowing adequate access to driveways and side roads. No street shall be closed completely unless approved and directed by the Engineer. Post-mounted traffic control signs are not required.
17. A formal Traffic Control Plan shall be submitted to the City's Traffic Engineer on or before the preconstruction meeting, and before the commencement of work for review and approval.
18. Traffic control shall be performed per the City of Brookhaven and MUTCD standards including, but not limited to, signage removal and resetting of traffic signage.
19. Traffic control shall be provided by the contractor per GDOT's "shelf" Special Provision 150. Assistance from the City of Brookhaven police shall **not** be provided; however, if police presence is required to provide a work zone officer as needed, or as directed by the engineer, the Contractor Provider shall first coordinate with the City of Brookhaven Police Department, who have the **right of first refusal, and must be utilized, if available.**
20. For assistance during road improvement projects requiring an off-duty officer, contact **Lt. Patrick Bolls to plan and schedule the officer. His phone number is 770-369-0493His email is [patrick.bolls@brookhavenga.gov](mailto:patrick.bolls@brookhavenga.gov).**
21. Site preparation for ramps to include excavation and removal or import of material within the construction area, unless otherwise noted, and the compaction of the soil or any added Granular Aggregate Base material under the proposed ramp.
22. The Contractor Provider is responsible for coordinating underground utility locations before the start of the project and at any time throughout the project when any markings fade or become unreadable or unreliable. The Contractor Provider is responsible for coordinating the utility location work with any utility owner who may cite conflict with their work and claims and shall not be considered for additional compensation.
23. The Contractor Provider is responsible for coordinating with adjacent property owners regarding irrigation systems and landscaping. Damage to public/private irrigation systems or landscaping as a direct result of this Work shall be the responsibility of the Contractor Provider to remedy. Claims of this type, made against the Contractor Provider by private property owners, shall in no way be considered for additional compensation from the City.

**The City of Brookhaven does not warrant or guarantee the accuracy of any quantities depicted within this bid. It is the responsibility of the Contractor to verify all quantities in the field before submitting their bid.**

**EXHIBIT B**  
**SPECIFICATIONS AND SCOPE OF WORK**

**General Notes:**

1. Any existing appurtenances requiring removal to accommodate completion of the Work and, not specially called for in the Contract, shall be removed by the Contractor Provider. If present, the cost of removal of such appurtenances shall be calculated by the Contractor Provider and included as part of the line-item bid associated with that specific location.
2. This contract intends that the price per location includes all labor, materials, equipment, tools, transportation, and supplies as required and necessary to complete the work per the plans and specifications as directed and the terms of this contract. Additional unit costs shall not be allowed for clearing, grubbing, or grading activities unless otherwise specified.
3. The Contractor Provider shall coordinate with the property owners, pertinent to each location, to ensure adequate driveway access is provided to all properties.
4. The general descriptions of each work item are defined in the current edition of the Georgia Department of Transportation's Standards and Specifications, complete and accepted. Any conflicts occurring during the specified work related to the compensation of any work shall be decided based on the current edition of the GDOT Standards and specifications. Related claims made against the Contractor Provider by private property owners shall not be considered for additional compensation from the City.
5. Upon the completion of each project location, any excess items left over from the construction-related work shall be removed and disposed of properly by the Contractor. Costs related to the disposal of excess project materials shall be included as part of each project location and the aggregate bid total. No claims will be considered for extra compensation.
6. Under this scope, "Department," "Engineer", and "Resident Engineer" shall mean the "City of Brookhaven, Georgia, Public Works Director or City of Brookhaven, Georgia, Public Works Designee."
7. The Contractor Provider shall have all vehicles marked with their company name.
8. Working hours are expected to be Monday through Friday, 7:00 A.M. to 7:00 P.M. except where otherwise noted. Lane closures are limited to 9:00 A.M. to 4:00 P.M. No work is permitted during the weekend or City-observed holidays. The City of Brookhaven may, by written application of the Contract Provider, and the signed consent of the city manager, or their official representative, for work to be performed on Saturdays.
9. The Contractor Provider shall participate in one overall Contract Pre-Construction meeting at a location to be determined by the city's project manager shortly after the contract is awarded and attend other meetings as required. At its discretion, the City may require meetings between the Contractor Provider's project superintendent and the City's project Manager to be held once a week or additional meetings to ensure proper project execution.
10. Quantities of any of the pay items in the bid schedule of the contract that exceed the plan quantities will be installed on an as-needed basis, as directed by the City's project manager.
11. The Contractor shall provide video and photographs of each project location before and after the work. This media shall be provided electronically to the city's project manager in a format acceptable to the City.
12. The City of Brookhaven will not provide restroom facilities. The Contractor Provider shall furnish adequate on-site facilities for its employees throughout the project.

**EXHIBIT B**  
**SPECIFICATIONS AND SCOPE OF WORK**

13. The Contract Provider shall perform project housekeeping and clean-up daily. A 24-hour contact person representing the Contractor Provider must be identified and contact information provided to the City of Brookhaven's project manager and Call Center for all issues, as required, regarding the project for any safety, signage, erosion control, or other emergency as needed.
14. **This is a Linear project** with limited areas for storing materials. The Contractor Provider is responsible for coordinating stockpiled materials with any affected property owner. No storage will be allowed in areas that could impact the traffic flow or impede site visibility.
15. The Contractor Provider's performance will be measured based on the following:
  - Compliance with the Scope of Work.
  - Meeting the agreed-upon schedule dates.
  - Submission of all deliverables as specified.

**\*\*\*\*\*END EXHIBIT B\*\*\*\*\***

## EXHIBIT C

### INFORMATION REQUESTED TO ASSIST IN THE DETERMINATION OF RESPONSIBILITY

Bidders shall provide the following information on the attached sheets; this information shall be submitted with the bid in the format specified. Respond to each section of the information, on a separate sheet of paper, preferably typewritten, and attached to the bid at the time it is submitted. Failure to provide the information requested in complete and accurate detail may result in rejection of the bid.

#### **1. History and Organizational Structure of the Firm**

Provide a cover letter introducing the company and including the corporate name, address, and telephone number of the corporate headquarters and/or local office. The name and phone number of the Contractor Provider's project manager and/or one individual who will be the company's primary contact with the City of Brookhaven's project manager. This information is usually disclosed at the pre-construction meeting. A brief history of the company showing its present organizational structure and a summary of the management, organization, permanent employees by discipline, and the coordination structure of the personnel cogent to this project. If the firm is a partnership, indicate the name of all partners. If incorporated, indicate where and when. If the Contractor Provider has changed names, merged with, bought out by another company, or has changed incorporation status within the last five (5) years, list all such preceding organizations and a brief reason for the change. Contractor Provider shall also provide a business license indicating that the Contractor Provider can conduct business in Brookhaven. Further, the Contractor shall provide documentation showing that the Contractor is properly registered to conduct business in the State of Georgia. The Contractor Provider acknowledges and agrees that any business license and registration must remain current for the duration of the contract period and that such documents are material in terms of this agreement.

#### **2. References**

List as references (names, addresses, contact persons, and office and cellular phone numbers) a minimum of three (3) government municipalities or other clients of similar size and nature to the City of Brookhaven for which a project comparable to the scope of this project was completed.

#### **3. Subcontractors**

Indicate the names, addresses, and degree of utilization of all potential subcontractors that the Contractor Provider may utilize in the performance of this Contract.

#### **4. Previous Default**

Indicate if you, or any predecessor organization, have ever defaulted on a contract or been denied a bid due to non-responsibility to perform. If so, provide the facts and circumstances. If your firm or any successor organization is currently involved in any litigation or has, in the past ten (10) years, been involved in litigation with owners, please list the parties to the litigation, the civil action number, and a brief explanation of the matter.

**EXHIBIT D**  
**BOND DOCUMENTS**  
**BONDING REQUIREMENTS**

Each bid must be accompanied by a BID BOND (certified checks or other forms of surety are not acceptable) in an amount equal to five percent (5%) of the base bid, payable to the City of Brookhaven. Said bid bond guarantees the bidder will enter into a contract to construct the project strictly within the terms and conditions stated in this bid, and the associated bidding and contract documents, should the construction contract be awarded.

- The Successful Bidder shall be required to furnish a bond for the faithful performance of the contract and a bond to secure payment of all claims for materials furnished and labor performed in the performance of the project, both in amounts equal to one hundred percent (100%) of the contract price.
- The Successful Bidder shall also be required to furnish a Maintenance Bond, in the amount of one-third (1/3) of the contract price, guaranteeing the repair or replacement caused by defective workmanship or materials for one (1) year from the completion of construction.
- Bonds shall be issued by a corporate surety appearing on the Treasury Department's most current list (Circular 570 as amended) and be authorized to do business in the State of Georgia.
- The date of the Bond must not be before the date of the Contract. If the Contractor is a Partnership, all partners shall execute the Bond.

**EXHIBIT D**  
**BOND DOCUMENTS**  
**BID BOND**

KNOW ALL MEN BY THESE PRESENTS, THAT: \_\_\_\_\_ AT:  
*(Name of Contractor)*

\_\_\_\_\_, a(n) \_\_\_\_\_,  
*(Address of Contractor)* *(Corporation/Partnership and or Individual)*

hereinafter called Principal, and \_\_\_\_\_, at  
*(Name of Surety)*

\_\_\_\_\_, A corporation of the State of \_\_\_\_\_,  
*(Address of Surety)*

and a surety authorized by law to do business in the State of Georgia, hereinafter called Surety, are held, and firmly bound unto: City of Brookhaven Georgia, 4362 Peachtree Road NE, Brookhaven, Georgia 30319, hereinafter referred to as Obligee, in the penal sum of \_\_\_\_\_  
*(Name of Obligee)* *(Address of Obligee)*

Dollars (\$ \_\_\_\_\_) in lawful money of the United States, for the payment of which sum well and truly to be made, we bind ourselves, our heirs, executors, administrators, and successors, jointly and severally, firmly by these presents.

WHEREAS, the Principal is about to submit, or has submitted, to the City of Brookhaven, Georgia, a proposal for furnishing materials, labor, and equipment for:

Invitation to Bid, No. **24-012**  
**2024 ADA Ramp/Sidewalk Repair Project**

WHEREAS the Principal desires to file this Bond under the law in place of a certified Bidder's check otherwise required to accompany this Proposal.

NOW, THEREFORE, the conditions of this obligation are such that if the bid is accepted, the Principal shall, within ten days after receipt of notification of the acceptance, execute a Contract per the Bid and upon the terms, conditions, and prices outlined in the form and manner required by the City of Brookhaven, Georgia, and execute a sufficient and satisfactory Performance Bond and Payment Bond payable to the City of Brookhaven, Georgia, each in an amount of 100% of the total Contract Price, in form and with security satisfactory to the City of Brookhaven, Georgia, and otherwise, to be and remain in full force and virtue in law; and the Surety shall, upon failure of the Principal to comply with any or all of the foregoing requirements within the time specified above, immediately pay to the City of Brookhaven, Georgia, upon demand, the amount hereof in good and lawful money of the United States of America, not as a penalty, but as liquidated damages.

PROVIDED, FURTHER, that Principal and Surety agree and represent that this bond is executed pursuant, to and under the applicable provisions of the Official Code of Georgia Annotated, as Amended, including, but not limited to, O.C.G.A. SS 13-10-1, et. Seg. And SS 3686-101, et. Seg. and is intended to be and shall be constructed as a bond in compliance with the requirements thereof.



**EXHIBIT D**  
**BOND DOCUMENTS**

Signed, sealed, and dated this \_\_\_\_ day of \_\_\_\_\_ A.D., 2024.

ATTEST:

\_\_\_\_\_  
*(Principal Secretary)*  
(SEAL)

\_\_\_\_\_  
*(Principal)*  
BY:

\_\_\_\_\_  
*(Witness to Principal)*

\_\_\_\_\_  
*(Address)*

\_\_\_\_\_  
*(Address)*

(SURETY) ..... \_\_\_\_\_

\_\_\_\_\_  
*(Address)*

ATTEST

BY: \_\_\_\_\_  
*(Attorney-in-Fact) and Resident Agent*

\_\_\_\_\_  
*(Attorney-in-Fact)*

(SEAL)

\_\_\_\_\_  
*(Witness as to Surety)*

\_\_\_\_\_  
*(Address)*

**EXHIBIT D**  
**BOND DOCUMENTS**

**PAYMENT BOND**

KNOW ALL MEN BY THESE PRESENTS, THAT: \_\_\_\_\_ AT:  
\_\_\_\_\_, a(n) \_\_\_\_\_,  
*(Address of Contractor Provider)* *(Corporation/Partnership and or Individual)*  
hereinafter called Principal, and \_\_\_\_\_, at  
\_\_\_\_\_,  
*(Address of Surety)* A corporation of the State of \_\_\_\_\_,

and a surety authorized by law to do business in the State of Georgia, hereinafter called Surety,  
are held, and firmly bound unto: City of Brookhaven Georgia, 4362 Peachtree Road NE,

Brookhaven, Georgia 30319, hereinafter referred to as Obligee, in the penal sum of  
\_\_\_\_\_ Dollars (\$ \_\_\_\_\_) in lawful money of the United  
States, for the payment of which sum well and truly to be made, we bind ourselves, our heirs,  
executors, administrators and successors, jointly and severally, firmly by these presents.

The City of Brookhaven Georgia, 4362 Peachtree Road NE, Brookhaven, Georgia 30319  
*(Name of Obligee)* *(Address of Obligee)*

Hereinafter referred to as Obligee; for the use and protection of all subcontractors and all persons  
supplying labor, services, skill, tools, machinery, materials, and equipment in the prosecution of  
the work provided for in the contract hereinafter referred to in the full and just sum of  
\_\_\_\_\_ Dollars (\$ \_\_\_\_\_) in lawful money of  
the United States, for the payment of which sum well and truly to be made, we bind ourselves, our  
heirs, executors, administrators, and successors, jointly and severally, firmly by these presents in  
lawful money of the United States, for the payment of which sum well and truly to be made, the  
Principal and Surety bind themselves, their, and each of their heirs, executors, administrators,  
successors and assigns, jointly and severally, firmly by these presents.

The condition of this obligation is such, as whereas the Principal entered a certain contract, hereto  
attached, with the Obligee, dated \_\_\_\_\_ for \_\_\_\_\_.

NOW, THEREFORE, the conditions of this obligation are such that if the Principal shall well,  
truly, and faithfully perform said Contract per its terms, covenants, and conditions, and shall  
promptly pay all persons furnishing labor, materials, services, skill, tools, machinery and/or  
equipment for use in the performance of said Contract, then this obligation shall be void;  
otherwise, it shall remain in full force and effect. All persons who have furnished labor, materials,  
services, skills, tools, machinery, and equipment for use in the performance of said Contract shall  
have a direct right of action on this Bond, provided payment has not been made in full within  
ninety (90) days after the last day on which labor was performed, materials, services, skill, tools,  
machinery, and equipment furnished, or the subcontract completed.

PROVIDED FURTHER, that said Surety to this Bond, for value received, hereby stipulates and  
agrees that no change, extension of time, alterations, or additions, to the terms of the Contract or  
to the Work to be performed thereunder shall in any way affect its obligation on this bond, and it  
does hereby waive notice of any such change, extension of time, alterations, or additions to the  
terms of the Contract or to the work to be performed thereunder.

**EXHIBIT D**

**BOND DOCUMENTS**

PROVIDED, HOWEVER, that no suit or action shall be commenced hereunder by any person furnishing labor, materials, services, skill, tools, machinery, and/or equipment having a direct contractual relationship with a subcontractor, but no contractual relationship express or implied with the Principal:

*Unless such person shall have given notice to the Principal within 120 days after such person did, or performed the last of the work or labor, or furnished the last of the materials, services, skill, tools, machinery, and equipment for which the claim is made, stating with substantial accuracy the amount claimed and the name of the party to whom the materials, services, skill, tools, machinery, and/or equipment were furnished, or for whom they work or labor was done or performed. Such notice shall be served by mailing the same by registered mail, postage prepaid, in an envelope addressed to the Principal, at any place where an office is regularly maintained for the transaction of business, or served in any manner in which legal process may be served in the State in which the aforesaid project is located, save that such Contractor need not be made by a public officer, and a copy of such notice shall be delivered to the Obligee, to the person and at the address provided for in the Contract, within five days of the mailing of the notice to the Principal.*

PROVIDED FURTHER, that any suit under this Bond must be instituted before the expiration of one year after the acceptance of the public works covered by the Contract by the proper authorities.

PROVIDED FURTHER, that Principal and Surety agree and represent that this bond is executed according to and under the applicable provision of the Official Code of Georgia Annotated, as amended, including, but not limited to, O.C.G.A. SS 13-10-1, et. Eq. and SS 36-86-101, et. Seg. and is intended to be and shall be construed as a bond in compliance with the requirements, therefore.

Signed, sealed, and dated this \_\_\_\_ day of \_\_\_\_\_ A.D., 2024.

ATTEST:

\_\_\_\_\_  
*(Principal Secretary)*  
(SEAL)

\_\_\_\_\_  
*(Principal)*  
BY: \_\_\_\_\_

\_\_\_\_\_  
*(Witness to Principal)*

\_\_\_\_\_  
*(Address)*

\_\_\_\_\_  
*(Address)*

(SURETY) ..... \_\_\_\_\_

\_\_\_\_\_  
*(Address)*

ATTEST

BY: \_\_\_\_\_  
*(Attorney-in-Fact) and Resident Agent*

\_\_\_\_\_  
*(Attorney-in-Fact)*

(SEAL)

\_\_\_\_\_  
*(Witness as to Surety)*

\_\_\_\_\_  
*(Address)*

**EXHIBIT D**  
**BOND DOCUMENTS**  
**PERFORMANCE BOND**

KNOW ALL MEN BY THESE PRESENTS, THAT: \_\_\_\_\_ AT:  
*(Name of Contractor)*

\_\_\_\_\_, a(n) \_\_\_\_\_,  
*(Address of Contractor)* *(Corporation/Partnership and or Individual)*  
hereinafter called Principal, and \_\_\_\_\_, at  
*(Name of Surety)*  
\_\_\_\_\_, A corporation of the State of \_\_\_\_\_,  
*(Address of Surety)*

and a surety authorized by law to do business in the State of Georgia, hereinafter called Surety, are held, and firmly bound unto: City of Brookhaven Georgia, 4362 Peachtree Road NE,  
*(Name of Obligee)* *(Address of Obligee)*

Brookhaven, Georgia 30319, hereinafter referred to as Obligee, in the penal sum of \_\_\_\_\_ Dollars (\$ \_\_\_\_\_) in lawful money of the United States, for the payment of which sum well and truly to be made, we bind ourselves, our heirs, executors, administrators and successors, jointly and severally, firmly by these presents.

The City of Brookhaven Georgia, 4362 Peachtree Road NE, Brookhaven, Georgia 30319.  
*(Name of Obligee)* *(Address of Obligee)*

Hereinafter referred to as Obligee; for the use and protection of all subcontractors and all persons supplying labor, Contractor skill, tools, machinery, materials and/or equipment in the prosecution of the work provided for in the contract hereinafter referred to in the full and just sum of \_\_\_\_\_ Dollars (\$ \_\_\_\_\_) in lawful money of the United States, for the payment of which sum well and truly to be made, we bind ourselves, our heirs, executors, administrators and successors, jointly and severally, firmly by these presents in lawful money of the United States, for the payment of which sum well and truly to be made, the Principal and Surety bind themselves, their, and each of their heirs, executors, administrators, successors and assigns, jointly and severally, firmly by these presents.

The condition of this obligation is such, as whereas the Principal entered a certain contract, hereto attached, with the Obligee, dated \_\_\_\_\_ for \_\_\_\_\_.

NOW THEREFORE, the conditions of this obligation are such that if the above-bound Principal shall well, truly, fully and faithfully perform said contract According to its terms, covenants, conditions, and agreements of said contract during the original term of said contract and any extensions thereof that may be granted by the obligee, with or without notice to the Surety, and during the life of any guaranty required under the contract, and shall also well and truly perform and fulfill all the undertakings, covenants, terms, conditions and agreement of any and all duly authorized modifications of said contract that may hereafter be made, then his obligation shall be void, otherwise to remain in full force and effect.

PROVIDED FURTHER, that said Surety to this Bond, for value received, hereby stipulates and agrees that no change, extension of time, alterations, or additions to the terms of the Contract or to the Work to be performed thereunder shall in any way affect its obligation on this bond, and it does hereby waive notice of any such change, extension of time, alterations, or additions to the terms of the Contract or to the work to be performed thereunder.

PROVIDED FURTHER, that Principal and Surety agree and represent that this bond is executed pursuant to and in accordance with the applicable provisions of the Official Code of Georgia Annotated, as amended, including but not limited t. O. C.G.A. SS 13-10-1 et. Eq. and SS 36-86-101, et Seg., and is intended to be and shall be construed as a bond in compliance with the requirements thereof.

**EXHIBIT D**

**BOND DOCUMENTS**

Signed, sealed, and dated this \_\_\_\_ day of \_\_\_\_\_ A.D., 2024.

ATTEST:

\_\_\_\_\_  
*(Principal Secretary)*  
(SEAL)

\_\_\_\_\_  
*(Principal)*  
BY: \_\_\_\_\_

\_\_\_\_\_  
*(Witness to Principal)*

\_\_\_\_\_  
*(Address)*

\_\_\_\_\_  
*(Address)*

(SURETY) ..... \_\_\_\_\_

\_\_\_\_\_  
*(Address)*

ATTEST

BY: \_\_\_\_\_  
*(Attorney-in-Fact) and Resident Agent*

\_\_\_\_\_  
*(Attorney-in-Fact)*

(SEAL)

\_\_\_\_\_  
*(Witness as to Surety)*

\_\_\_\_\_  
*(Address)*

**EXHIBIT D**  
**BOND DOCUMENTS**  
**MAINTENANCE BOND**

**PROJECT NO:** \_\_\_\_\_

**BOND NO:** \_\_\_\_\_

KNOW ALL MEN BY THESE PRESENTS that we, \_\_\_\_\_ as Principal, and \_\_\_\_\_ as Surety, are held and firmly bound unto the CITY OF BROOKHAVEN, GEORGIA, as Obligee in the sum of one-third of the contract bid for the payment of which said Principal and Surety bind themselves, their heirs, administrators, executors, successors and assigns jointly and severally, firmly by these presents.

WHEREAS, the Principal has entered into an agreement with the City of Brookhaven for the Recreation and Parks Restroom Project. Said work has now been completed and the Obligee desires a maintenance bond guarantee said streets and improvements for one year beginning \_\_\_\_\_ and ending \_\_\_\_\_.

NOW, THEREFORE, THE CONDITION OF THIS OBLIGATION IS SUCH, that if the Principal shall fully indemnify and save harmless the City of Brookhaven from any loss, costs, expenses, or damages, for any repairs or replacements required because of defective workmanship or materials in said construction, then this obligation shall be null and void; otherwise to be and remain in full force and effect as to any such claim arising within one year from the completion of said construction as outlined in said agreement.

**Signed, sealed, and dated this \_\_\_\_\_ day of \_\_\_\_\_, 2024.**

Witness:

\_\_\_\_\_  
*(Principal)*

\_\_\_\_\_  
*(Name of Surety Company)*

\_\_\_\_\_  
*(Attorney-in-fact)*

*End of Exhibit D.*

**EXHIBIT E**  
**GEORGIA SECURITY AND IMMIGRATION COMPLIANCE ACT AFFIDAVIT**

Contractor(s) Name: \_\_\_\_\_

Address: \_\_\_\_\_

By executing this affidavit, the undersigned person or entity verifies its compliance with O.C.G.A. § 1310-91, stating affirmatively that the individual, firm, or corporation that is registered with, is authorized to participate in, and is participating in the federal work authorization program commonly known as E-Verify™,\* under the applicable provisions and deadlines established in O.C.G.A. § 13-10-91.

The undersigned person or entity further agrees that it will continue to use the federal work authorization program throughout the contract period, and it will contract for the physical performance of Services in satisfaction of such contract only with subcontractors who present an affidavit to the undersigned with the information required by O.C.G.A. § 13-10-91(b).

The undersigned person or entity further agrees to maintain records of such compliance and provide a copy of each such verification to the City of Brookhaven within five (5) business days after any subcontractor(s) is/are retained to perform such Contractor.

\_\_\_\_\_  
*(E Verify™ Company Identification Number)*

\_\_\_\_\_  
*(Date of Authorization)*

\_\_\_\_\_  
*BY: Authorized Officer or Agent*  
*(Name of Person or Entity)*

\_\_\_\_\_  
*(Date)*

SUBSCRIBED AND SWORN BEFORE ME ON THIS THE \_\_\_\_\_ DAY OF \_\_\_\_\_, 2024.

\_\_\_\_\_  
Notary Public

[NOTARY SEAL]

My Commission Expires: \_\_\_\_\_  
*(mm/dd/yyyy)*

**\* or any subsequent replacement operated by the United States Department of Homeland Security, or any equivalent federal work authorization program operated by the United States Department of Homeland Security to verify information of newly hired employees, pursuant to the Immigration Reform and Control Act of 1986 (IRCA), P.L. 99-603.**

**EXHIBIT E**  
**GEORGIA SECURITY AND IMMIGRATION COMPLIANCE ACT AFFIDAVIT**  
**Subcontractor Affidavit under O.C.G.A. § 13-10-91(b)(3)**

By executing this affidavit, the undersigned subcontractor verifies its compliance with O.C.G.A. § 13-10-91, stating affirmatively that the individual, firm, or corporation which is engaged in the physical performance of Services under a contract with \_\_\_\_\_ on behalf of

*(Name of Contractor)*

\_\_\_\_\_ has registered with, is authorized to use, and uses the  
*(Name of Public Employer)*

work authorization program commonly known as E-Verify, or any subsequent replacement program, following the applicable provisions and deadlines established in O.C.G.A. § 13-10-91. Furthermore, the undersigned subcontractor will continue to use the federal work authorization program throughout the contract period and the undersigned subcontractor will contract for the physical performance of Services in satisfaction of such contract only with sub-subcontractors who present an affidavit to the subcontractor with the information required by O.C.G.A. § 13-10-91(b). Additionally, the undersigned subcontractor will forward notice of the receipt of an affidavit from a sub-subcontractor to the contractor within five business days of receipt. If the undersigned subcontractor receives notice that a sub-subcontractor has received an affidavit from any other contracted sub-subcontractor, the undersigned subcontractor must forward, within five business days of receipt, a copy of the notice to the contractor. Subcontractor hereby attests that its federal work authorization user identification number and date of authorization are as follows:

\_\_\_\_\_  
*(Federal Work Authorization User I.D Number)*

\_\_\_\_\_  
*(Date of Authorization)*

\_\_\_\_\_  
*(Name of Subcontractor)*

\_\_\_\_\_  
*(Name of Project)*

\_\_\_\_\_  
*(Name of Public Employer)*

SUBSCRIBED AND SWORN BEFORE ME ON THIS THE \_\_\_\_ DAY OF \_\_\_\_\_, 2024.

[NOTARY SEAL]

\_\_\_\_\_  
Notary Public

My Commission Expires: \_\_\_\_\_  
*(mm/dd/yyyy)*

*End of Exhibit E.*



**EXHIBIT F  
DRUG-FREE WORKPLACE**

The undersigned certifies that the provisions of Code Sections 50-24-1 through 50-24-6 of the Official Code of Georgia Annotated, relating to the "Drug-free Workplace Act", have been complied with in full.

The undersigned further certifies that:

(1) A Drug-free workplace will be provided for the Contractor Provider's employees during the performance of the Contract; and

(2) Each Contractor Provider who hires a subcontractor to work in a Drug-free workplace shall secure from the subcontractor the following written certification: "As part of the subcontracting agreement with

\_\_\_\_\_ *(Contractor Provider)* \_\_\_\_\_ *(Subcontractor)*  
certifies to the Contractor Provider that a Drug-free workplace will be provided for the subcontractor's employees during the performance of this Contract according to paragraph (7) of subsection (b) of Code Section 50-24-03."

Also, the undersigned further certifies that he/she will not engage in the unlawful manufacture, sale, distribution, dispensation, possession, or use of a controlled substance or marijuana during the performance of the Contract.

Company Name: \_\_\_\_\_

BY: \_\_\_\_\_ Date \_\_\_\_\_  
*(Contractor Provider Signature, Authorized Officer, or Agent)* *(mm/dd/yyyy)*

\_\_\_\_\_  
*(Title of Authorized Officer or Agent of Contractor Provider)*

\_\_\_\_\_  
*(Printed Name of Authorized Officer or Agent)*

***End of Exhibit F.***

**EXHIBIT G**  
**PURCHASING POLICY ADDENDUM**

I, \_\_\_\_\_, hereby certify that I have received a copy of the City of Brookhaven, GA,  
*(Contractor Provider)*  
and agree to comply with all requirements of the City of Brookhaven, GA Financial Management Policies Purchasing Policy to the extent the policy applies to the undersigned.

Financial Management Policies Purchasing Policy can be found at:  
[cob- purchasing\\_policy\\_revised\\_march2020.pdf \(brookhavenga.gov\)](http://cob-purchasing_policy_revised_march2020.pdf)

BY: \_\_\_\_\_ Date \_\_\_\_\_  
*(Authorized Officer or Agent/Contractor Provider Signature (mm/dd/yyyy))*

\_\_\_\_\_  
*(Title of Authorized Officer or Agent of Contractor Provider)*

\_\_\_\_\_  
*(Printed Name of Authorized Officer or Agent (mm/dd/yyyy))*

***End of Exhibit G.***



**EXHIBIT I**  
**REFERENCES & SUBCONTRACTOR FORM**

**REFERNECES**

**2024 ADA Ramp/Sidewalk Repair**

Please provide as references the names of at least three (3) local corporate clients you have served for at least three (3) years.

1. Company Name: \_\_\_\_\_  
Address: \_\_\_\_\_  
Contact: \_\_\_\_\_ Phone: \_\_\_\_\_
2. Company Name: \_\_\_\_\_  
Address: \_\_\_\_\_  
Contact: \_\_\_\_\_ Phone: \_\_\_\_\_
3. Company Name: \_\_\_\_\_  
Address: \_\_\_\_\_  
Contact: \_\_\_\_\_ Phone: \_\_\_\_\_
4. Company Name: \_\_\_\_\_  
Address: \_\_\_\_\_  
Contact: \_\_\_\_\_ Phone: \_\_\_\_\_
5. Company Name: \_\_\_\_\_  
Address: \_\_\_\_\_  
Contact: \_\_\_\_\_ Phone: \_\_\_\_\_
6. Company Name: \_\_\_\_\_  
Address: \_\_\_\_\_  
Contact: \_\_\_\_\_ Phone: \_\_\_\_\_
7. Company Name: \_\_\_\_\_  
Address: \_\_\_\_\_  
Contact: \_\_\_\_\_ Phone: \_\_\_\_\_
8. Company Name: \_\_\_\_\_  
Address: \_\_\_\_\_  
Contact: \_\_\_\_\_ Phone: \_\_\_\_\_

**EXHIBIT I  
REFERENCES & SUBCONTRACTOR FORM**

**SUBCONTRACTORS**

**2024 ADA RAMP/SIDEWALK REPAIR**

Please provide the names, addresses, contact name and phone number of all Subcontractors that will be utilized by the Contractor for the duration of any resulting award.

1. Company Name: \_\_\_\_\_  
Address: \_\_\_\_\_  
Contact: \_\_\_\_\_ Phone: \_\_\_\_\_
  
2. Company Name: \_\_\_\_\_  
Address: \_\_\_\_\_  
Contact: \_\_\_\_\_ Phone: \_\_\_\_\_
  
3. Company Name: \_\_\_\_\_  
Address: \_\_\_\_\_  
Contact: \_\_\_\_\_ Phone: \_\_\_\_\_
  
4. Company Name: \_\_\_\_\_  
Address: \_\_\_\_\_  
Contact: \_\_\_\_\_ Phone: \_\_\_\_\_
  
5. Company Name: \_\_\_\_\_  
Address: \_\_\_\_\_  
Contact: \_\_\_\_\_ Phone: \_\_\_\_\_

*End of Exhibit I.*

**EXHIBIT J  
NON-COLLUSION AFFIDAVIT**

**2024 ADA RAMP/SIDEWALK REPAIR**

The undersigned bidder or agent, being duly sworn on oath, says that he/she has not, nor has any other member, representative, or agent of the firm, company, corporation or partnership represented by him, entered into any combination, collusion or agreement with any person relative to the price to be bid by anyone at such letting nor to prevent any person from bidding nor to include anyone to refrain from bidding, and that this bid is made without reference to any other bid and without any agreement, understanding or combination with any other person in reference to such bidding.

He/She further says that no person or persons, firms, or corporation has, have, or will receive directly or indirectly, any rebate, fee gift, commission, or thing of value on account of such sale.

**OATH AND AFFIRMATION**

I HEREBY AFFIRM UNDER THE PENALTIES FOR PERJURY THAT THE FACTS AND INFORMATION CONTAINED IN THE FOREGOING BID FOR PUBLIC WORKS ARE TRUE AND CORRECT.

Dated this \_\_\_\_\_ day of, \_\_\_\_\_

\_\_\_\_\_  
*(Name of Organization)*

\_\_\_\_\_  
*(Title of Person Signing)*

\_\_\_\_\_  
*(Signature)*

\_\_\_\_\_  
*(Bid Number)*

**ACKNOWLEDGEMENT**

STATE OF)

COUNTY OF)

Before me, a Notary Public, personally appeared the above named and swore that the statements contained in the foregoing document are true and correct.

Subscribed and sworn to me this \_\_\_\_ day of \_\_\_\_\_, 2024

\_\_\_\_\_  
*(Notary Signature)*

My Commission Expires: \_\_\_\_\_  
*(mm/dd/yyyy)*

***End of Exhibit J***

**EXHIBIT K  
BID SCHEDULE  
2024 ADA RAMP/SIDEWALK REPAIR**

**EXHIBIT K  
BID SCHEDULE  
(TASKS 1 & 2)**

**EXHIBIT K  
 BID SCHEDULE  
 2024 ADA RAMP/SIDEWALK REPAIR**

ADA RAMP AND SIDEWALK REPAIR/REPLACE: 2024: TASK2								
LOC #	STREET #	ROADWAY	RAMP TYPE	SW WIDTH	SW REPAIR LENGTH	TYPE OF REPAIR	COMMENTS	COST/LOCATION
1	1280	BRIARWOOD RD	N/A	4'	8	R&R 8FT OF SIDEWALK FROM THE WEST SIDE OF DRIVE, 8FT WEST (MARKED)	REMOVE TREE ROOTS	\$ -
2	1280	BRIARWOOD RD	N/A	4'	12	R&R 12FT OF SIDEWALK BETWEEN THE TWO DRIVEWAYS (MARKED).	REMOVE TREE ROOTS	\$ -
3	1280	BRIARWOOD RD	N/A	4'	20	R&R 20FT OF SIDEWALK FROM RAMP AT WEST SIDE INTERSECTION OF BRIARWOOD/LOGAN CIRCLE(MARKED).		\$ -
4	1292	BRIARWOOD RD	N/A	4'	4	R&R 4FT OF SIDEWALK BETWEEN THE NEW GOOGLE BOX AND THE RAMP AT THE EAST SIDE INTERSECTION OF BRIARWOOD/LOGAN CIR (MARKED).		\$ -
5	1292	BRIARWOOD RD	N/A	4'	4	R&R 4FT OF SIDEWALK TO THE IMMEDIATE EAST OF DRIVEWAY (MARKED).		\$ -
6	1300	BRIARWOOD RD	N/A	4'	12	R&R 12FT OF SIDEWALK NEAR MAILBOX, APPROX 75' N OF DRIVEWAY (MARKED).		\$ -
7	1300	BRIARWOOD RD	N/A	4'	8	R&R 8FT OF SIDEWALK AT MIDDLE OF PROPERTY, IMMEDIATELY S OF DRIVEWAY (MARKED).		\$ -
8	1322	BRIARWOOD RD	N/A	4'	4	R&R 4FT OF SIDEWALK FROM SOUTH SIDE OF DRIVE, APPROX 100' N OF DRIVEWAY (MARKED).		\$ -
9	1322	BRIARWOOD RD	N/A	4'	14	R&R 14FT OF SIDEWALK, APPROX 50' N OF DRIVEWAY (MARKED).		\$ -
10	1322	BRIARWOOD RD	N/A	4'	30	R&R 30FT OF SIDEWALK FROM FINISHED RAMP ON N SIDE OF DRIVEWAY, 30FT N (MARKED).		\$ -
11	1322	BRIARWOOD RD	D	4'	20	R&R TY D RAMP & ASSOC SIDEWALK/CURBING WITH TY D (SKEWED) RAMP, APPROX 20FT OF SIDEWALK, REQUIRED CURB & GUTTER AT S SIDE OF DRIVEWAY (MARKED).		\$ -
12	1322	BRIARWOOD RD	N/A	4'	10	R&R 10FT OF SIDEWALK APPROX 40' SOUTH OF DRIVEWAY (MARKED).		\$ -
13	1322	BRIARWOOD RD	N/A	4'	57	R&R 10FT OF SIDEWALK APPROX 75' SOUTH OF DRIVEWAY (MARKED).		\$ -



**EXHIBIT K  
 BID SCHEDULE  
 2024 ADA RAMP/SIDEWALK REPAIR**

ADA RAMP AND SIDEWALK REPAIR/REPLACE: 2024: TASK 2								
LOC #	STREET #	ROADWAY	RAMP TYPE	SW WIDTH	SW REPAIR LENGTH	TYPE OF REPAIR	COMMENTS	COST/LOCATION
14.1	NORTH OF THE INTERSECTION OF BRIARWOOD RD @ BRIARWOOD HILLS DR		N/A	4'	47	R&R SIDEWALK FROM N RAMP AT INTERSECTION TO 47FT NORTH (MARKED AS: 14.1).	<b>RAISE GAS VALVE TO MEET NEW SIDEWALK ELEVATION</b>	\$ -
14.2			N/A	4'	18	R&R 18FT OF SIDEWALK N OF INTERSECTION (MARKED AS: 14.2).		\$ -
14.3			N/A	4'	28	R&R 28FT OF SIDEWALK N OF INTERSECTION (MARKED AS: 14.3).		\$ -
14.4			N/A	4'	4	R&R 4FT OF SIDEWALK N OF INTERSECTION (MARKED AS: 14.4).		\$ -
15.1	NORTH OF THE INTERSECTION OF BRIARWOOD RD @ COOSAWATTEE DR		N/A	4'	88	R&R 4FT OF SIDEWALK N OF INTERSECTION (MARKED AS: 15.1).		\$ -
15.2			N/A	4'	4	R&R 4FT OF SIDEWALK N OF INTERSECTION (MARKED AS: 15.2).		\$ -
15.3			N/A	4'	10	R&R 4FT OF SIDEWALK N OF INTERSECTION (MARKED AS: 15.3).		\$ -

**EXHIBIT K  
 BID SCHEDULE  
 2024 ADA RAMP/SIDEWALK REPAIR**

ADA RAMP AND SIDEWALK REPAIR/REPLACE: 2024: TASK 2								
LOC #	STREET #	ROADWAY	RAMP TYPE	SW WIDTH	SW REPAIR LENGTH	TYPE OF REPAIR	COMMENTS	COST/LOCATION
16.1	<b>NORTH OF THE INTERSECTION OF BRIARWOOD RD @BRIARWOOD WAY</b>		N/A	5'	5	R&R 5FT OF SIDEWALK N OF INTERSECTION (MARKED AS: 16.1).		\$ -
16.1a			N/A	N/A	10	R&R ROLLED CURB, IN-KIND, N OF INTERSECTION (MARKED AS: 16.1a).		\$ -
16.2			D	5'	N/A	R&R TY D RAMP & ASSOC SIDEWALK/CURBING WITH TY D (SKEWED) RAMP @ S SIDE OF ENTRANCE TO CARLYLE WOODS APTS (MARKED AS: 16.2).		\$ -
16.3			D	5'	N/A	R&R TY D RAMP & ASSOC SIDEWALK/CURBING WITH TY D (SKEWED) RAMP @ N SIDE OF ENTRANCE TO CARLYLE WOODS APTS (MARKED AS: 16.3).		\$ -
16.4			N/A	4'	6	R&R 6FT OF SIDEWALK N OF INTERSECTION (MARKED AS: 16.4).		\$ -
16.5			N/A	4'	13	R&R 13FT OF SIDEWALK N OF INTERSECTION (MARKED AS: 16.5).		\$ -
16.6			N/A	4'	8	R&R 8FT OF SIDEWALK N OF INTERSECTION (MARKED AS: 16.6).	REMOVE TREE ROOTS	\$ -
16.7			N/A	4'	16	R&R 16FT OF SIDEWALK N OF INTERSECTION (MARKED AS: 16.7).	REMOVE TREE ROOTS	\$ -
16.8			N/A	4'	7	R&R 7FT OF SIDEWALK N OF INTERSECTION (MARKED AS: 16.8).	RAISE WATER VALVE TO MEET NEW SIDEWALK ELEVATION	\$ -
16.9			N/A	4'	28	R&R 28FT OF SIDEWALK N OF INTERSECTION (MARKED AS: 16.9).	REMOVE TREE ROOTS	\$ -
16.10			N/A	4'	7	R&R 7FT OF SIDEWALK N OF INTERSECTION (MARKED AS: 16.10).		\$ -
16.11			N/A	4'	30	R&R 30FT OF SIDEWALK N OF INTERSECTION (MARKED AS: 16.11).		\$ -

**EXHIBIT K  
 BID SCHEDULE  
 2024 ADA RAMP/SIDEWALK REPAIR**

ADA RAMP AND SIDEWALK REPAIR/REPLACE: 2024: TASK 2								
LOC #	STREET #	ROADWAY	RAMP TYPE	SW WIDTH	SW REPAIR LENGTH	TYPE OF REPAIR	COMMENTS	COST/LOCATION
16.12	<b>NORTH OF THE INTERSECTION OF BRIARWOOD RD @BRIARWOOD WAY</b>		N/A	4'	7	R&R 7FT OF SIDEWALK N OF INTERSECTION (MARKED AS: 16.12).		\$ -
16.13			N/A	4'	20	R&R 5FT OF SIDEWALK N OF INTERSECTION (MARKED AS: 16.13).	<b>REMOVE TREE ROOTS</b>	\$ -
16.14			N/A	4'	33	R&R 5FT OF SIDEWALK N OF INTERSECTION (MARKED AS: 16.14).	<b>REMOVE TREE ROOTS</b>	\$ -
16.15			N/A	4'	5	R&R 5FT OF SIDEWALK N OF INTERSECTION (MARKED AS: 16.15).		\$ -
16.16			N/A	4'	5	R&R 5FT OF SIDEWALK N OF INTERSECTION (MARKED AS: 16.16).		\$ -
16.17			N/A	5'	5	R&R 5FT OF SIDEWALK N OF INTERSECTION (MARKED AS: 16.17).		\$ -

**AGGREGATE COST (TASK 2): \$ \_\_\_\_\_**

**LUMP SUM TRAFFIC CONTROL (TASK 2) \$ \_\_\_\_\_**

**LUMP SUM TRAFFIC CONTROL: (TASK 1, FROM EXHIBIT L) \$ \_\_\_\_\_**

**LUMP SUM BID: (TASK 1, FROM EXHIBIT L) \$ \_\_\_\_\_**

**EXHIBIT K  
BID SCHEDULE  
2024 ADA RAMP/SIDEWALK REPAIR**

PRICE OF 4 FT WIDE SIDEWALK, 4" THICK: \$ \_\_\_\_\_ (LF)

PRICE OF 5 FT WIDE SIDEWALK, 4" THICK: \$ \_\_\_\_\_ (LF)

PRICE OF 5 FT SIDEWALK, 6" THICK: \$ \_\_\_\_\_ (LF)

TOTAL COST FOR TASK 1: \$ \_\_\_\_\_

TOTAL COST FOR TASK 2: \$ \_\_\_\_\_

TOTAL BID AMOUNT (TASK 1 + TASK 2): \$ \_\_\_\_\_

**Total Bid Amount in Words:**

\_\_\_\_\_

**Contractor Provider:** \_\_\_\_\_

**Signature:** \_\_\_\_\_

**Print Name:** \_\_\_\_\_

**Date:** \_\_\_\_\_

**\*\*THIS PAGE MUST BE COMPLETED AND SUBMITTED AS A PART OF YOUR BID\*\***

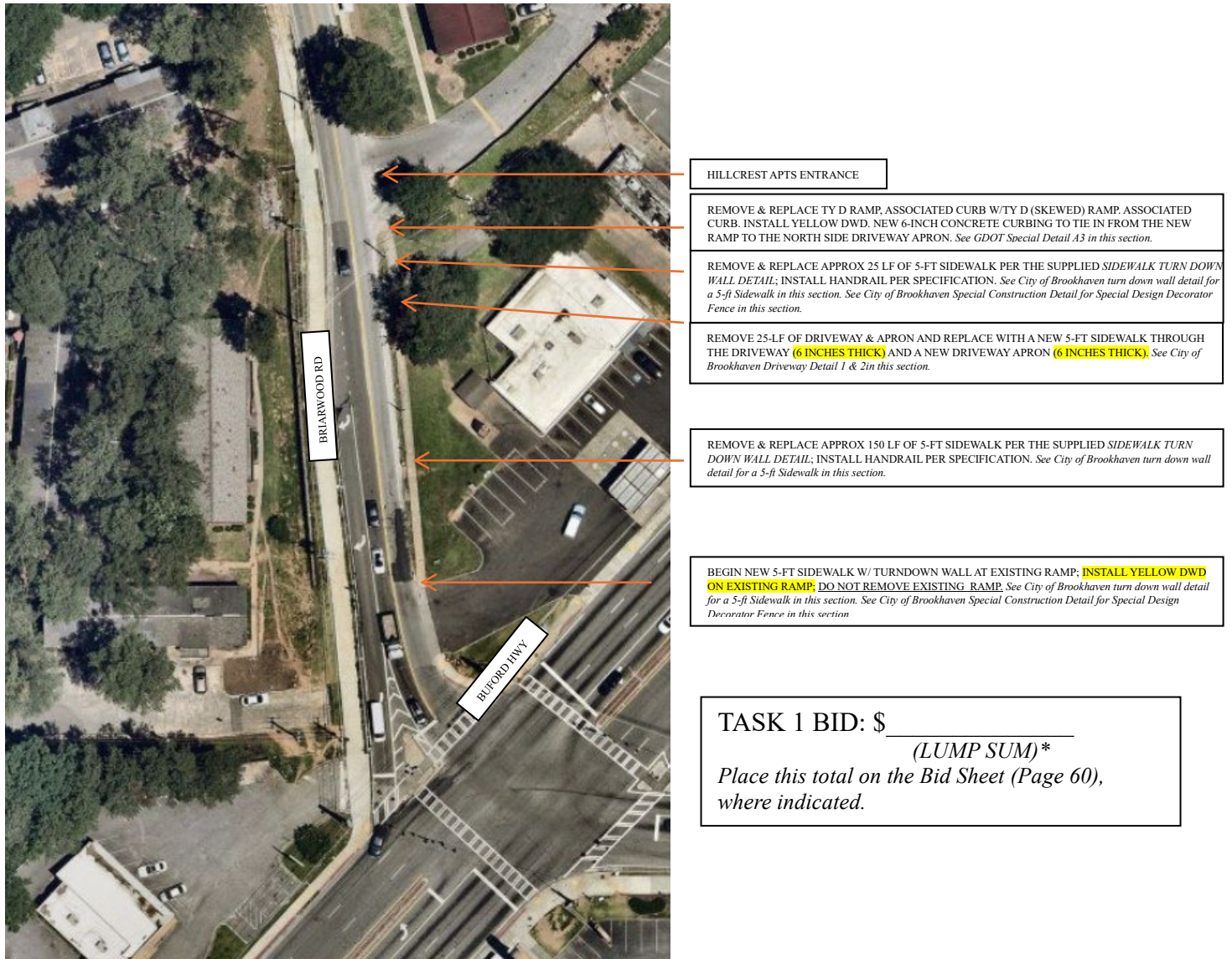
*END OF EXHIBIT K*

**EXHIBIT L (TASK 1)**  
**SPECIFICATIONS & DETAILS FOR ADA RAMP AND TURN-DOWN SIDEWALK**

**Description: TASK 1**

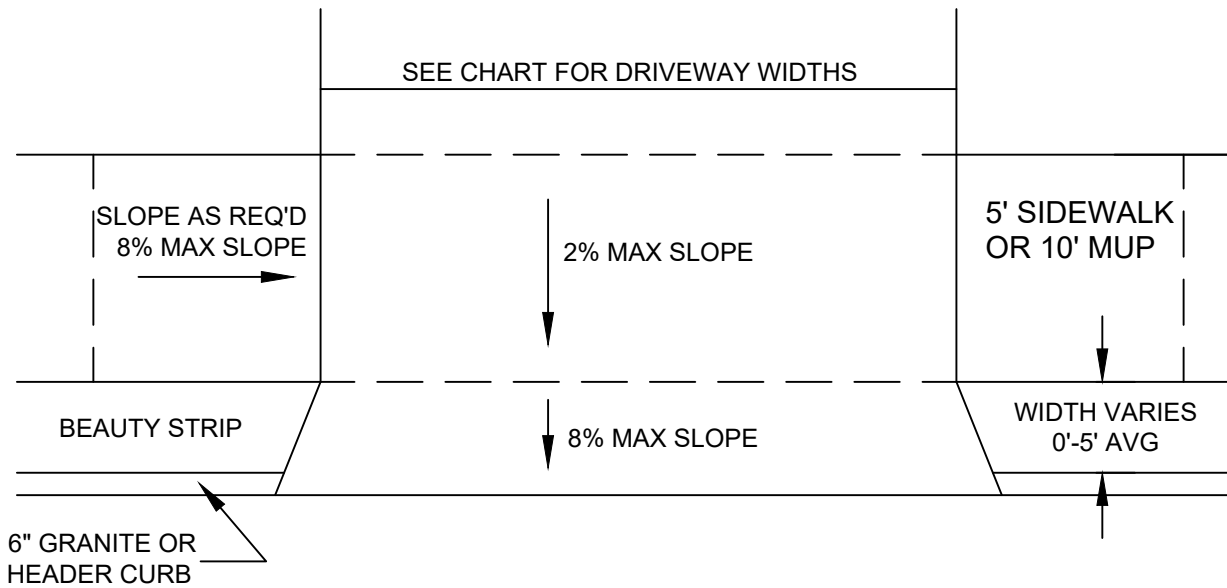
Removal & replacement of the existing TY D sidewalk ramp with a TY D (skewed) ramp and associated curbing located on the south side of the intersection of Briarwood Road and the south entrance to Hillcrest Apartments (3446 Buford Hwy), 22-ft driveway/apron/sidewalk entrance reconstruction to match new sidewalk elevations/slopes, and two sidewalk sections; 25-LF of 5-ft sidewalk with associated with the specified turndown wall and hand railing installed on the east side of the sidewalk from the south side of the new ramp at Hillcrest entrance to the north side of the driveway entrance; a 25-ft wide driveway entrance with a standard 5-ft sidewalk, conforming to the new min/max sidewalk slopes; and approximately 150-LF of turndown sidewalk/handrailing from the south side of the driveway entrance to the existing ramp on the north side of the Citgo station (3390 Buford Hwy) entrance located on Briarwood Road. Below is a map of the construction limits for Task 1.\*

Figure 1: AREA MAP OF TASK 1 CONSTRUCTION



\*Task 1 is a lump-sum bid. Traffic control, police presence, and flaggers are required and should be factored into the Task 1 Bid. Place this total on page 60 of the bid sheet (Exhibit K).

**EXHIBIT L (TASK 1)  
SPECIFICATIONS & DETAILS FOR ADA RAMP AND TURN-DOWN SIDEWALK**



DRIVEWAY WIDTH

TYPE	MINIMUM	MAXIMUM
RESIDENTIAL - SINGLE CAR GARAGE	10'	12'
RESIDENTIAL - TWO OR MORE CAR GARAGE	10'	20'
COMMERCIAL - ONE WAY	12'	20'
COMMERCIAL - TWO WAY	12'	24'

NOTES:

1. DRIVEWAYS SHALL BE CONSTRUCTED ACCORDING TO CITY STANDARDS IN 3000 PSI CONCRETE.
2. ORNAMENTAL BRICK OR STONEMWORK IN DRIVEWAY TO BE OUTSIDE LIMITS OF RIGHT-OF-WAY.
3. NO MATERIALS OTHER THAN CONCRETE SHALL BE USED FOR DRIVEWAY CONSTRUCTION.
4. ORNAMENTAL MAILBOXES ARE NOT PERMITTED WITHIN LIMITS OF RIGHT-OF-WAY. REMOVAL OF ORNAMENTAL MAILBOXES DUE TO ROADWAY OR OTHER INFRASTRUCTURE IMPROVEMENTS SHALL BE DONE AT PROPERTY OWNER EXPENSE.

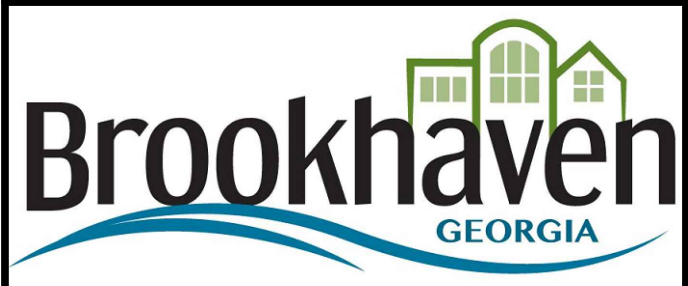
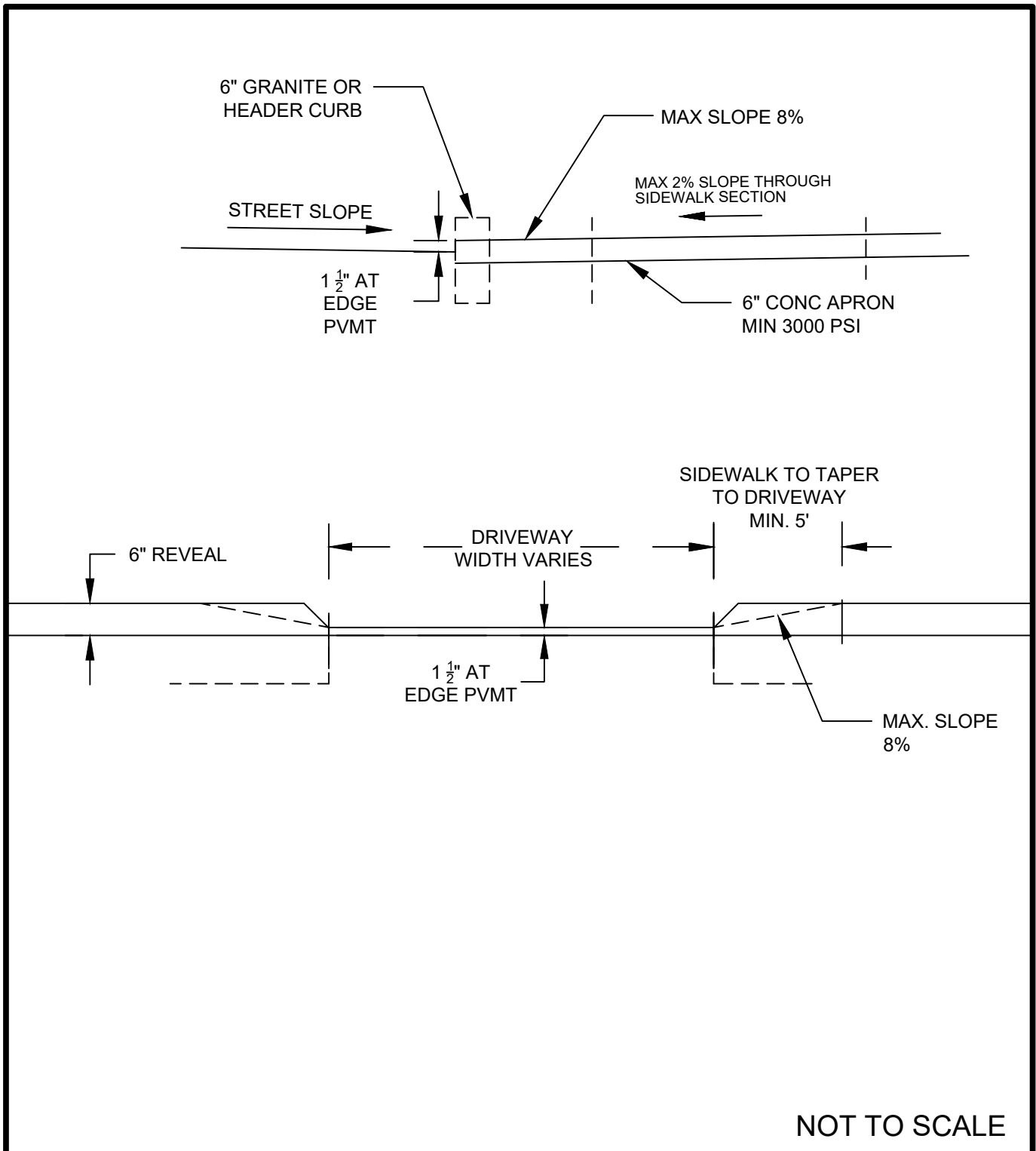
NOT TO SCALE



**CITY OF BROOKHAVEN  
PUBLIC WORKS DEPARTMENT  
DRIVEWAY DETAIL  
SHEET 1 OF 2**

DATE: DECEMBER 29, 2020

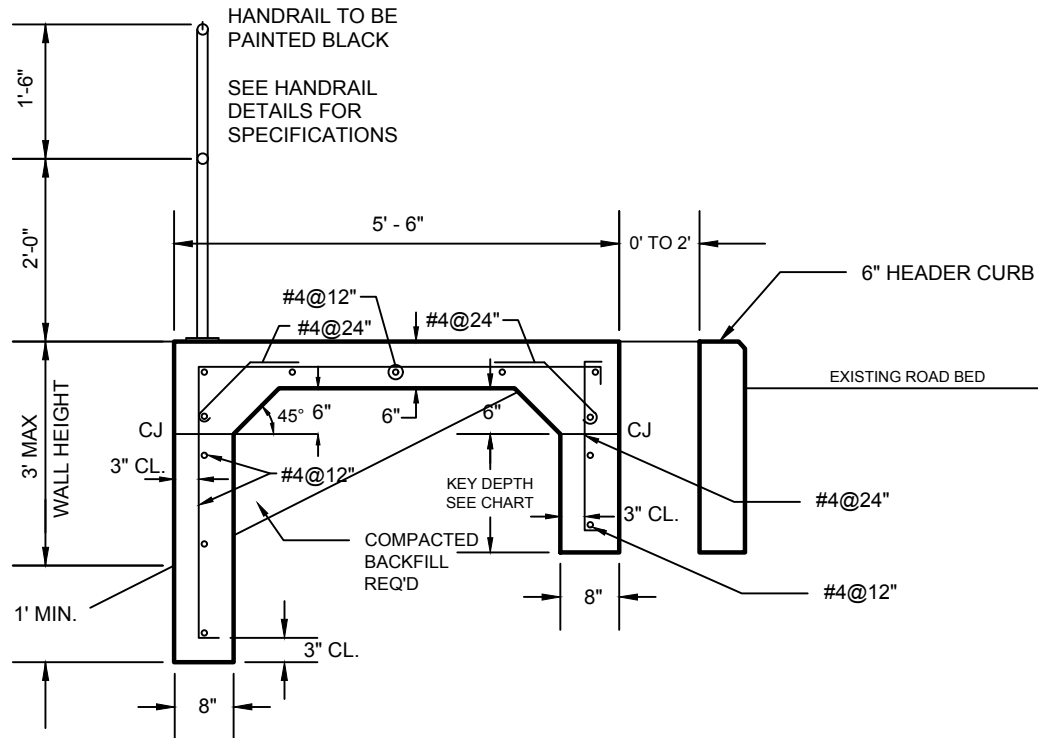
EXHIBIT L (TASK 1)  
SPECIFICATIONS & DETAILS FOR ADA RAMP AND TURN-DOWN SIDEWALK



CITY OF BROOKHAVEN  
PUBLIC WORKS DEPARTMENT  
DRIVEWAY DETAIL  
SHEET 2 OF 2

DATE: DECEMBER 29, 2020

**EXHIBIT L (TASK 1)  
SPECIFICATIONS & DETAILS FOR ADA RAMP AND TURN-DOWN SIDEWALK**



WALL HEIGHT	KEY DEPTH
1' - 0"	1' - 0" MIN.
2' - 0"	1' - 4"
3' - 0" MAX	1' - 8"

**LOADS:**  
SURCHARGE - 0 PSF

**MATERIALS:**  
CONCRETE -----  $f_c = 2,500$  PSI (MIN)  
REINFORCING -----  $f_y = 60,000$  PSI

**SOIL PROPERTIES:**  
SOIL WEIGHT = 110 PCF  
 $\phi = 28^\circ$   
C = 0  
ALLOWABLE SOIL PRESSURE = 3,000 PSF

- NOTE:**
- CONTRACTOR MUST TEMPORARILY SUPPORT FOOTING WALLS UNTIL TOP SLAB IS IN PLACE.
  - CONTRACTOR TO PROVIDE COMPACTED BACKFILL UNDER SLAB.

NOT TO SCALE



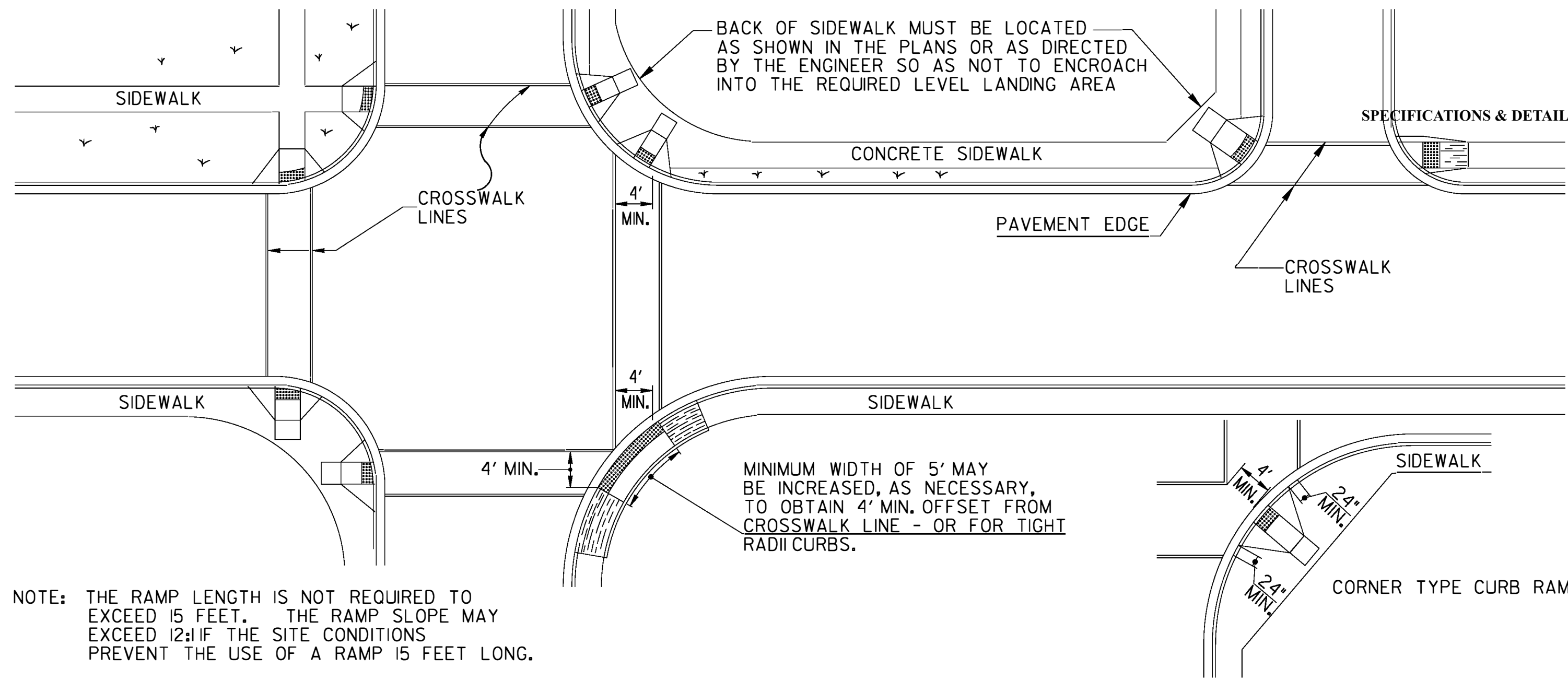
**CITY OF BROOKHAVEN  
PUBLIC WORKS DEPARTMENT  
TURN DOWN WALL DETAIL  
FOR 5' SIDEWALK**

APRIL 2018, REVISED JUNE 3, 2019



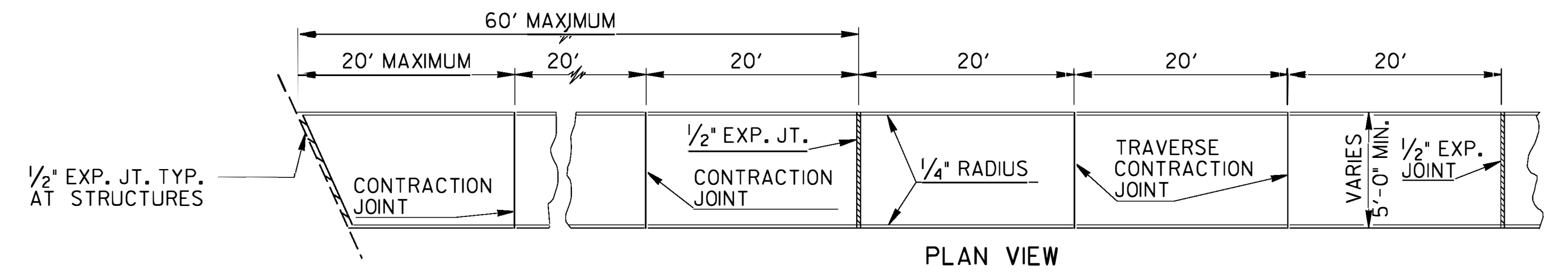
STATE	PROJECT NUMBER	SHEET NO.	TOTAL SHEETS
GA.	STP00-2868-00(00)	113	258

TYPICAL LOCATIONS FOR CURB CUT RAMPS - PLAN VIEW

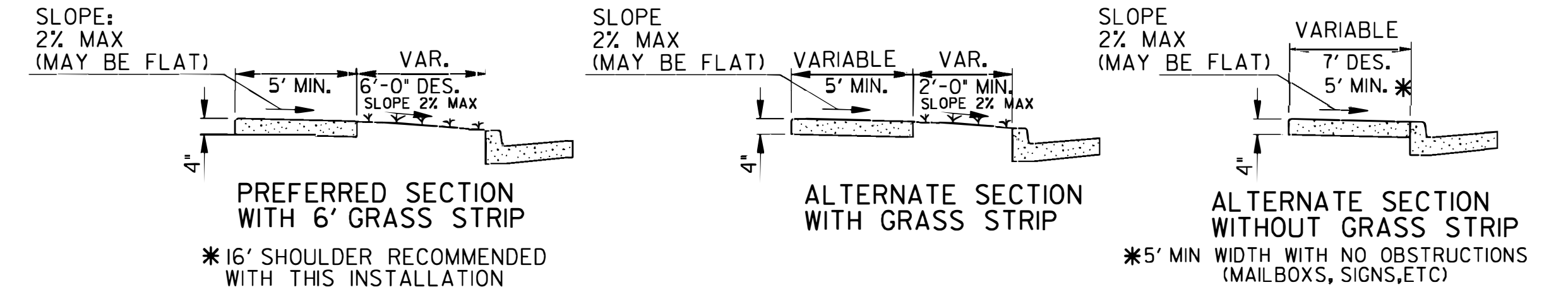
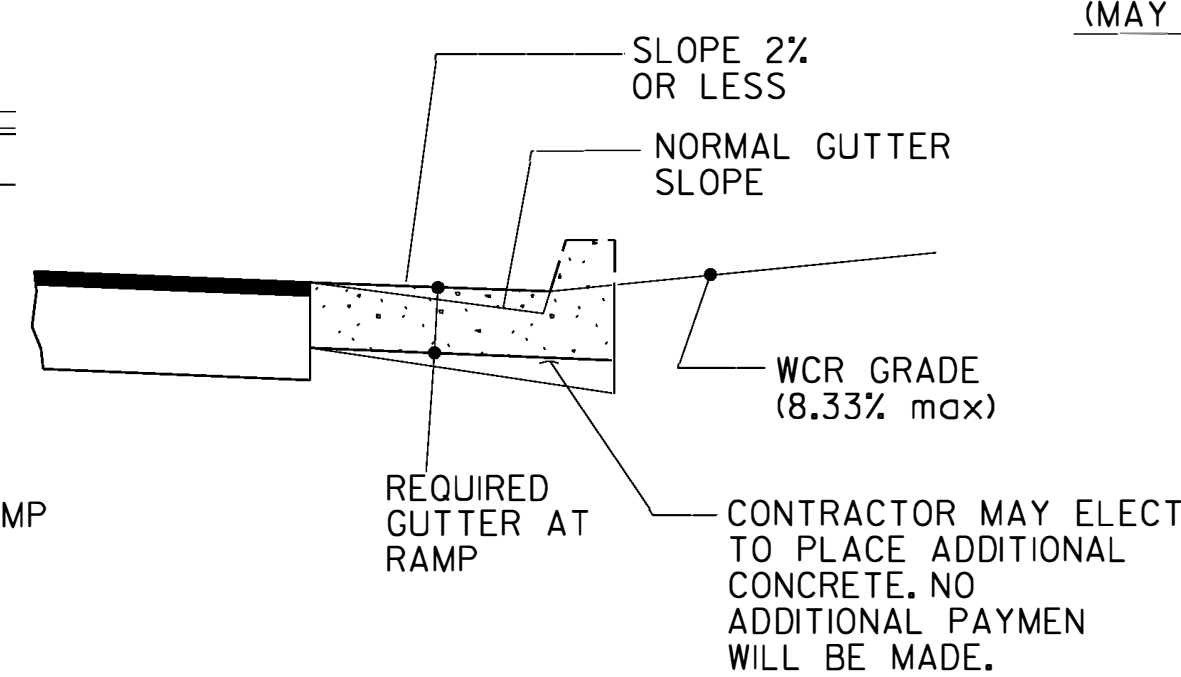


NOTE: THE RAMP LENGTH IS NOT REQUIRED TO EXCEED 15 FEET. THE RAMP SLOPE MAY EXCEED 12% IF THE SITE CONDITIONS PREVENT THE USE OF A RAMP 15 FEET LONG.

CONCRETE SIDEWALK DETAILS



GUTTER TRANSITION DETAIL



NOTES FOR CONCRETE SIDEWALK:

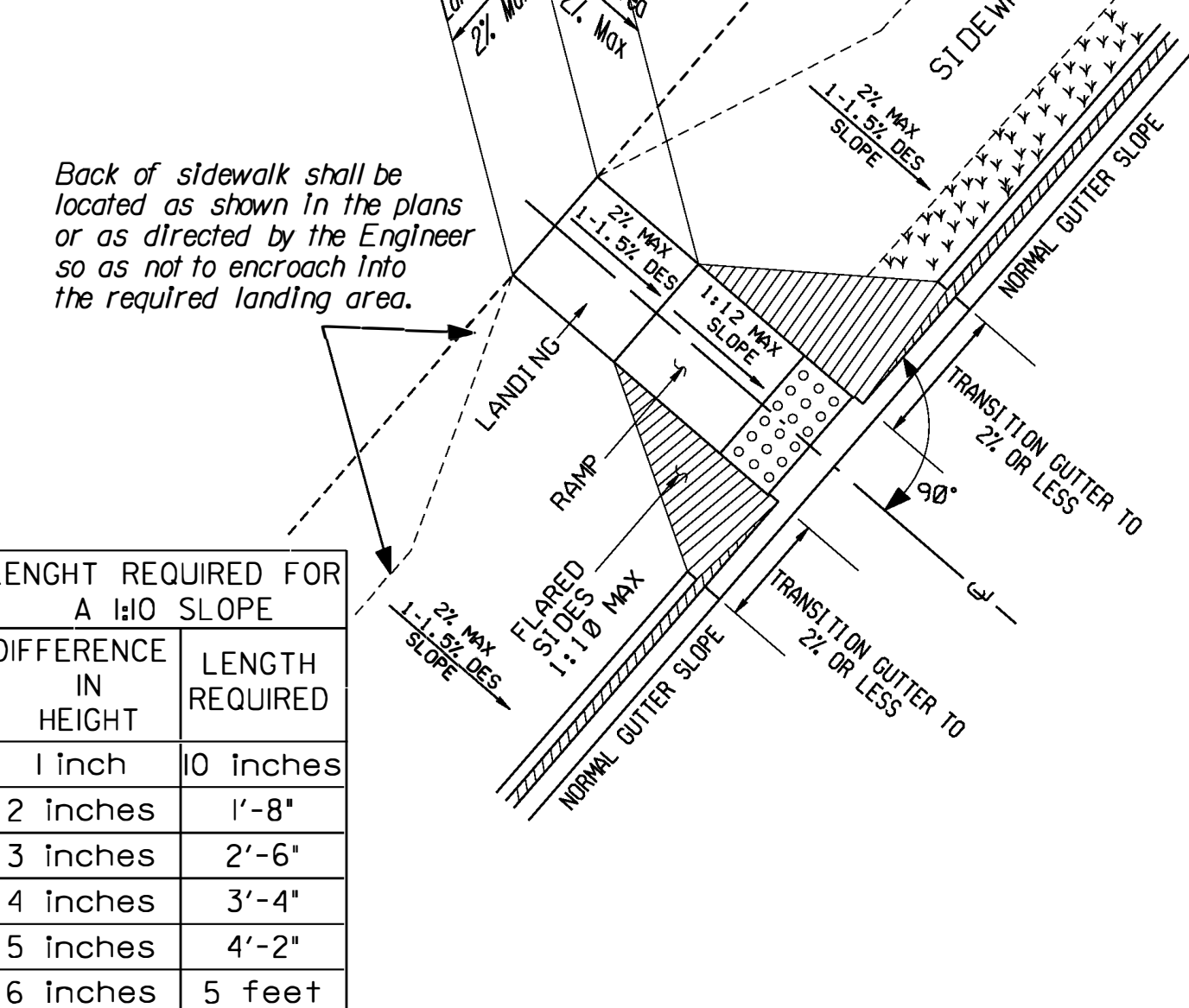
- A. CONCRETE TO BE PLACED 4" THICK AND FINISHED WITH TAMPS, WOOD FLOATS AND STIFF-BRISTLE BROOMS.
- B. TRANSVERSE CONTRACTION JOINTS SHALL BE PLACED AT 20 FT. INTERVALS. ALL EDGES TO BE ROUNDED TO 1/4" RADIUS.
- C. 1/2" EXPANSION JOINTS SHALL BE PLACED, WHERE SIDEWALK TIE INTO A STRUCTURE OR TERMINATE AT CURB, RAMPS OR DRIVEWAYS AND AT 60' INTERVALS.

NOTES FOR CURB CUT RAMPS:

1. CURB CUT RAMPS WILL BE LOCATED AS FOLLOWS UNLESS PLANS OR CONTRACT SPECIFY OTHERWISE.
  - a) AT ALL PEDESTRIAN CROSSWALKS WHERE CURB IS CONSTRUCTED OR REPLACED.
  - b) WHERE THE SIDEWALK, CONCRETE OR UNPAVED, IS INTERRUPTED BY THE CURB AT TURNOUTS OR AT INTERSECTIONS.
  - c) AT OTHER LOCATIONS SUCH AS HOSPITALS, NURSING HOMES, REST AREAS, ETC., WHERE THE CURB WOULD OTHERWISE BE AN OBSTRUCTION TO THE PHYSICALLY DISABLED.
2. RAMPS WILL BE CONSTRUCTED FROM CONCRETE. SPECIFICATIONS FOR RAMPS WILL BE THE SAME AS FOR CONCRETE SIDEWALK. RAMPS SHALL HAVE EITHER A ROUGH OR A TEXTURED FINISH.
3. DROP INLETS ARE NOT TO BE LOCATED DIRECTLY IN FRONT OF RAMPS. CATCH BASINS SHOULD BE LOCATED AT LEAST 10 FT. FROM RAMPS WHEN FEASIBLE.
4. WHERE RAMPS ARE LOCATED IN RADIUS, THE DIMENSIONS SHOWN FOR RAMP WIDTHS AND TAPERS ARE MEASURED PERPENDICULAR TO THE RAMP AND NOT ALONG THE CURVE.
5. WHERE UTILITY STRUCTURES CONFLICT, WHERE SIDEWALK GEOMETRY VARIES, AT SKEWED INTERSECTIONS, OR IN OTHER SPECIAL CASES, THE RAMP DESIGNS MAY BE MODIFIED BY THE DESIGNER OR ENGINEER, PROVIDED THAT THE WIDTH REMAINS A MINIMUM OF 48 INCHES, AND NO SLOPE ON THE ACCESSIBLE PART OF THE RAMP IS STEEPER THAN 12%.
6. 1 IN. FT. OF CURB AND GUTTER WILL INCLUDE THE TRANSITIONED CURB IN FRONT OF RAMPS. SO. YDS. OF CONCRETE SIDEWALK AND CONCRETE MEDIAN PAVING WILL INCLUDE RAMPS. NO ADDITIONAL PAYMENT WILL BE MADE FOR CURB RAMPS. NO ADDITIONAL PAYMENT WILL BE MADE FOR SAWING AND REMOVING EXISTING SIDEWALK OR CURB WHERE NECESSARY FOR RAMP CONSTRUCTION.
7. WHEN A CURB RAMP IS PLACED ON EXISTING PAVEMENT, THE PAVEMENT SHALL BE REMOVED TO PROVIDE A MINIMUM THICKNESS OF 3 INCHES OF CONCRETE AT ALL LOCATIONS. NO SEPARATE PAYMENT WILL BE MADE FOR REMOVAL OF THE PAVEMENT.
8. DETECTABLE WARNING SURFACES ARE REQUIRED ON ALL INTERSECTIONS WITH PUBLIC STREETS, SIGNALIZED COMMERCIAL DRIVEWAYS, AND COMMERCIAL DRIVEWAYS WITH AN AADT OF 25 VPD.

Type A

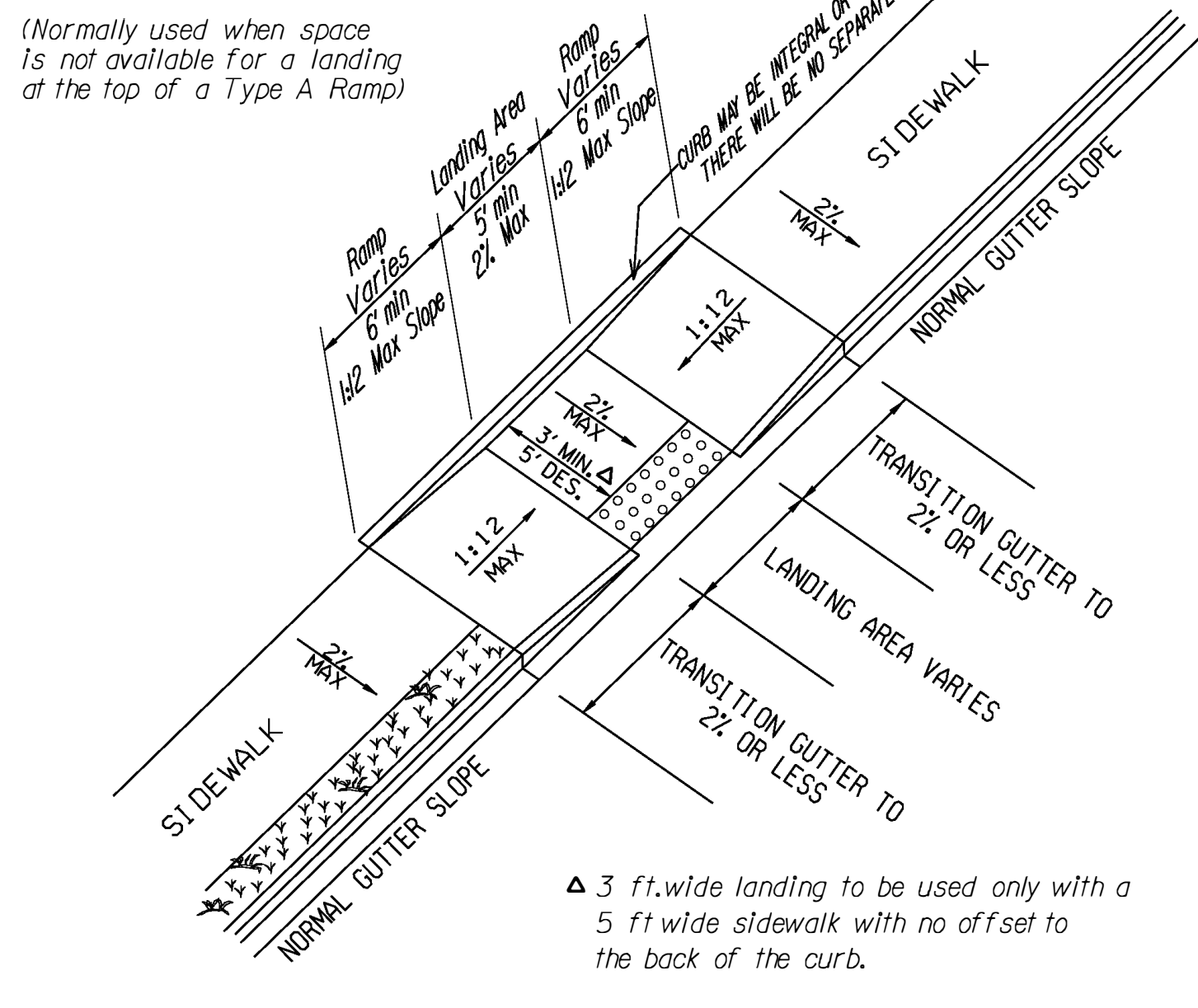
(The Preferred Ramp)



DIFFERENCE IN HEIGHT	LENGTH REQUIRED
1 inch	10 inches
2 inches	1'-8"
3 inches	2'-6"
4 inches	3'-4"
5 inches	4'-2"
6 inches	5 feet

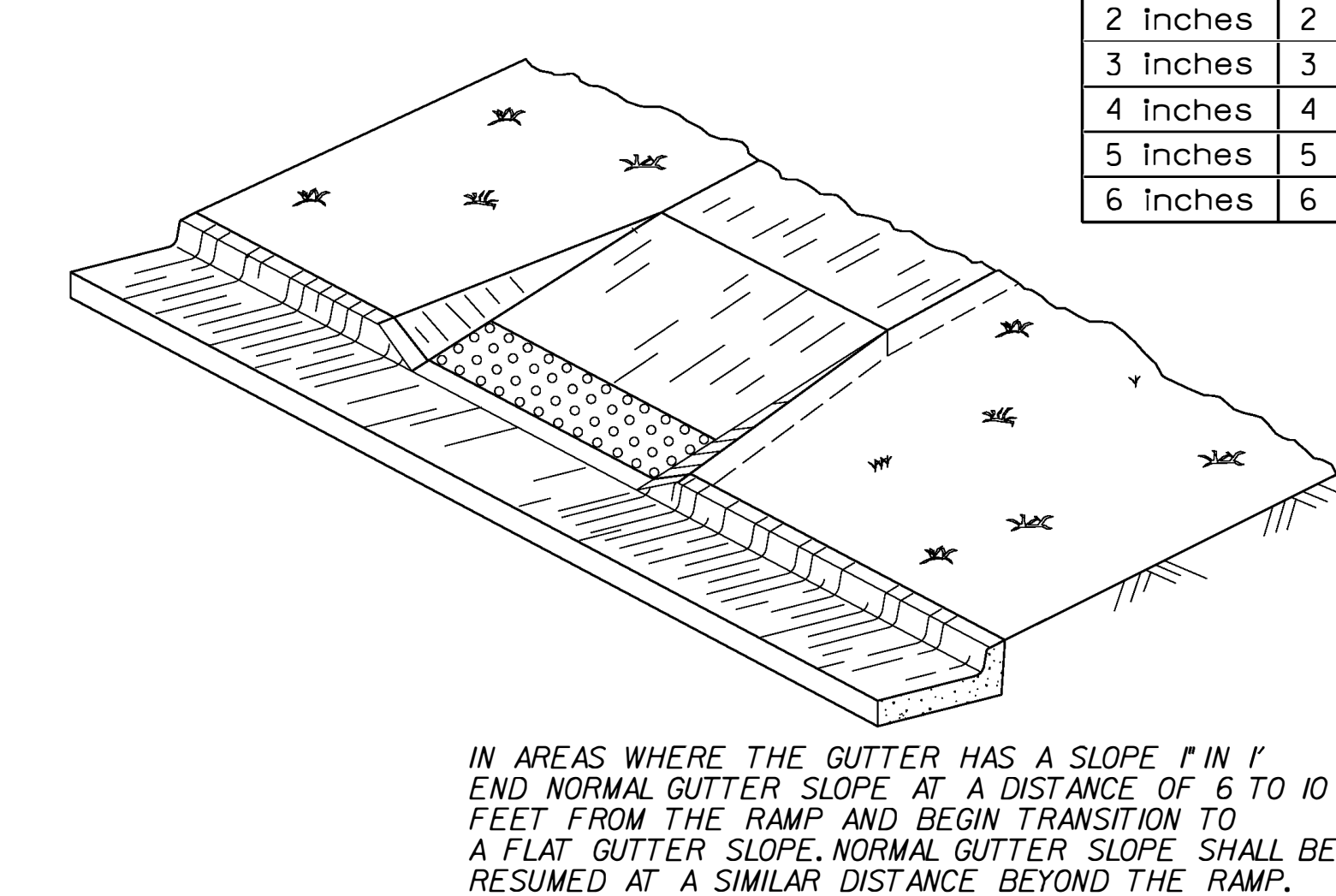
Type B

(Normally used when space is not available for a landing at the top of a Type A Ramp)



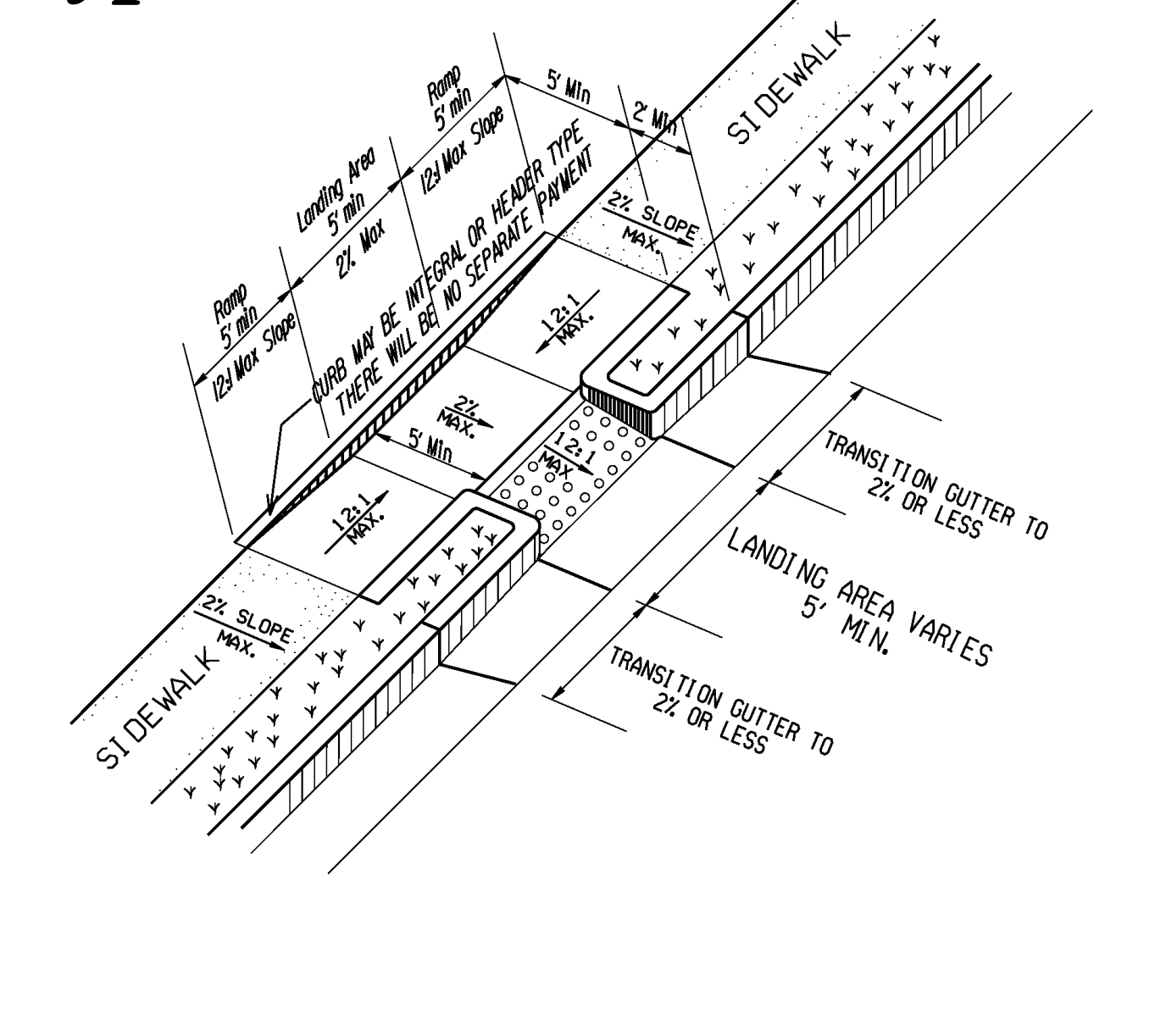
Type D

(Normally used when the sidewalk ties directly into the crosswalk)



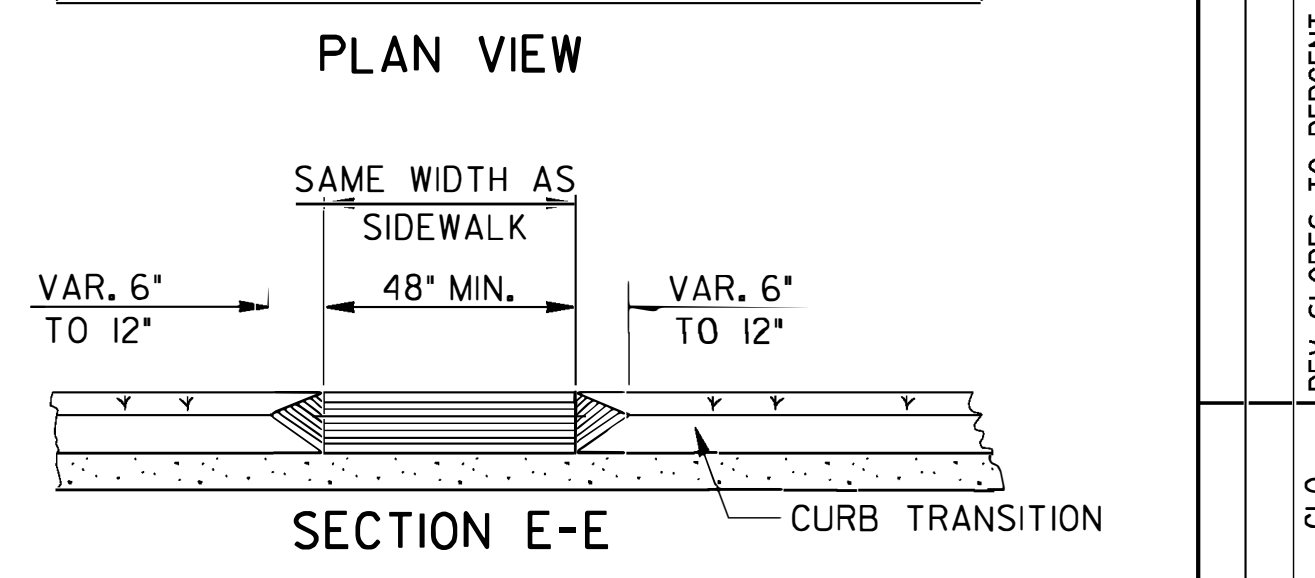
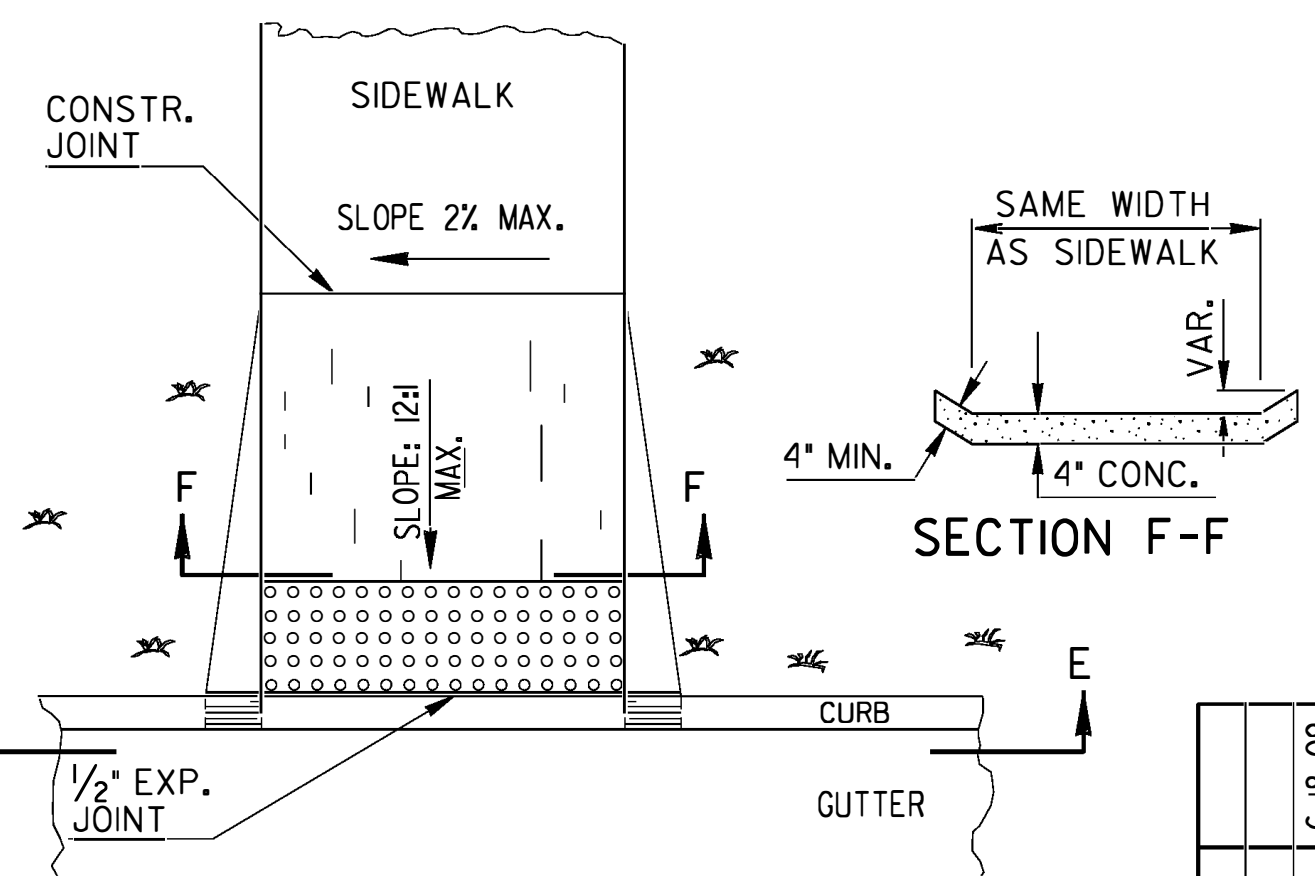
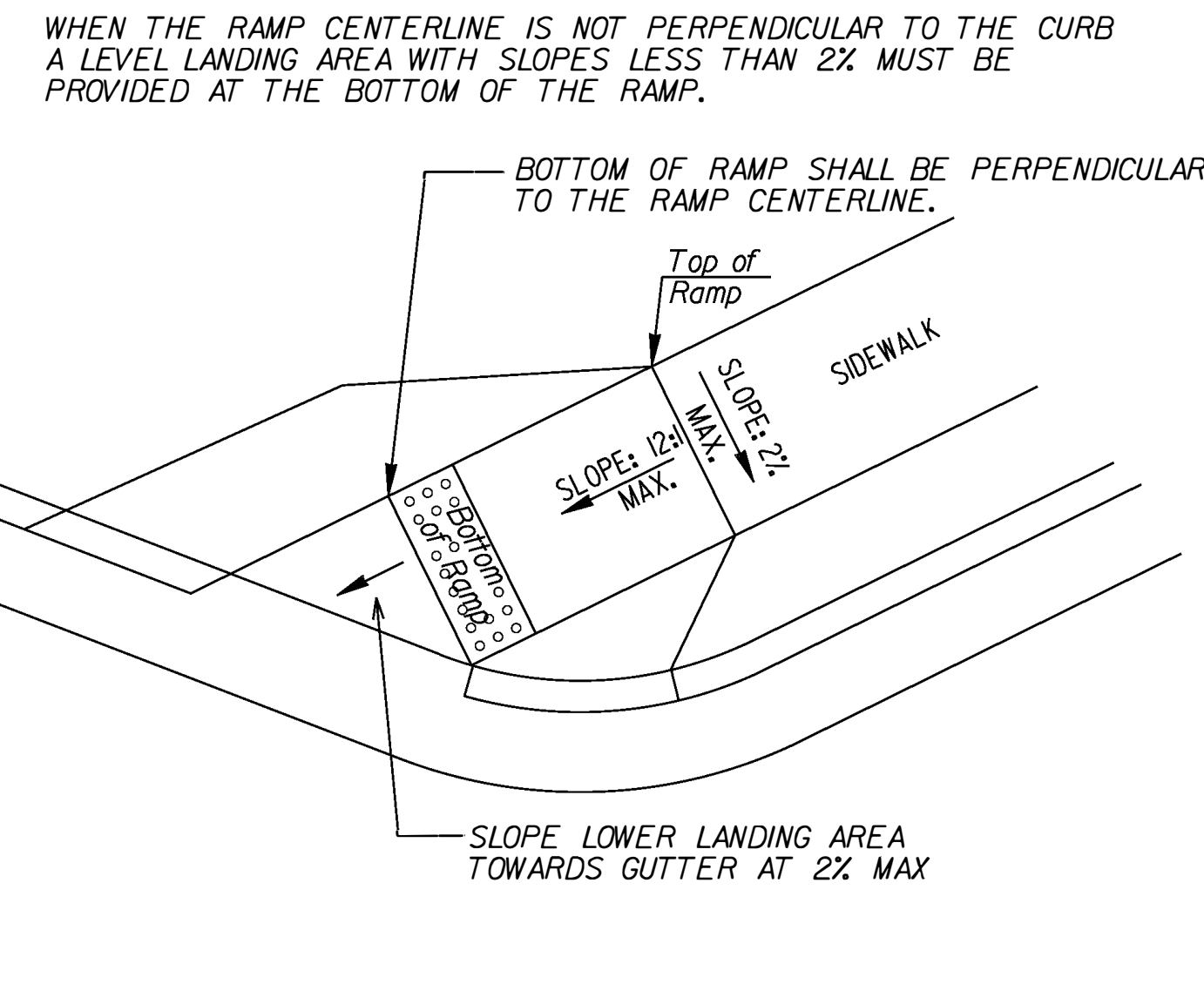
DIFFERENCE IN HEIGHT	LENGTH REQUIRED
1 inch	1 foot
2 inches	2 feet
3 inches	3 feet
4 inches	4 feet
5 inches	5 feet
6 inches	6 feet

Type C



Skewed Ramp Details

(Applies to Type A Type D Ramps Only)



This Detail Replaces Ga Standard 9031W

Guidelines For Usage On Metric Projects  
When these details are incorporated into plans and or projects that are being prepared or constructed in metric units, exact or precise conversion to metric units is not required. The dimensions shown that are in feet and inches may be converted to corresponding metric units using the following "Rounded-Off" conversion factors: 1"=25mm, 4"-100mm, and 12" or 1'-300mm. All measurement notes that refer to linear feet and square yards shall be interpreted to mean linear meters and square meters.

REV.	REV. SLOPES TO PERCENT AND ADDED GEN. NOTE NO. 8.	DATE	REVISION
6-18-09			
GLO	REV. SLOPES TO PERCENT AND ADDED GEN. NOTE NO. 8.	5-10-06	
GLO	REV. TRUNCATED DOMES	2-21-03	
		2-10-03	
		7-29-02	
		5-23-02	
		5-13-02	
		4-29-02	
		4-11-02	
		4-3-02	
		3-28-02	

DEPARTMENT OF TRANSPORTATION  
STATE OF GEORGIA

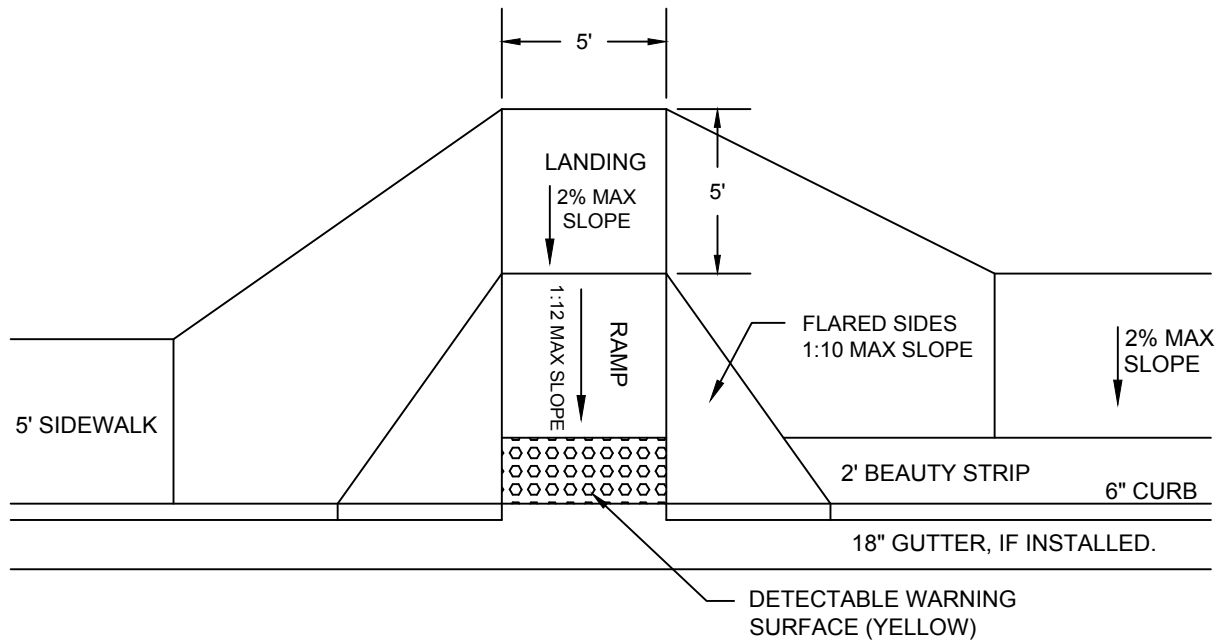
SPECIAL DETAIL  
CONCRETE SIDEWALK DETAILS  
CURB CUT (WHEELCHAIR) RAMPS

NO SCALE

MARCH 12, 2002

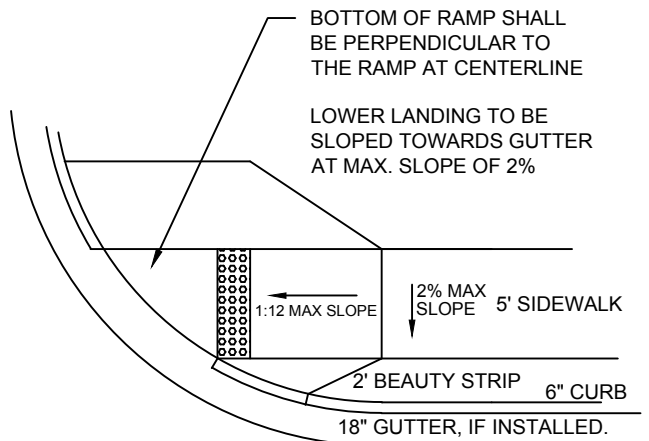
NUMBER  
**A3**

**EXHIBIT L (TASK 1)  
SPECIFICATIONS & DETAILS FOR ADA RAMP AND TURN-DOWN SIDEWALK**



**GENERAL NOTES:**

1. RAMP SHALL BE CONSTRUCTED FROM CONCRETE. SPECIFICATIONS FOR RAMP SHALL BE THE SAME AS FOR SIDEWALK. RAMP SHALL HAVE EITHER A ROUGH OR TEXTURED FINISH.
2. WHERE RAMP ARE LOCATED ON RADII, THE DIMENSIONS SHOWN FOR RAMP WIDTHS AND TAPERS ARE MEASURED PERPENDICULAR TO THE RAMP AND NOT ALONG THE CURVE.
3. WHERE UTILITY STRUCTURES CONFLICT, THERE SIDEWALK GEOMETRY VARIES, AT SKEWED INTERSECTIONS, OR IN OTHER SPECIAL CASES, THE RAMP DESIGNS MAY BE MODIFIED BY THE DESIGNER OR ENGINEER, PROVIDED THAT THE WIDTH REMAINS A MIN. OF 48" AND NO SLOPE ON THE ACCESSIBLE PART OF THE RAMP IS STEEPER THAT 12:1.
4. WHEN A CURB RAMP IS PLACED ON EXISTING PAVEMENT, THE PAVEMENT SHALL BE REMOVED TO PROVIDE A MINIMUM THICKNESS OF 3" OF CONCRETE AT ALL LOCATIONS.
5. DETECTABLE WARNING SURFACES ARE REQUIRED ON ALL INTERSECTIONS WITH PUBLIC STREETS, SIGNALIZED COMMERCIAL DRIVEWAYS, AND COMMERCIAL DRIVEWAYS WITH AN AADT OF 25 VPD.
6. REFERENCE SHOULD BE MADE TO GDOT STANDARD A3, SPECIAL DETAIL CONCRETE SIDEWALK DETAILS, CURB CUT (WHEELCHAIR) RAMPS AND GDOT STANDARD A4, SPECIAL DETAIL DETECTABLE WARNING SURFACE TRUNCATED DOME SIZE, SPACING AND ALIGNMENT REQUIREMENTS.



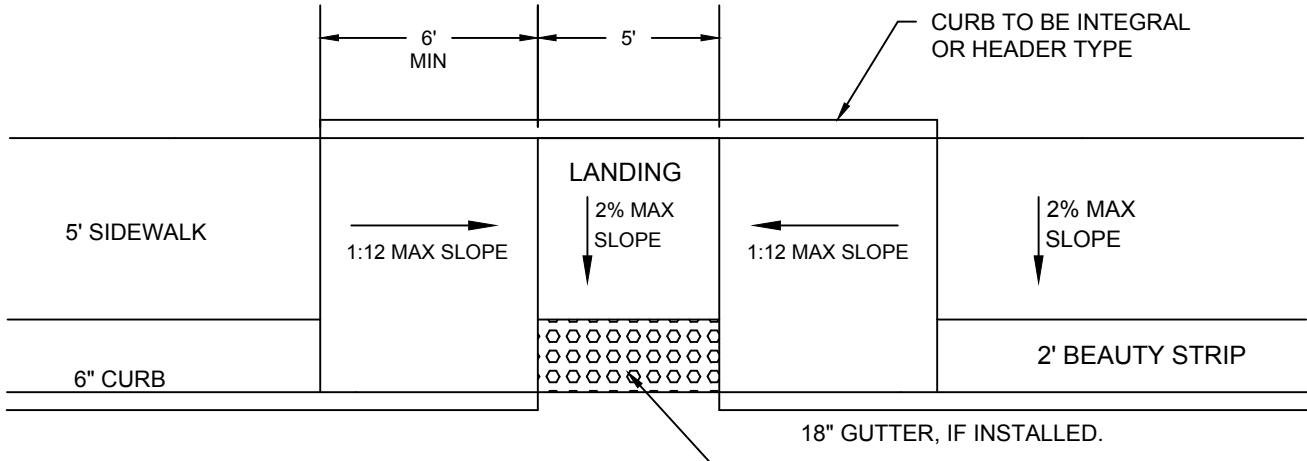
SKEWED RAMP DETAIL  
TYPE "A" AND "D" RAMPS ONLY

NOT TO SCALE

**CITY OF BROOKHAVEN  
PUBLIC WORKS DEPARTMENT  
HANDICAP RAMP  
TYPE "A"**



**EXHIBIT L (TASK 1)  
SPECIFICATIONS & DETAILS FOR ADA RAMP AND TURN-DOWN SIDEWALK**



NOTE:  
WHERE SIDEWALK ABUTS BACK OF CURB  
LANDING AREA MAY BE REDUCED TO 3' MIN  
DEPTH BEHIND DETECTABLE WARNING SURFACE.

DETECTABLE WARNING  
SURFACE (YELLOW)

**GENERAL NOTES:**

1. RAMPS SHALL BE CONSTRUCTED FROM CONCRETE. SPECIFICATIONS FOR RAMPS SHALL BE THE SAME AS FOR SIDEWALK. RAMPS SHALL HAVE EITHER A ROUGH OR TEXTURED FINISH.
2. WHERE RAMPS ARE LOCATED ON RADII, THE DIMENSIONS SHOWN FOR RAMP WIDTHS AND TAPERS ARE MEASURED PERPENDICULAR TO THE RAMP AND NOT ALONG THE CURVE.
3. WHERE UTILITY STRUCTURES CONFLICT, THERE SIDEWALK GEOMETRY VARIES, AT SKEWED INTERSECTIONS, OR IN OTHER SPECIAL CASES, THE RAMP DESIGNS MAY BE MODIFIED BY THE DESIGNER OR ENGINEER, PROVIDED THAT THE WIDTH REMAINS A MIN. OF 48" AND NO SLOPE ON THE ACCESSIBLE PART OF THE RAMP IS STEEPER THAT 12:1.
4. WHEN A CURB RAMP IS PLACED ON EXISTING PAVEMENT, THE PAVEMENT SHALL BE REMOVED TO PROVIDE A MINIMUM THICKNESS OF 3" OF CONCRETE AT ALL LOCATIONS.
5. DETECTABLE WARNING SURFACES ARE REQUIRED ON ALL INTERSECTIONS WITH PUBLIC STREETS, SIGNALIZED COMMERCIAL DRIVEWAYS, AND COMMERCIAL DRIVEWAYS WITH AN AADT OF 25 VPD.
6. REFERENCE SHOULD BE MADE TO GDOT STANDARD A3, SPECIAL DETAIL CONCRETE SIDEWALK DETAILS, CURB CUT (WHEELCHAIR) RAMPS AND GDOT STANDARD A4, SPECIAL DETAIL DETECTABLE WARNING SURFACE TRUNCATED DOME SIZE, SPACING AND ALIGNMENT REQUIREMENTS.

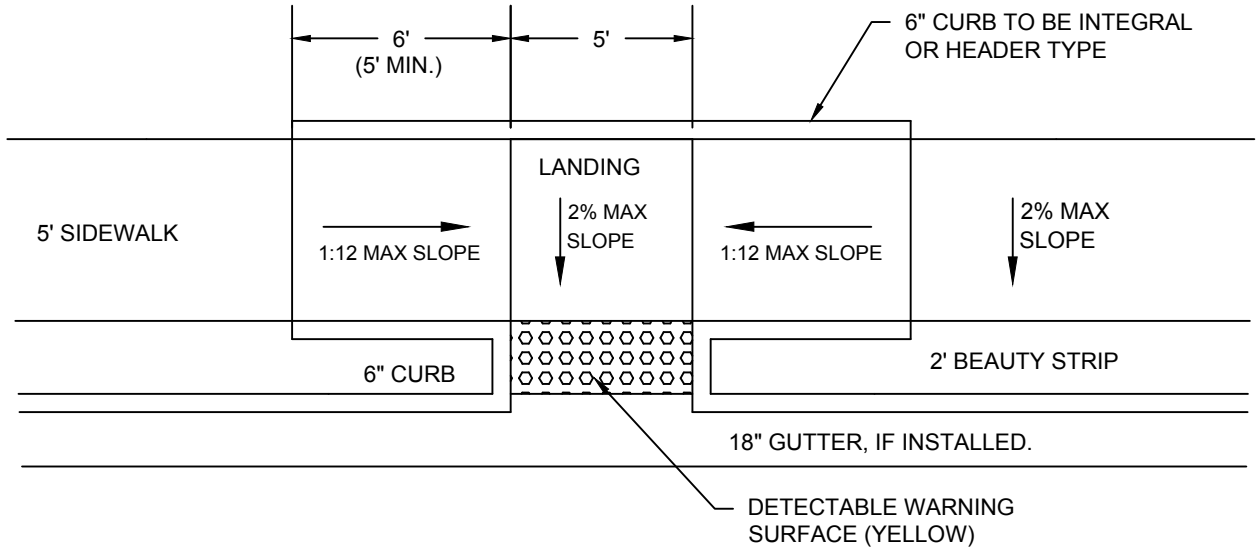
NOT TO SCALE

**CITY OF BROOKHAVEN  
PUBLIC WORKS DEPARTMENT  
HANDICAP RAMP  
TYPE "B"**



APRIL 2019

**EXHIBIT L (TASK 1)  
SPECIFICATIONS & DETAILS FOR ADA RAMP AND TURN-DOWN SIDEWALK**



**GENERAL NOTES:**

1. RAMPS SHALL BE CONSTRUCTED FROM CONCRETE. SPECIFICATIONS FOR RAMPS SHALL BE THE SAME AS FOR SIDEWALK. RAMPS SHALL HAVE EITHER A ROUGH OR TEXTURED FINISH.
2. WHERE RAMPS ARE LOCATED ON RADII, THE DIMENSIONS SHOWN FOR RAMP WIDTHS AND TAPERS ARE MEASURED PERPENDICULAR TO THE RAMP AND NOT ALONG THE CURVE.
3. WHERE UTILITY STRUCTURES CONFLICT, THERE SIDEWALK GEOMETRY VARIES, AT SKEWED INTERSECTIONS, OR IN OTHER SPECIAL CASES, THE RAMP DESIGNS MAY BE MODIFIED BY THE DESIGNER OR ENGINEER, PROVIDED THAT THE WIDTH REMAINS A MIN. OF 48" AND NO SLOPE ON THE ACCESSIBLE PART OF THE RAMP IS STEEPER THAT 12:1.
4. WHEN A CURB RAMP IS PLACED ON EXISTING PAVEMENT, THE PAVEMENT SHALL BE REMOVED TO PROVIDE A MINIMUM THICKNESS OF 3" OF CONCRETE AT ALL LOCATIONS.
5. DETECTABLE WARNING SURFACES ARE REQUIRED ON ALL INTERSECTIONS WITH PUBLIC STREETS, SIGNALIZED COMMERCIAL DRIVEWAYS, AND COMMERCIAL DRIVEWAYS WITH AN AADT OF 25 VPD.
6. REFERENCE SHOULD BE MADE TO GDOT STANDARD A3, SPECIAL DETAIL CONCRETE SIDEWALK DETAILS, CURB CUT (WHEELCHAIR) RAMPS AND GDOT STANDARD A4, SPECIAL DETAIL DETECTABLE WARNING SURFACE TRUNCATED DOME SIZE, SPACING AND ALIGNMENT REQUIREMENTS.

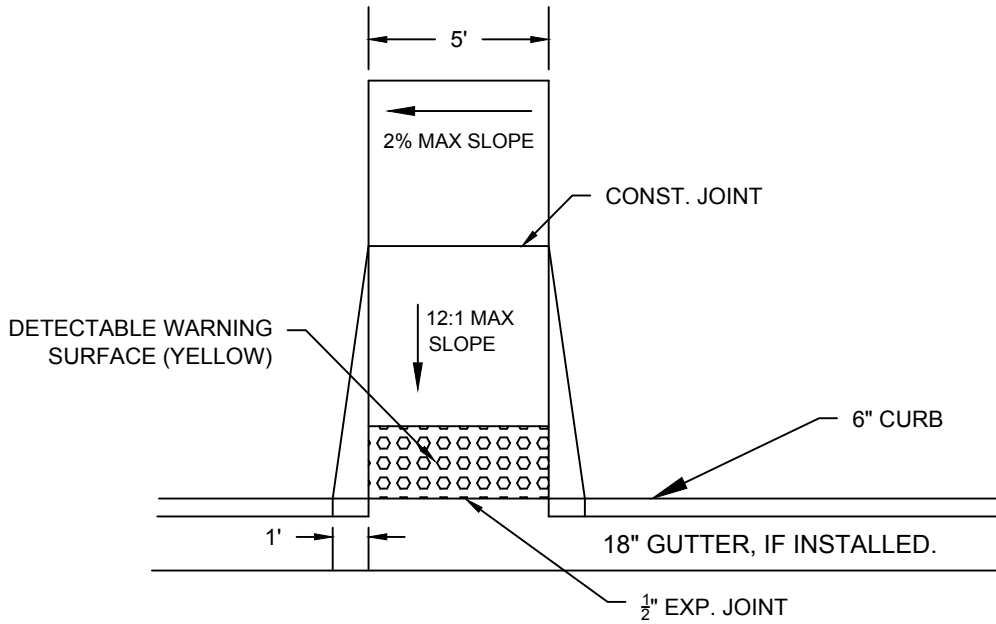
NOT TO SCALE

**CITY OF BROOKHAVEN  
PUBLIC WORKS DEPARTMENT  
HANDICAP RAMP  
TYPE "C"  
PARALLEL ALIGNMENT**



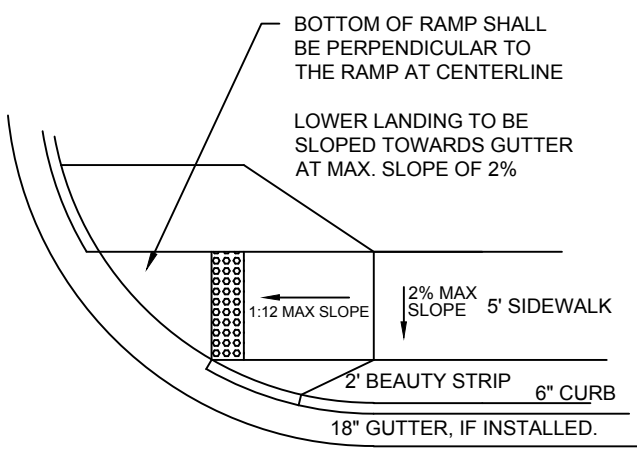
APRIL 2019

**EXHIBIT L (TASK 1)  
SPECIFICATIONS & DETAILS FOR ADA RAMP AND TURN-DOWN SIDEWALK**



**GENERAL NOTES:**

1. RAMPS SHALL BE CONSTRUCTED FROM CONCRETE. SPECIFICATIONS FOR RAMPS SHALL BE THE SAME AS FOR SIDEWALK. RAMPS SHALL HAVE EITHER A ROUGH OR TEXTURED FINISH.
2. WHERE RAMPS ARE LOCATED ON RADII, THE DIMENSIONS SHOWN FOR RAMP WIDTHS AND TAPERS ARE MEASURED PERPENDICULAR TO THE RAMP AND NOT ALONG THE CURVE.
3. WHERE UTILITY STRUCTURES CONFLICT, THERE SIDEWALK GEOMETRY VARIES, AT SKEWED INTERSECTIONS, OR IN OTHER SPECIAL CASES, THE RAMP DESIGNS MAY BE MODIFIED BY THE DESIGNER OR ENGINEER, PROVIDED THAT THE WIDTH REMAINS A MIN. OF 48" AND NO SLOPE ON THE ACCESSIBLE PART OF THE RAMP IS STEEPER THAT 12:1.
4. WHEN A CURB RAMP IS PLACED ON EXISTING PAVEMENT, THE PAVEMENT SHALL BE REMOVED TO PROVIDE A MINIMUM THICKNESS OF 3" OF CONCRETE AT ALL LOCATIONS.
5. DETECTABLE WARNING SURFACES ARE REQUIRED ON ALL INTERSECTIONS WITH PUBLIC STREETS, SIGNALIZED COMMERCIAL DRIVEWAYS, AND COMMERCIAL DRIVEWAYS WITH AN AADT OF 25 VPD.
6. REFERENCE SHOULD BE MADE TO GDOT STANDARD A3, SPECIAL DETAIL CONCRETE SIDEWALK DETAILS, CURB CUT (WHEELCHAIR) RAMPS AND GDOT STANDARD A4, SPECIAL DETAIL DETECTABLE WARNING SURFACE TRUNCATED DOME SIZE, SPACING AND ALIGNMENT REQUIREMENTS.



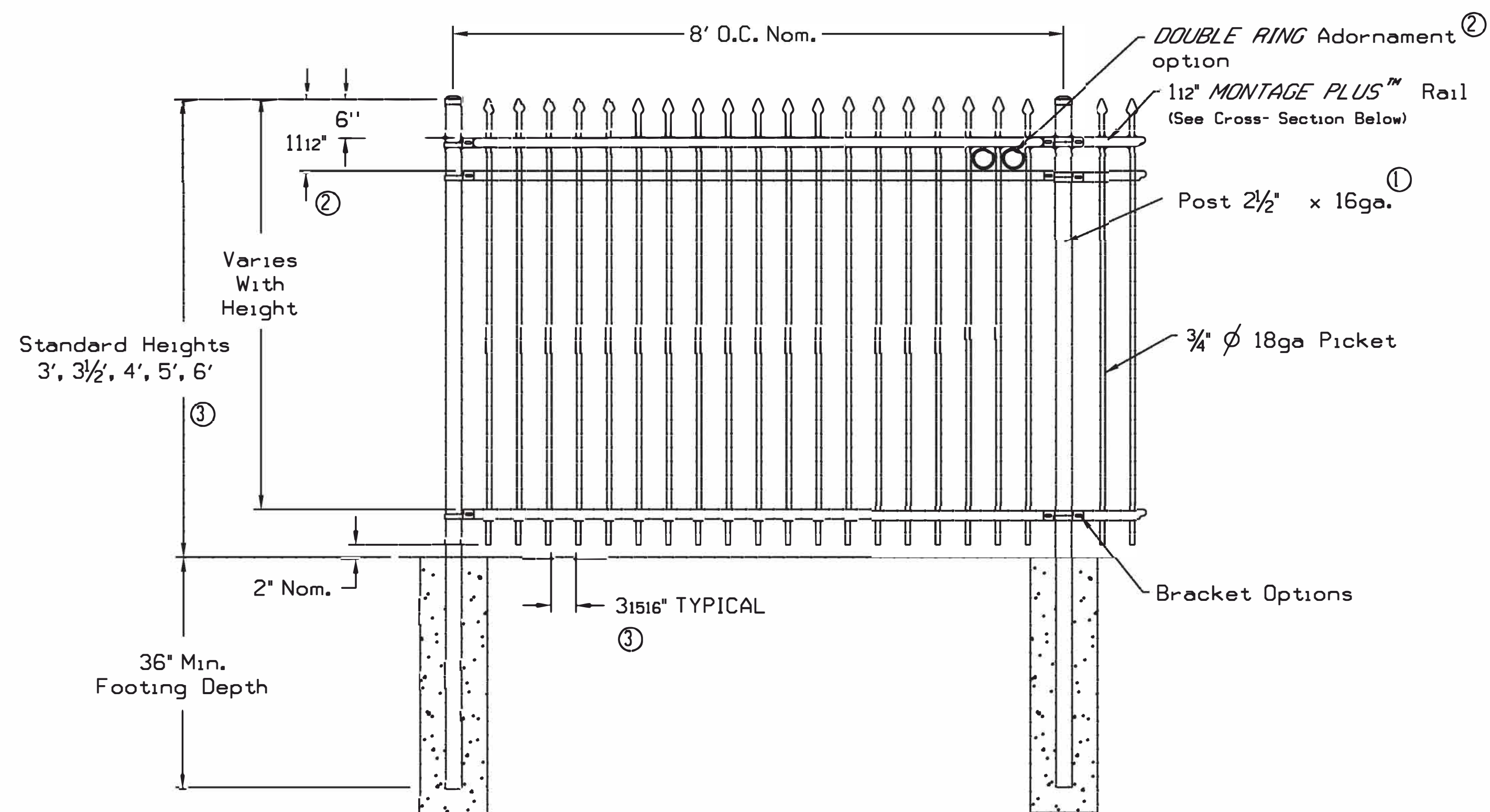
SKEWED RAMP DETAIL  
TYPE "A" AND "D" RAMPS ONLY

NOT TO SCALE

**CITY OF BROOKHAVEN  
PUBLIC WORKS DEPARTMENT  
HANDICAP RAMP  
TYPE "D"**



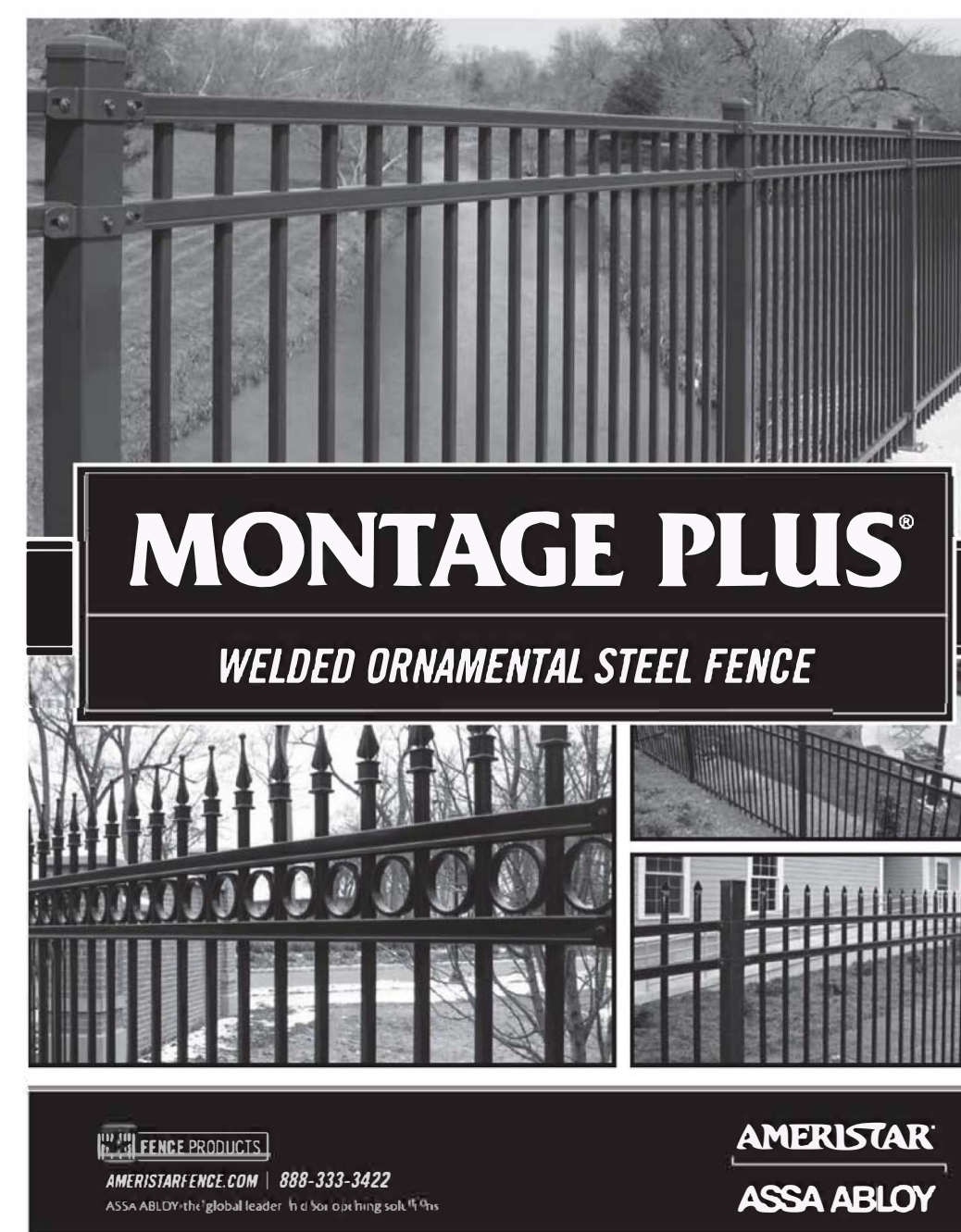
APRIL 2019



NOTES:

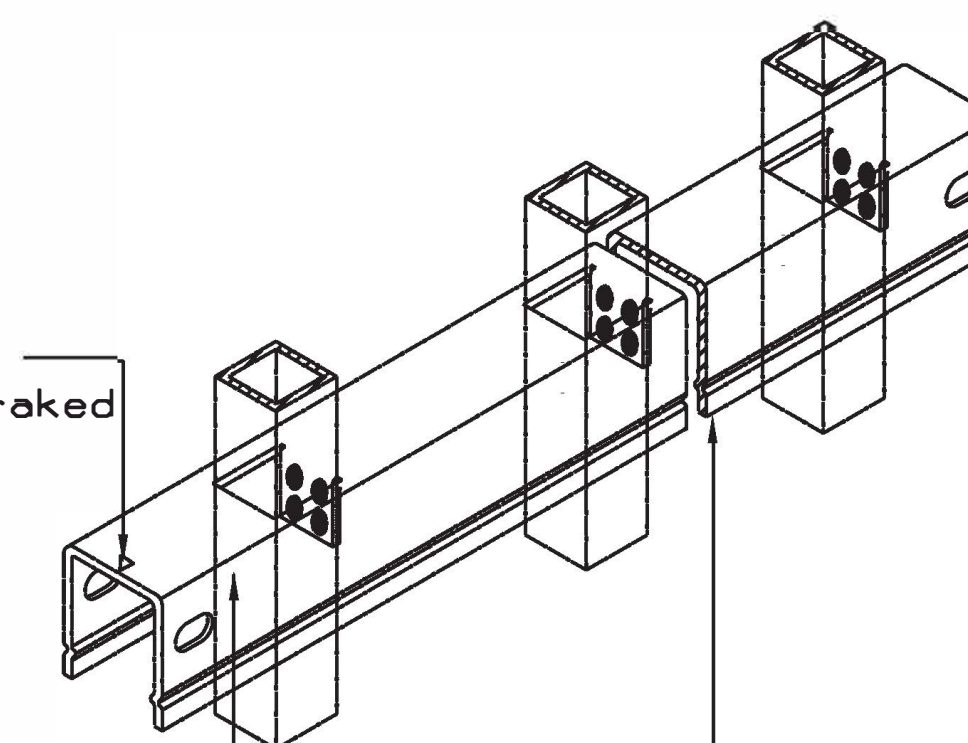
- 1.) Post size depends on fence height and wind loads. See *MONTAGE PLUS™* specifications for post sizing chart.
- 2.) Third rail required for *Double Rings*
- 3.) Available in 3" air space and/or Flush Bottom on most heights.

Values shown are nominal and not to be used for installation purposes. See product specification for installation requirements.



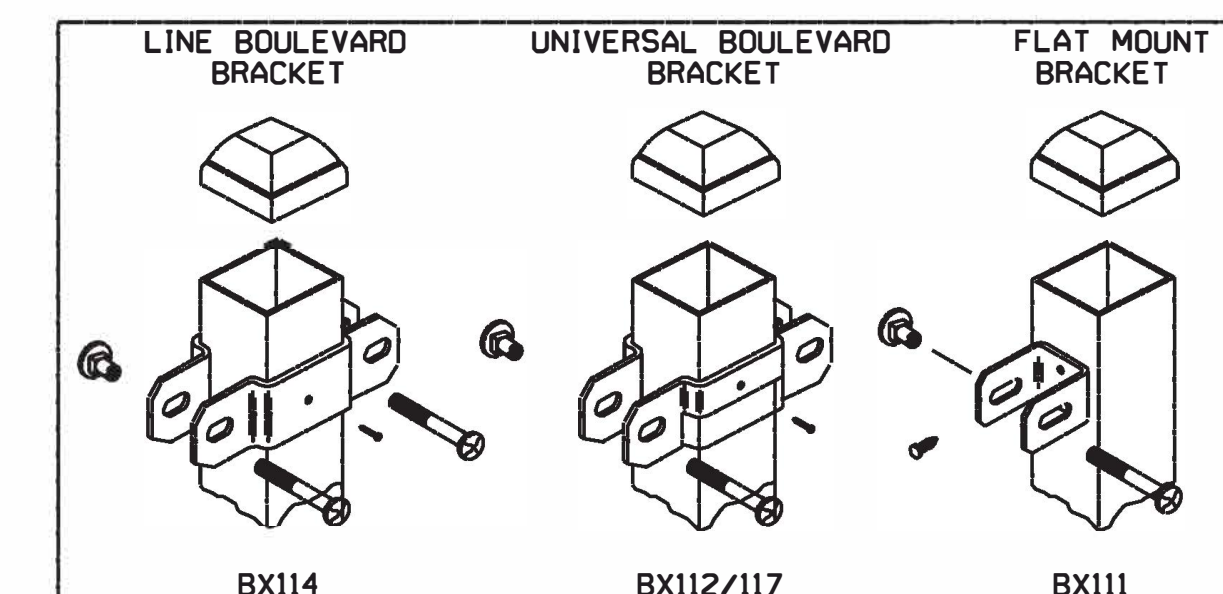
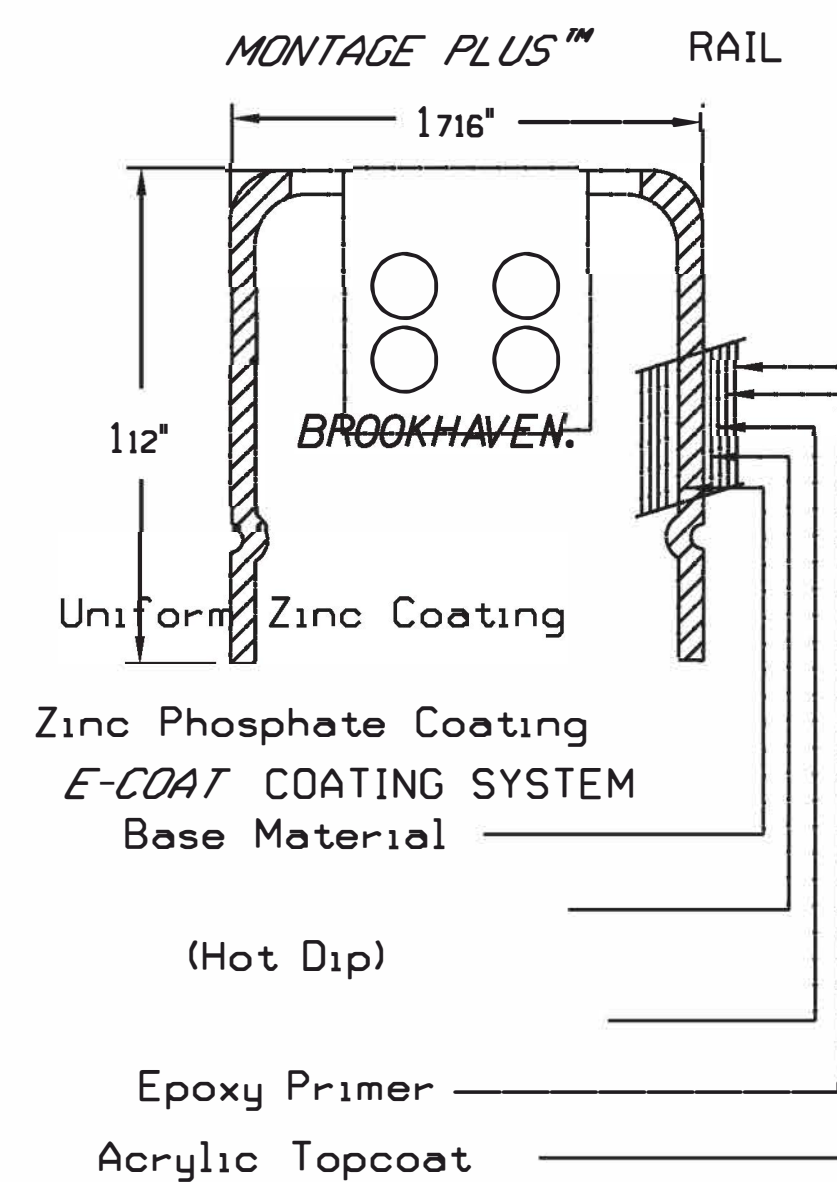
NOTE: STYLE AND PANEL OPTION AT THE DISCRETION OF THE CITY OF BROOKHAVEN. AN EQUIVALENT PRODUCT MAY BE SUBMITTED FOR APPROVAL BY THE ENGINEER.

RAKING DIRECTIONAL ARROW  
Welded panel can be raked 30° over 8' with arrow pointing down grade.



PROFUSION™ WELDING PROCESS  
No exposed welds, Good Neighbor profile - Same appearance on both sides

MONTAGE PLUS™ RAIL  
Specially formed high strength architectural shape.



SPECIAL DESIGN DECORATIVE FENCE



REVISION DATES

NO.	DATE	DESCRIPTION

SPECIAL CONSTRUCTION DETAIL

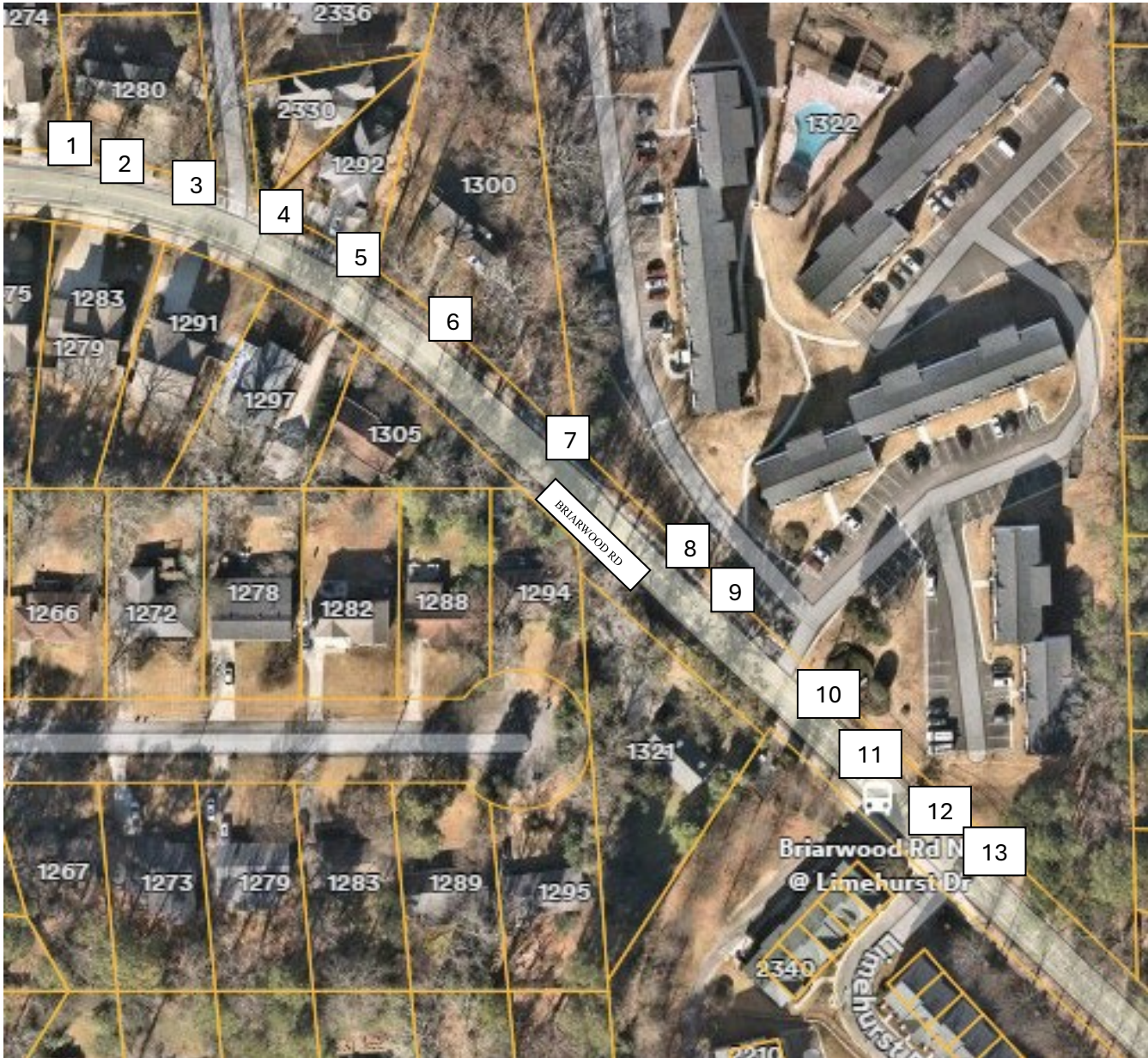
CHECKED:	DATE:	DRAWING No.
BACKCHECKED:	DATE:	38-0001
CORRECTED:	DATE:	
VERIFIED:	DATE:	

**EXHIBIT M (TASK 2)**  
**SPECIFICATIONS, LOCATIONS & DETAILS FOR ADA RAMP/SIDEWALK REPAIR/REPLACE**

**Description: TASK 2**

Task 2 is a simple repair or removal and replacement of ramps and interconnecting sidewalks to ADA (Americans with Disabilities) Standards. The bulk of the work is the removal and replacement of broken and unsafe sidewalk sections with a few ADA ramp replacements, which relate to the GADOT Special Detail A3 Special Detail Concrete Sidewalk & Curb Cut (Wheelchair) Ramps, found in this section. The Bid Sheet for this task is in Exhibit K of this document. Locations of work for Task 2 are included in *Figure 2*, below.

*Figure 1: Map Identifying Work Locations 1-13.*



**EXHIBIT M (TASK 2)**  
**SPECIFICATIONS, LOCATIONS & DETAILS FOR ADA RAMP/SIDEWALK REPAIR/REPLACE**

Figure 2: Map Identifying Work Locations 14.1 – 15.3.





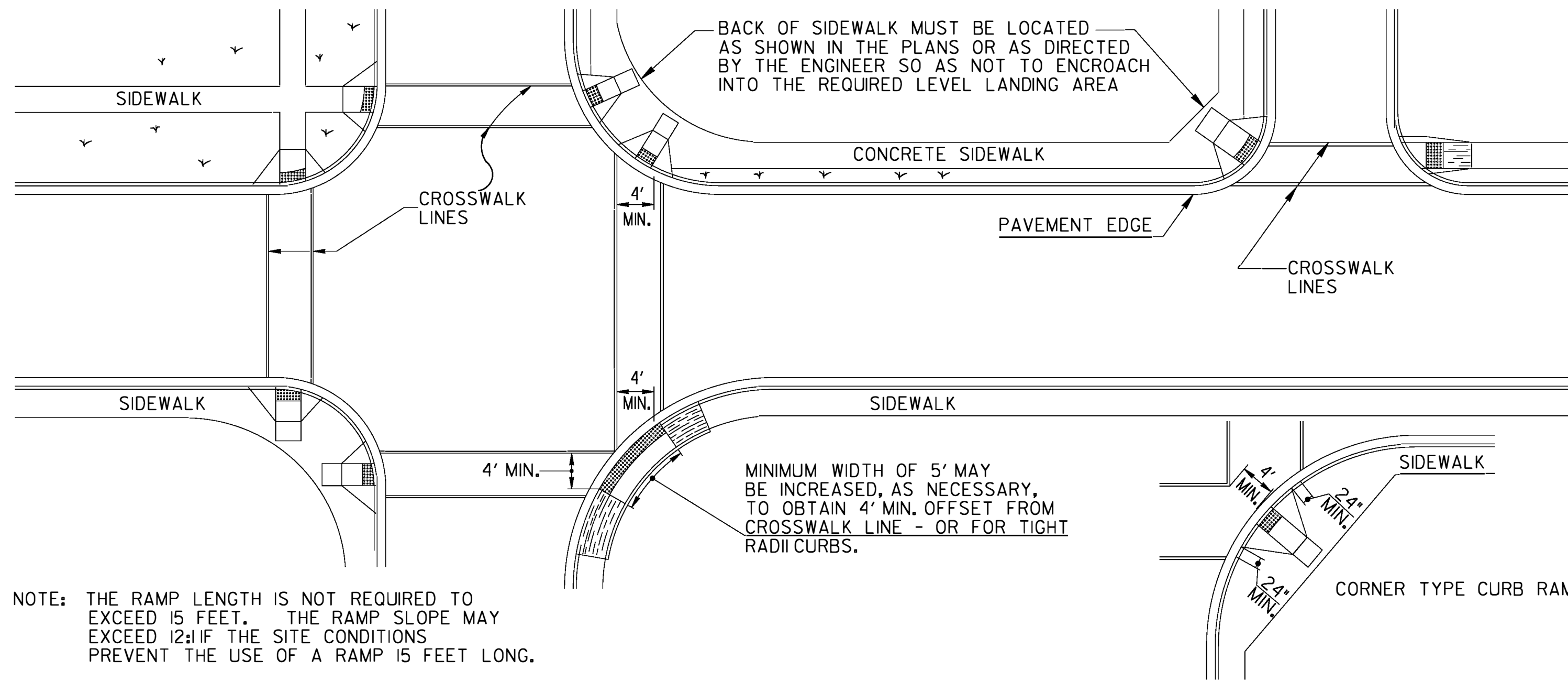
**EXHIBIT M (TASK 2)**  
**SPECIFICATIONS, LOCATIONS & DETAILS FOR ADA RAMP/SIDEWALK REPAIR/REPLACE**

Figure 3: Map Identifying Work Locations 16.1 – 16.17.

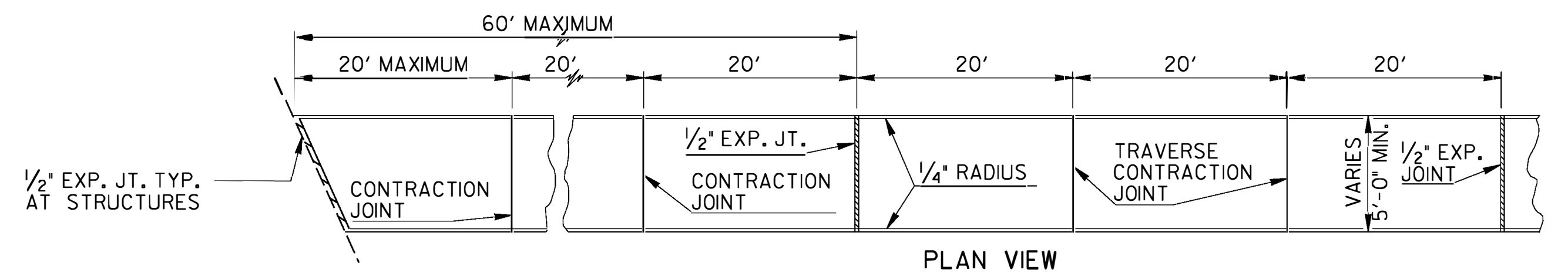


STATE	PROJECT NUMBER	SHEET NO.	TOTAL SHEETS
GA.	STP00-2868-00(00)	113	258

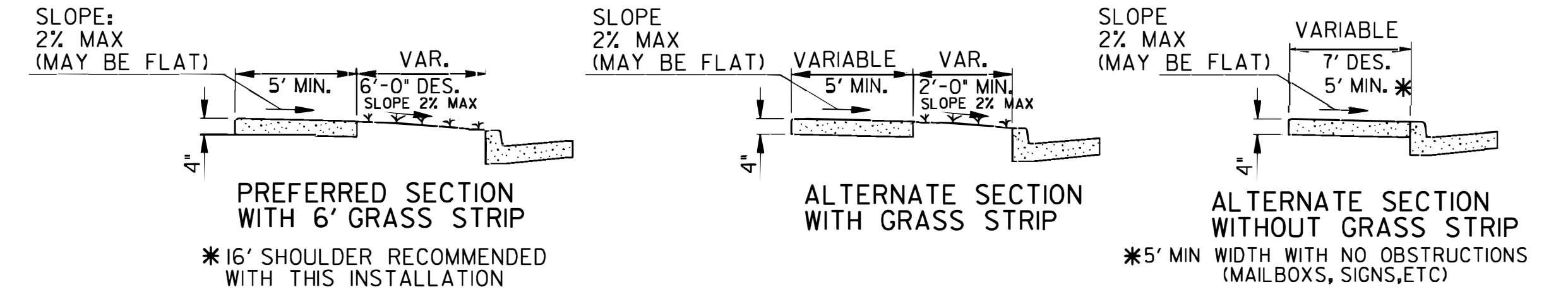
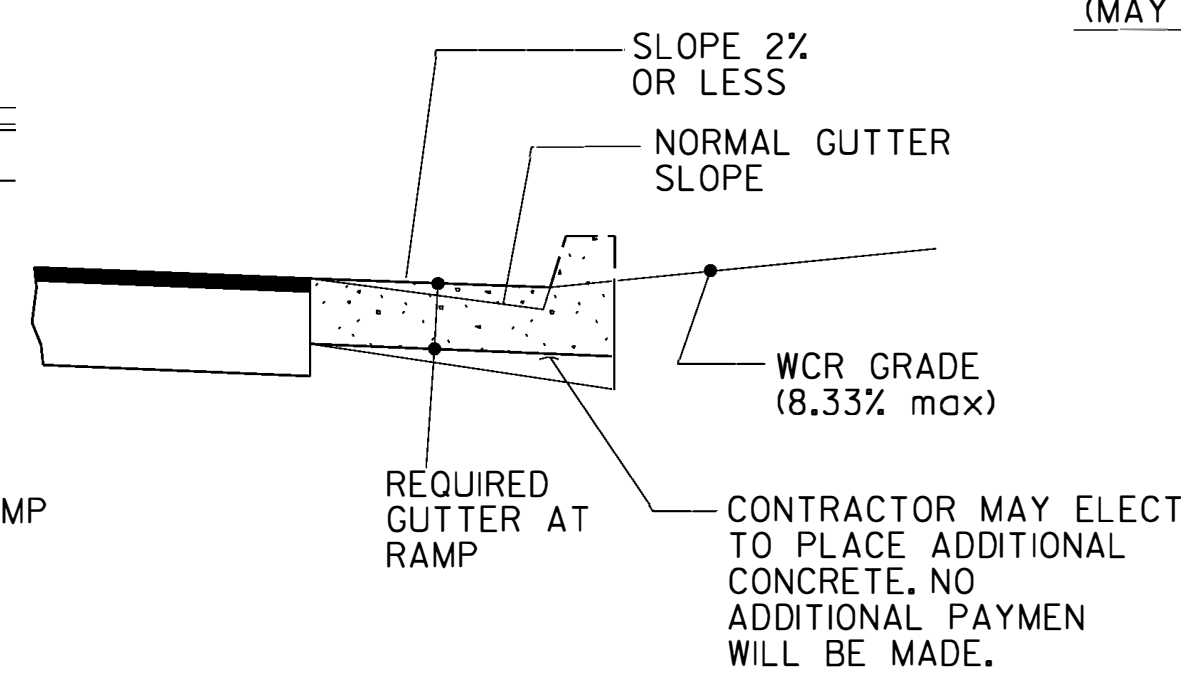
TYPICAL LOCATIONS FOR CURB CUT RAMPS - PLAN VIEW



CONCRETE SIDEWALK DETAILS



GUTTER TRANSITION DETAIL



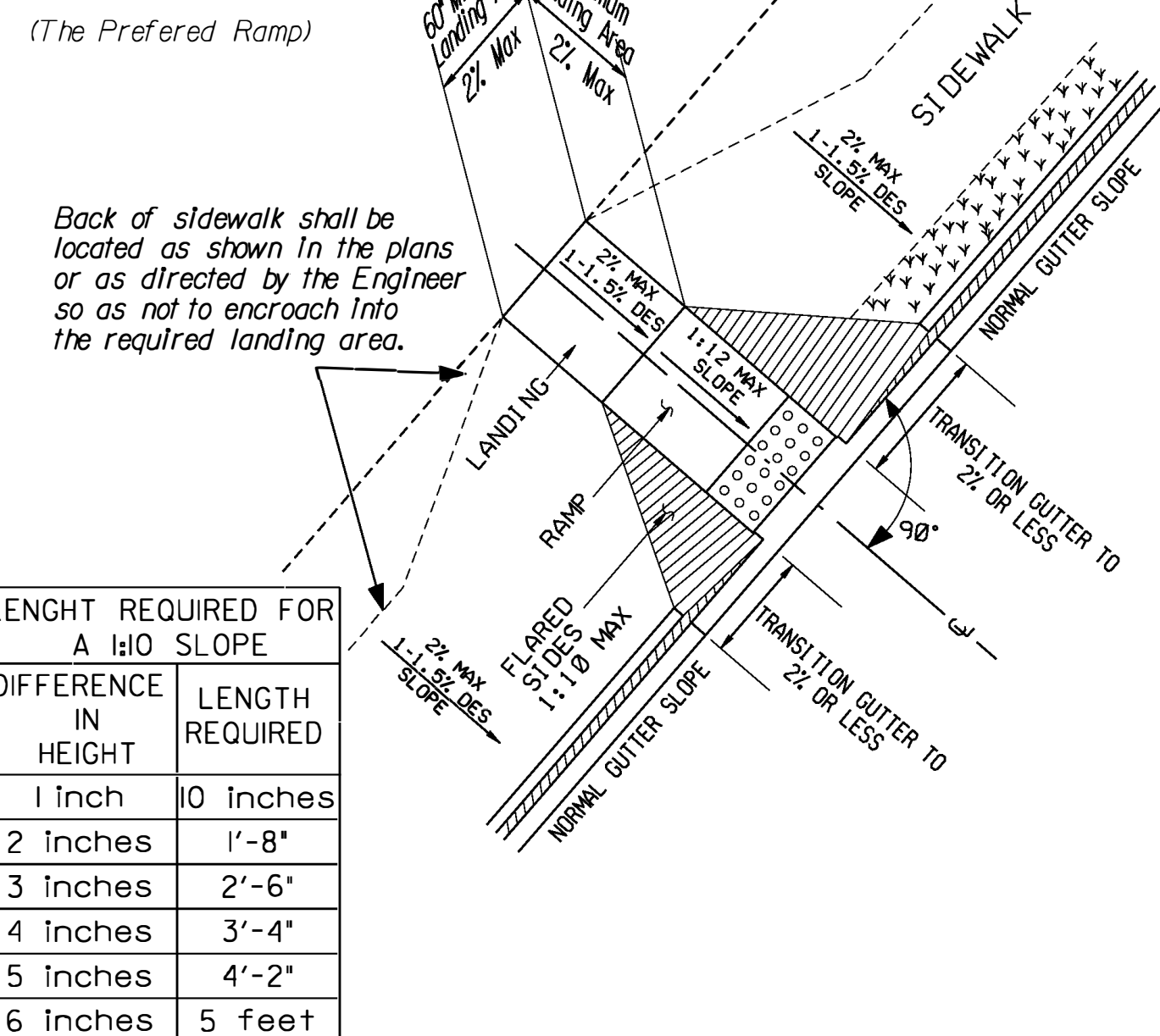
NOTES FOR CONCRETE SIDEWALK:

- CONCRETE TO BE PLACED 4" THICK AND FINISHED WITH TAMPS, WOOD FLOATS AND STIFF-BRISTLE BROOMS.
- TRANSVERSE CONTRACTION JOINTS SHALL BE PLACED AT 20 FT. INTERVALS. ALL EDGES TO BE ROUNDED TO 1/4" RADIUS.
- 1/2" EXPANSION JOINTS SHALL BE PLACED, WHERE SIDEWALK TIE INTO A STRUCTURE OR TERMINATE AT CURB, RAMPS OR DRIVEWAYS AND AT 60' INTERVALS.

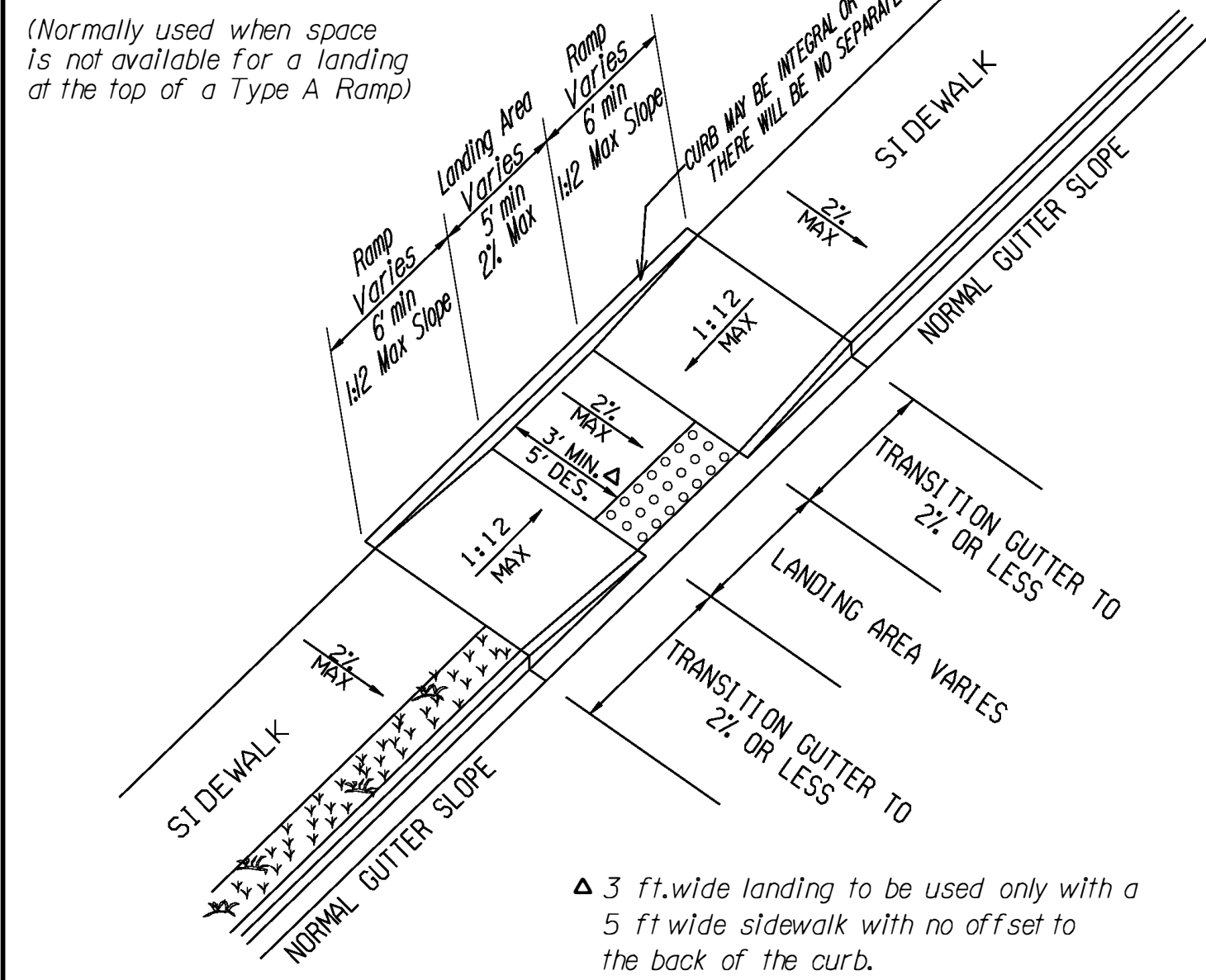
NOTES FOR CURB CUT RAMPS:

- CURB CUT RAMPS WILL BE LOCATED AS FOLLOWS UNLESS PLANS OR CONTRACT SPECIFY OTHERWISE.
  - AT ALL PEDESTRIAN CROSSWALKS WHERE CURB IS CONSTRUCTED OR REPLACED.
  - WHERE THE SIDEWALK, CONCRETE OR UNPAVED, IS INTERRUPTED BY THE CURB AT TURNOUTS OR AT INTERSECTIONS.
  - AT OTHER LOCATIONS SUCH AS HOSPITALS, NURSING HOMES, REST AREAS, ETC., WHERE THE CURB WOULD OTHERWISE BE AN OBSTRUCTION TO THE PHYSICALLY DISABLED.
- RAMPS WILL BE CONSTRUCTED FROM CONCRETE. SPECIFICATIONS FOR RAMPS WILL BE THE SAME AS FOR CONCRETE SIDEWALK. RAMPS SHALL HAVE EITHER A ROUGH OR A TEXTURED FINISH.
- DROP INLETS ARE NOT TO BE LOCATED DIRECTLY IN FRONT OF RAMPS. CATCH BASINS SHOULD BE LOCATED AT LEAST 10 FT. FROM RAMPS WHEN FEASIBLE.
- WHERE RAMPS ARE LOCATED IN RADIUS, THE DIMENSIONS SHOWN FOR RAMP WIDTHS AND TAPERS ARE MEASURED PERPENDICULAR TO THE RAMP AND NOT ALONG THE CURVE.
- WHERE UTILITY STRUCTURES CONFLICT, WHERE SIDEWALK GEOMETRY VARIES, AT SKEWED INTERSECTIONS, OR IN OTHER SPECIAL CASES, THE RAMP DESIGNS MAY BE MODIFIED BY THE DESIGNER OR ENGINEER, PROVIDED THAT THE WIDTH REMAINS A MINIMUM OF 48 INCHES, AND NO SLOPE ON THE ACCESSIBLE PART OF THE RAMP IS STEEPER THAN 12%.
- 1 IN. FT. OF CURB AND GUTTER WILL INCLUDE THE TRANSITIONED CURB IN FRONT OF RAMPS. SO, YDS. OF CONCRETE SIDEWALK AND CONCRETE MEDIAN PAVING WILL INCLUDE RAMPS. NO ADDITIONAL PAYMENT WILL BE MADE FOR CURB RAMPS. NO ADDITIONAL PAYMENT WILL BE MADE FOR SAWING AND REMOVING EXISTING SIDEWALK OR CURB WHERE NECESSARY FOR RAMP CONSTRUCTION.
- WHEN A CURB RAMP IS PLACED ON EXISTING PAVEMENT, THE PAVEMENT SHALL BE REMOVED TO PROVIDE A MINIMUM THICKNESS OF 3 INCHES OF CONCRETE AT ALL LOCATIONS. NO SEPARATE PAYMENT WILL BE MADE FOR REMOVAL OF THE PAVEMENT.
- DETECTABLE WARNING SURFACES ARE REQUIRED ON ALL INTERSECTIONS WITH PUBLIC STREETS, SIGNALIZED COMMERCIAL DRIVEWAYS, AND COMMERCIAL DRIVEWAYS WITH AN AADT OF 25 VPD.

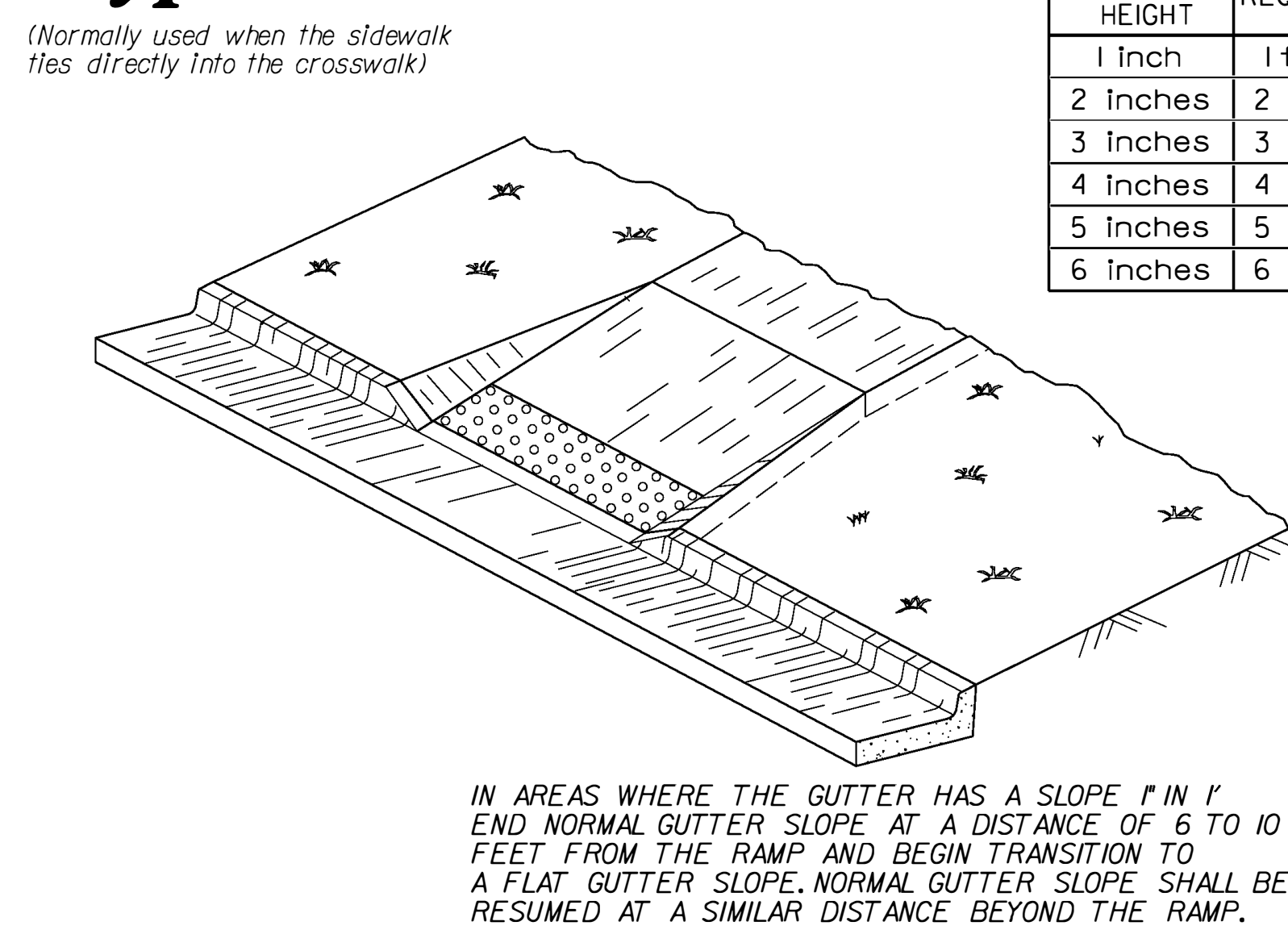
Type A



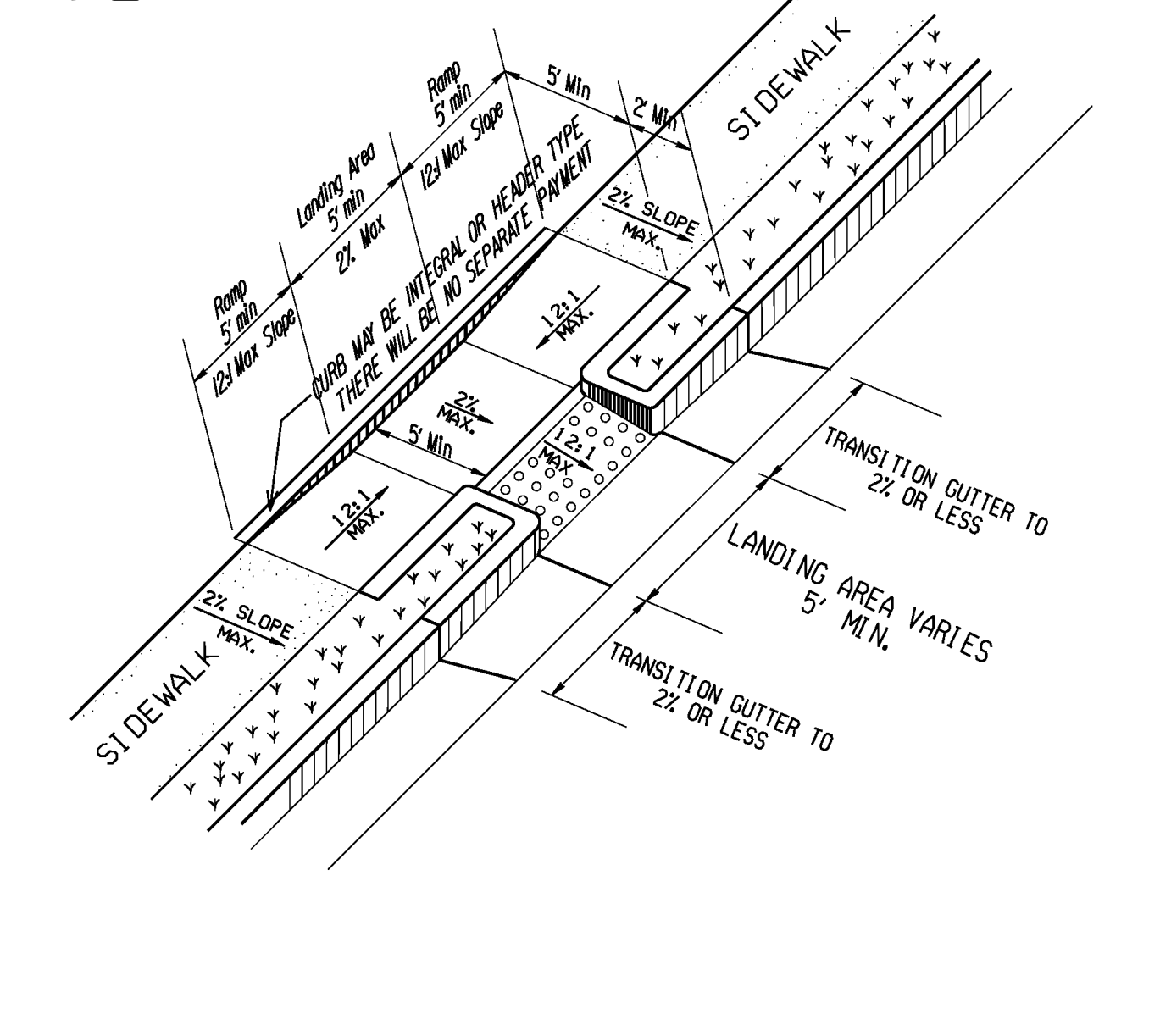
Type B



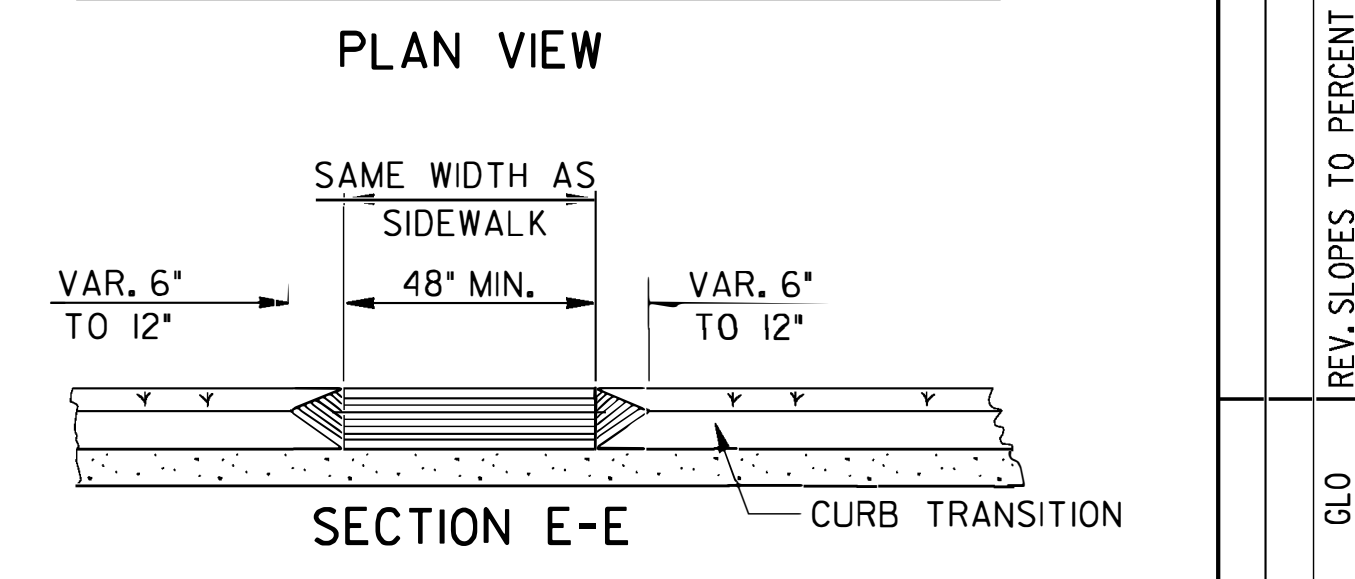
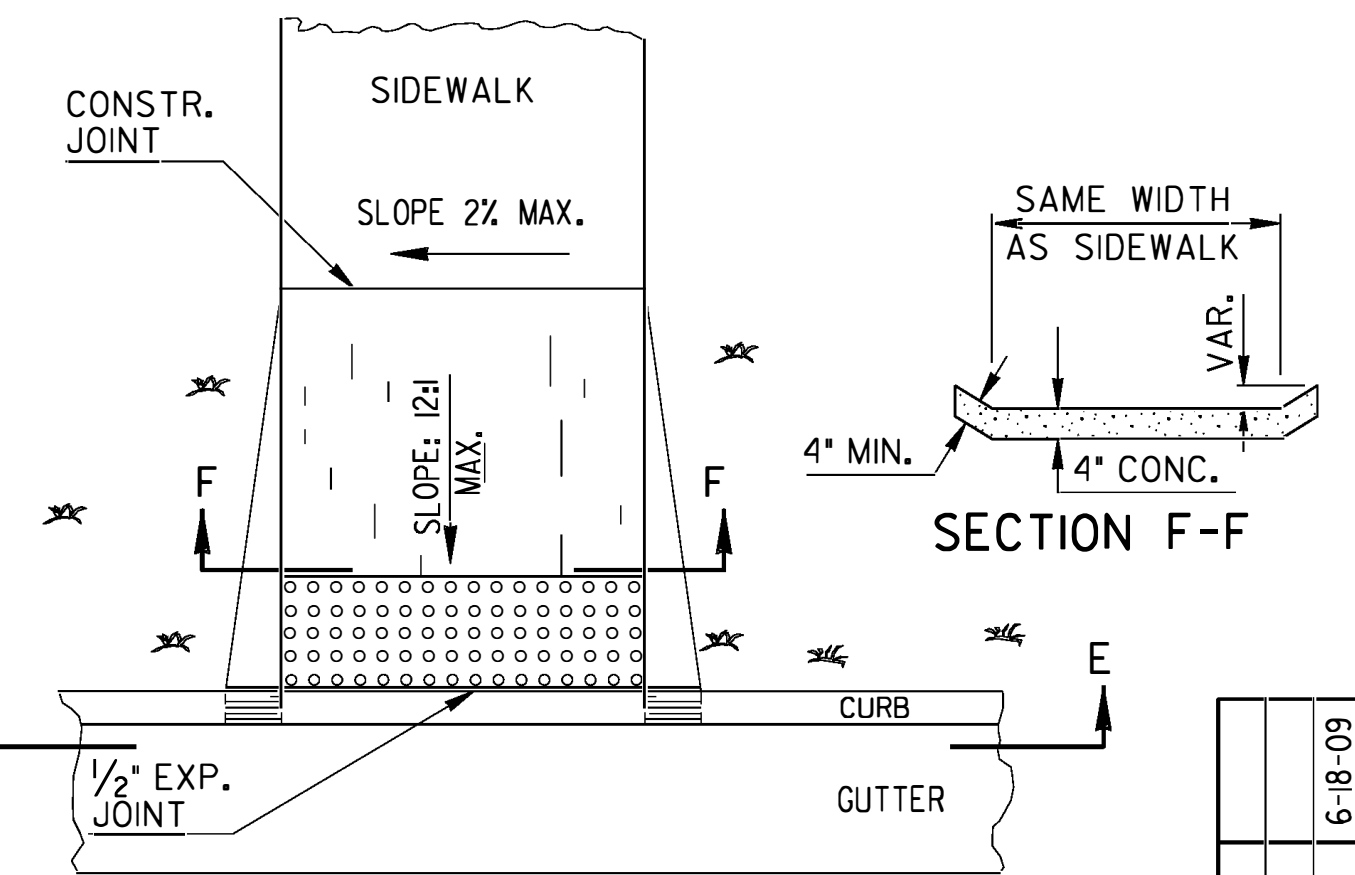
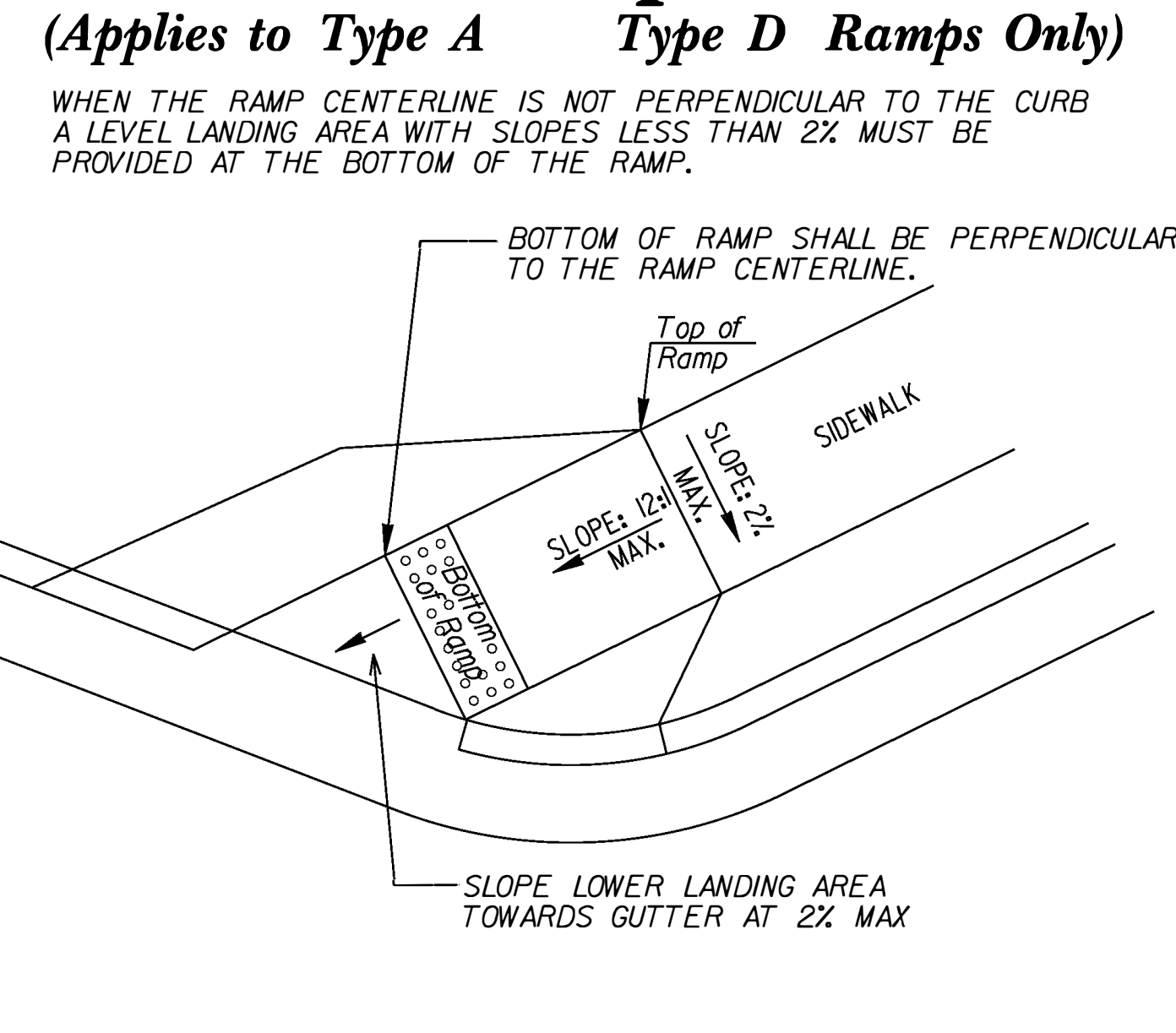
Type D



Type C



Skewed Ramp Details



This Detail Replaces Ga Standard 9031W

Guidelines For Usage On Metric Projects  
When these details are incorporated into plans and or projects that are being prepared or constructed in metric units, exact or precise conversion to metric units is not required. The dimensions shown that are in feet and inches may be converted to corresponding metric units using the following "Rounded-Off" conversion factors: 1" = 25mm, 4" = 100mm, and 12" or 1' = 300mm. All measurement notes that refer to linear feet and square yards shall be interpreted to mean linear meters and square meters.

REV.	DESCRIPTION	DATE	REVISION
6-18-09	REV. SLOPES TO PERCENT AND ADDED I24 & I01 CHART.	6-18-09	
GLO	ADDED GEN. NOTE NO. 8.	5-10-06	
GLO	REV. TRUNCATED DOMES	2-21-03	
	REVISED	2-10-03	
	REVISED	7-29-02	
	REVISED	5-29-02	
	REVISED	5-23-02	
	REVISED	5-13-02	
	REVISED	4-29-02	
	REVISED	4-11-02	
	REVISED	4-3-02	
	REVISED	3-28-02	

DEPARTMENT OF TRANSPORTATION  
STATE OF GEORGIA

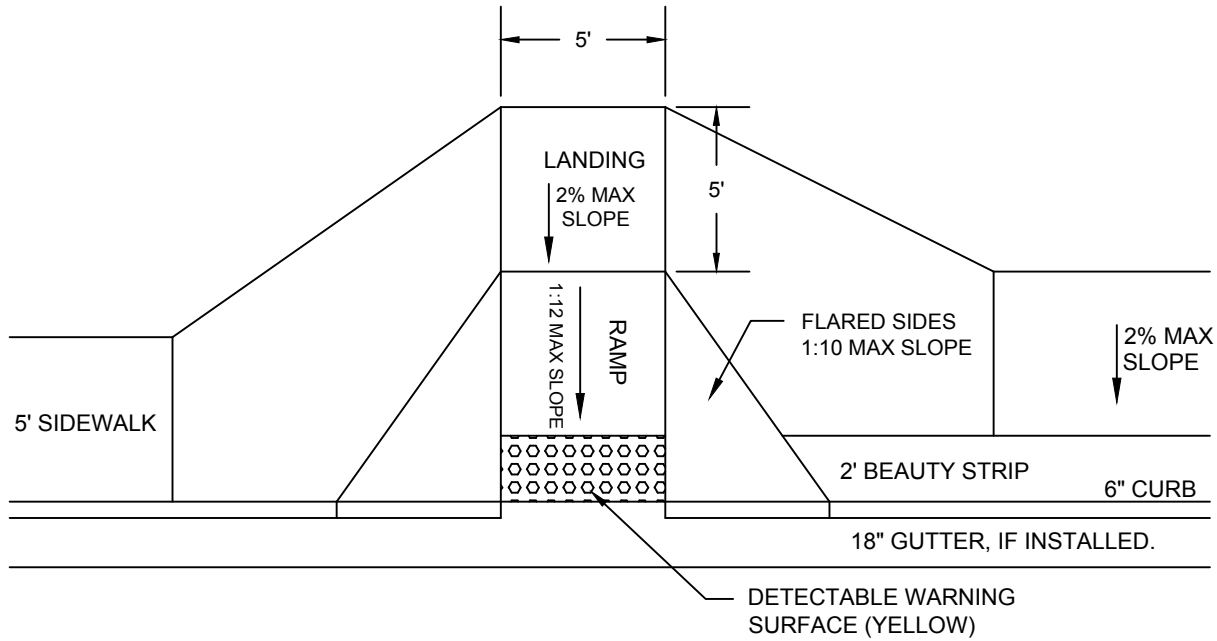
SPECIAL DETAIL  
CONCRETE SIDEWALK DETAILS  
CURB CUT (WHEELCHAIR) RAMPS

NO SCALE

MARCH 12, 2002

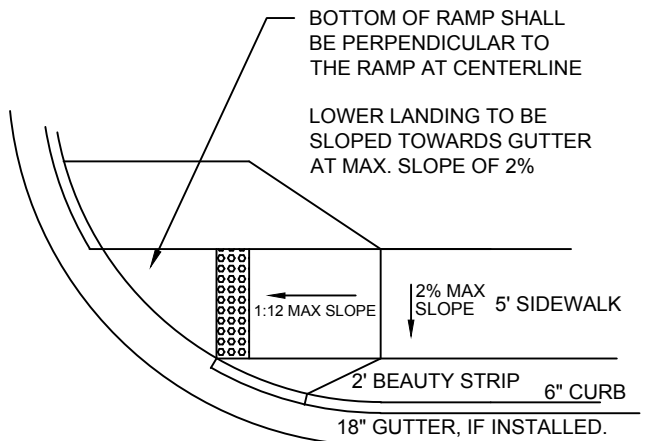
NUMBER  
A3

**EXHIBIT M (TASK 2)**  
**SPECIFICATIONS, LOCATIONS & DETAILS FOR ADA RAMP/SIDEWALK REPAIR/REPLACE**



**GENERAL NOTES:**

1. RAMP SHALL BE CONSTRUCTED FROM CONCRETE. SPECIFICATIONS FOR RAMP SHALL BE THE SAME AS FOR SIDEWALK. RAMP SHALL HAVE EITHER A ROUGH OR TEXTURED FINISH.
2. WHERE RAMP ARE LOCATED ON RADII, THE DIMENSIONS SHOWN FOR RAMP WIDTHS AND TAPERS ARE MEASURED PERPENDICULAR TO THE RAMP AND NOT ALONG THE CURVE.
3. WHERE UTILITY STRUCTURES CONFLICT, THERE SIDEWALK GEOMETRY VARIES, AT SKEWED INTERSECTIONS, OR IN OTHER SPECIAL CASES, THE RAMP DESIGNS MAY BE MODIFIED BY THE DESIGNER OR ENGINEER, PROVIDED THAT THE WIDTH REMAINS A MIN. OF 48" AND NO SLOPE ON THE ACCESSIBLE PART OF THE RAMP IS STEEPER THAT 12:1.
4. WHEN A CURB RAMP IS PLACED ON EXISTING PAVEMENT, THE PAVEMENT SHALL BE REMOVED TO PROVIDE A MINIMUM THICKNESS OF 3" OF CONCRETE AT ALL LOCATIONS.
5. DETECTABLE WARNING SURFACES ARE REQUIRED ON ALL INTERSECTIONS WITH PUBLIC STREETS, SIGNALIZED COMMERCIAL DRIVEWAYS, AND COMMERCIAL DRIVEWAYS WITH AN AADT OF 25 VPD.
6. REFERENCE SHOULD BE MADE TO GDOT STANDARD A3, SPECIAL DETAIL CONCRETE SIDEWALK DETAILS, CURB CUT (WHEELCHAIR) RAMP AND GDOT STANDARD A4, SPECIAL DETAIL DETECTABLE WARNING SURFACE TRUNCATED DOME SIZE, SPACING AND ALIGNMENT REQUIREMENTS.



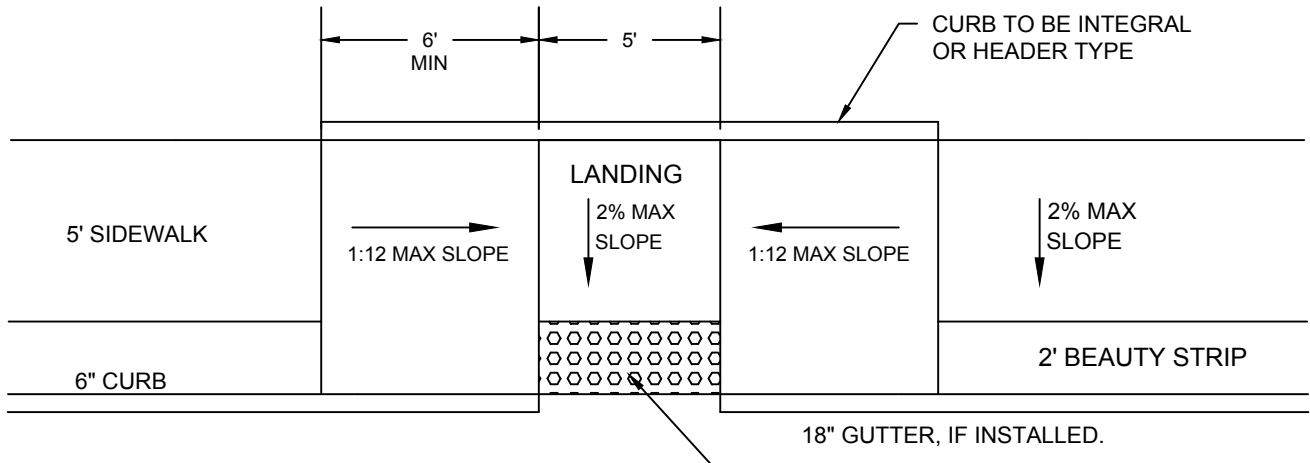
SKEWED RAMP DETAIL  
 TYPE "A" AND "D" RAMP ONLY

NOT TO SCALE

**CITY OF BROOKHAVEN**  
**PUBLIC WORKS DEPARTMENT**  
**HANDICAP RAMP**  
**TYPE "A"**



**EXHIBIT M (TASK 2)  
SPECIFICATIONS, LOCATIONS & DETAILS FOR ADA RAMP/SIDEWALK REPAIR/REPLACE**



NOTE:  
WHERE SIDEWALK ABUTS BACK OF CURB  
LANDING AREA MAY BE REDUCED TO 3' MIN  
DEPTH BEHIND DETECTABLE WARNING SURFACE.

DETECTABLE WARNING  
SURFACE (YELLOW)

**GENERAL NOTES:**

1. RAMPS SHALL BE CONSTRUCTED FROM CONCRETE. SPECIFICATIONS FOR RAMPS SHALL BE THE SAME AS FOR SIDEWALK. RAMPS SHALL HAVE EITHER A ROUGH OR TEXTURED FINISH.
2. WHERE RAMPS ARE LOCATED ON RADII, THE DIMENSIONS SHOWN FOR RAMP WIDTHS AND TAPERS ARE MEASURED PERPENDICULAR TO THE RAMP AND NOT ALONG THE CURVE.
3. WHERE UTILITY STRUCTURES CONFLICT, THERE SIDEWALK GEOMETRY VARIES, AT SKEWED INTERSECTIONS, OR IN OTHER SPECIAL CASES, THE RAMP DESIGNS MAY BE MODIFIED BY THE DESIGNER OR ENGINEER, PROVIDED THAT THE WIDTH REMAINS A MIN. OF 48" AND NO SLOPE ON THE ACCESSIBLE PART OF THE RAMP IS STEEPER THAT 12:1.
4. WHEN A CURB RAMP IS PLACED ON EXISTING PAVEMENT, THE PAVEMENT SHALL BE REMOVED TO PROVIDE A MINIMUM THICKNESS OF 3" OF CONCRETE AT ALL LOCATIONS.
5. DETECTABLE WARNING SURFACES ARE REQUIRED ON ALL INTERSECTIONS WITH PUBLIC STREETS, SIGNALIZED COMMERCIAL DRIVEWAYS, AND COMMERCIAL DRIVEWAYS WITH AN AADT OF 25 VPD.
6. REFERENCE SHOULD BE MADE TO GDOT STANDARD A3, SPECIAL DETAIL CONCRETE SIDEWALK DETAILS, CURB CUT (WHEELCHAIR) RAMPS AND GDOT STANDARD A4, SPECIAL DETAIL DETECTABLE WARNING SURFACE TRUNCATED DOME SIZE, SPACING AND ALIGNMENT REQUIREMENTS.

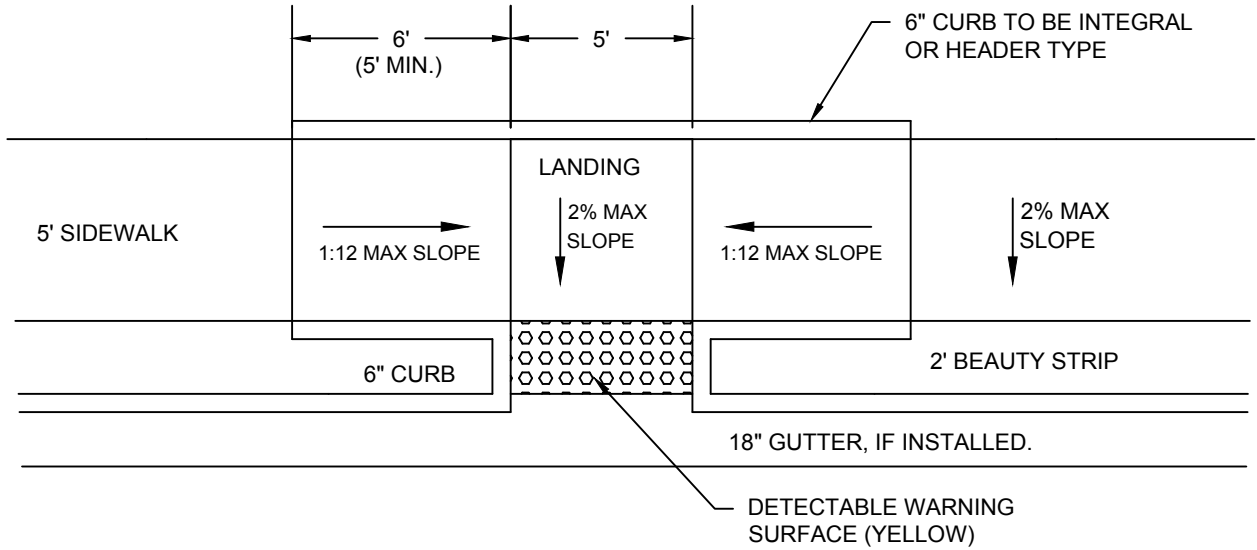
NOT TO SCALE

**CITY OF BROOKHAVEN  
PUBLIC WORKS DEPARTMENT  
HANDICAP RAMP  
TYPE "B"**



APRIL 2019

**EXHIBIT M (TASK 2)**  
**SPECIFICATIONS, LOCATIONS & DETAILS FOR ADA RAMP/SIDEWALK REPAIR/REPLACE**



**GENERAL NOTES:**

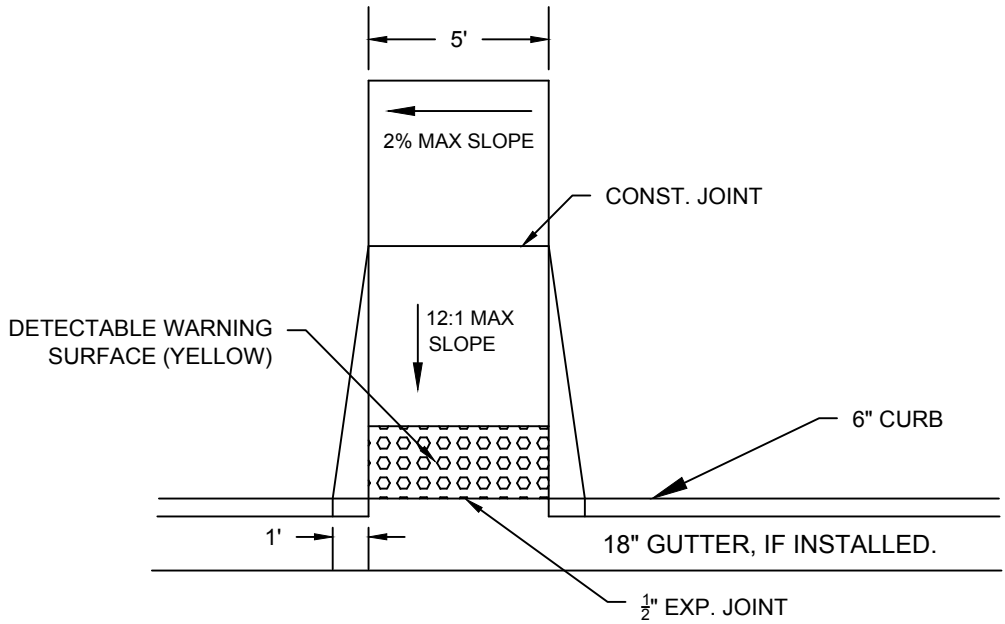
1. RAMPS SHALL BE CONSTRUCTED FROM CONCRETE. SPECIFICATIONS FOR RAMPS SHALL BE THE SAME AS FOR SIDEWALK. RAMPS SHALL HAVE EITHER A ROUGH OR TEXTURED FINISH.
2. WHERE RAMPS ARE LOCATED ON RADII, THE DIMENSIONS SHOWN FOR RAMP WIDTHS AND TAPERS ARE MEASURED PERPENDICULAR TO THE RAMP AND NOT ALONG THE CURVE.
3. WHERE UTILITY STRUCTURES CONFLICT, THERE SIDEWALK GEOMETRY VARIES, AT SKEWED INTERSECTIONS, OR IN OTHER SPECIAL CASES, THE RAMP DESIGNS MAY BE MODIFIED BY THE DESIGNER OR ENGINEER, PROVIDED THAT THE WIDTH REMAINS A MIN. OF 48" AND NO SLOPE ON THE ACCESSIBLE PART OF THE RAMP IS STEEPER THAT 12:1.
4. WHEN A CURB RAMP IS PLACED ON EXISTING PAVEMENT, THE PAVEMENT SHALL BE REMOVED TO PROVIDE A MINIMUM THICKNESS OF 3" OF CONCRETE AT ALL LOCATIONS.
5. DETECTABLE WARNING SURFACES ARE REQUIRED ON ALL INTERSECTIONS WITH PUBLIC STREETS, SIGNALIZED COMMERCIAL DRIVEWAYS, AND COMMERCIAL DRIVEWAYS WITH AN AADT OF 25 VPD.
6. REFERENCE SHOULD BE MADE TO GDOT STANDARD A3, SPECIAL DETAIL CONCRETE SIDEWALK DETAILS, CURB CUT (WHEELCHAIR) RAMPS AND GDOT STANDARD A4, SPECIAL DETAIL DETECTABLE WARNING SURFACE TRUNCATED DOME SIZE, SPACING AND ALIGNMENT REQUIREMENTS.

NOT TO SCALE

**CITY OF BROOKHAVEN**  
**PUBLIC WORKS DEPARTMENT**  
**HANDICAP RAMP**  
**TYPE "C"**  
**PARALLEL ALIGNMENT**

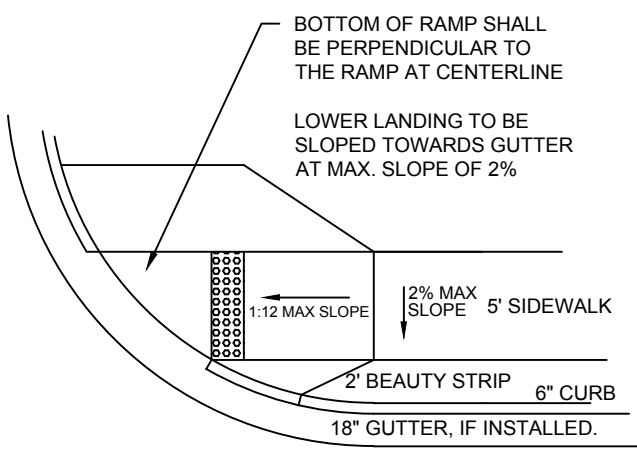


**EXHIBIT M (TASK 2)**  
**SPECIFICATIONS, LOCATIONS & DETAILS FOR ADA RAMP/SIDEWALK REPAIR/REPLACE**



**GENERAL NOTES:**

1. RAMPS SHALL BE CONSTRUCTED FROM CONCRETE. SPECIFICATIONS FOR RAMPS SHALL BE THE SAME AS FOR SIDEWALK. RAMPS SHALL HAVE EITHER A ROUGH OR TEXTURED FINISH.
2. WHERE RAMPS ARE LOCATED ON RADII, THE DIMENSIONS SHOWN FOR RAMP WIDTHS AND TAPERS ARE MEASURED PERPENDICULAR TO THE RAMP AND NOT ALONG THE CURVE.
3. WHERE UTILITY STRUCTURES CONFLICT, THERE SIDEWALK GEOMETRY VARIES, AT SKEWED INTERSECTIONS, OR IN OTHER SPECIAL CASES, THE RAMP DESIGNS MAY BE MODIFIED BY THE DESIGNER OR ENGINEER, PROVIDED THAT THE WIDTH REMAINS A MIN. OF 48" AND NO SLOPE ON THE ACCESSIBLE PART OF THE RAMP IS STEEPER THAT 12:1.
4. WHEN A CURB RAMP IS PLACED ON EXISTING PAVEMENT, THE PAVEMENT SHALL BE REMOVED TO PROVIDE A MINIMUM THICKNESS OF 3" OF CONCRETE AT ALL LOCATIONS.
5. DETECTABLE WARNING SURFACES ARE REQUIRED ON ALL INTERSECTIONS WITH PUBLIC STREETS, SIGNALIZED COMMERCIAL DRIVEWAYS, AND COMMERCIAL DRIVEWAYS WITH AN AADT OF 25 VPD.
6. REFERENCE SHOULD BE MADE TO GDOT STANDARD A3, SPECIAL DETAIL CONCRETE SIDEWALK DETAILS, CURB CUT (WHEELCHAIR) RAMPS AND GDOT STANDARD A4, SPECIAL DETAIL DETECTABLE WARNING SURFACE TRUNCATED DOME SIZE, SPACING AND ALIGNMENT REQUIREMENTS.



SKEWED RAMP DETAIL  
 TYPE "A" AND "D" RAMPS ONLY

NOT TO SCALE

**CITY OF BROOKHAVEN**  
**PUBLIC WORKS DEPARTMENT**  
**HANDICAP RAMP**  
**TYPE "D"**



APRIL 2019

**EXHIBIT N**  
**CDBG FEDERAL/LOCAL PROJECT REQUIREMENTS**

**REQUIREMENTS FOR FEDERALLY ASSISTED CONSTRUCTION PROJECTS**

This project is funded wholly (or in part) by the Community Development Block Grant Program. Since this is a federally funded project, several federal requirements must be followed, including the Davis-Bacon Act (DBA), the Contract Work Hours and Safety Standards Act (CWHSSA), the Copeland Act (Anti-Kickback Act), and the Fair Labor Standards Act (FLSA) and others.

The contractor is responsible for the labor standards compliance of all subcontractors and lower-tier contractors and for ensuring that the Labor Standards Provisions for this project and the applicable wage decisions are included in all subcontractors and lower-tier contracts. In addition to complying with federal regulations, **the contractor must attend a pre-construction meeting with the City of Brookhaven Community Development staff prior to starting construction.** Below are basic explanations of the relevant regulations, to which the contract must comply. The following is a list of federal requirements which must be included in the Request for Proposals:

**Fair Housing and Equal Opportunity**

Title VI of the Civil Rights Act of 1964, As amended:

No person may be excluded from participation in, denied benefits of, or subjected to discrimination under any program or activity receiving Federal assistance based on race, color, or national origin. The regulations implementing the Title VI Civil Rights Act provisions for HUD programs are found in 24 CFR Part 1.

Age Discrimination Act of 1975, As Amended:

Prohibits age discrimination in programs receiving Federal financial assistance. Regulations may be found in 24 CFR Part 146.

Section 109 of Title I of the Housing and Community Development Act of 1974: Requires that no person shall be excluded from participation in, be denied benefits of, or be subjected to discrimination under any program or activity funded with CDBG funds based on race, color, religion, national origin, or sex.

**Handicapped Accessibility**

Americans with Disabilities Act:

The Act provides comprehensive civil rights to individuals with disabilities in the areas concerning employment, public accommodations, telecommunications, and state and local government Contractors. The Act also states that discrimination includes the failure to design and construct facilities that are accessible to and usable by persons with disabilities. This Act also requires the removal of architectural and communication barriers that are structural in nature in existing facilities. Removal must be readily achievable, easily accomplishable, and able to be carried out without much difficulty or expense.

**Section 504:**

Section 504 of the Rehabilitation Act of 1973 prohibits discrimination in Federally assisted programs based on handicap.

Architectural Barriers Act of 1968:

Federal and federally funded buildings and other facilities are to be designed, constructed, or altered per standards that ensure accessibility to, and use by, physically handicapped people.

**EXHIBIT N**  
**CDBG FEDERAL/LOCAL PROJECT REQUIREMENTS**

**Employment and Contracting**

Equal Employment Opportunity, Executive Order 11246, as amended:

Prohibits discrimination against any employee or applicant for employment because of race, color, religion, sex, or national origin. Provisions to effectuate this prohibition must be included in all construction contracts exceeding \$10,000.

Section 3 of the Housing and Urban Development Act of 1968:

Requires that, to the greatest extent feasible, opportunities for training and employment arising from CDBG be provided to low-income people residing in the program Contractor area. To the greatest extent feasible, contracts for work to be performed in connection with CDBG will be awarded to business concerns that are in or owned by persons residing in the program Contractor area.

Minority/Women's Business Enterprise:

Grantees must prescribe procedures acceptable to HUD for a minority outreach program to ensure the inclusion to the maximum extent possible, of minorities and women, and entities owned by minorities and women, in all contracts.

Davis-Bacon and Related Acts:

Ensures that mechanics and laborers employed in construction work under Federally assisted contracts are paid wages and fringe benefits equal to those that prevail in the locality where the work is performed. This act provides for the withholding of funds to ensure compliance and excludes from the wage requirements apprentices enrolled in bona fide apprenticeship programs.

The Contract Work Hours and Safety Standards Act (CWHSSA)

This Act requires time and one-half pay for any overtime hours worked on the covered project. Overtime hours are defined as hours worked in any one workweek more than 40 hours.

The Copeland Act (Anti-Kickback Act)

This Act prohibits any employer from requiring a laborer or mechanic to kickback any part of their wages. In accordance with this Act, every employer (contractors and subcontractors) must submit weekly payrolls for review.

Fair Labor Standards Act:

Establishes the basic minimum wage for all work and requires the payment of overtime at the rate of at least time and one-half. It also requires the payment of wages for the entire time that an employee is required or permitted to work and establishes child labor standards.

Conflict-of-Interest:

In accordance with 24 CFR 570.611, no person who exercises (or has exercised) any functions or responsibilities with respect to CDBG activities (or who is in the position to participate in decisions or gain inside information) may obtain a financial interest or benefit from a CDBG activity or have an interest in any contract, subcontract, or agreement for themselves or for persons with business or family ties.



**EXHIBIT O**  
**CDBG FEDERAL/LOCAL PROJECT REQUIREMENTS**

**A Standard Federal-Aid Contract  
for  
Locally Administered or Locally Let Projects**

Shall contain at a minimum, the following contract information, documents, and provisions:

General Information:

- ✓ Date of Bid Opening
- ✓ Project Description (Include Counties, GDOT P.I. Nos. and GDOT District)
- ✓ Contract time: Must include time for utility adjustment schedule, material lead time, seasonal and environmental limitations, and coordination time with other entities.
- ✓ Project Schedule: List of activities with start and end dates
- ✓ Schedule of Items: Including unit prices and estimated quantities (No Lump Sum items allowed)
- ✓ Contract Proposal Index: This shall include a list of provisions in the contract proposal.
- ✓ Materials Testing & Inspections Statement: List the Responsible Party by Agency or contractor.

Provisions to be included are:

1. Proposal Index
2. DBE Requirements – Pages 3 - 5
3. Bid Opportunity List – Page 6
4. Georgia Security and Immigration Compliance Act Affidavit – Page 7
5. Federal Aid Requirements – Page 8
6. Certification/Drug-Free Workplace – Page 9
7. Non-Collusion/Signature Page – Page 10
8. Notice to All Bidders – Pages 11 - 12
9. Federal Labor Provisions (FHWA 1273) – Pages 13 - 24
10. Required Contract Provisions Federal-Aid Contracts – Pages 25 - 26
11. Notice to Contractors – Page 27
12. Wage Rates – Pages 28 – 29
 

**\*Note:** *“Davis Bacon Wage Rates” apply to all projects. The applicable wage rate determination posted on the Davis Bacon website of the U.S. Department of Labor <http://www.wdol.gov/dba.aspx#0> applies to this project. If a modification is posted less than 10 days before the opening of bids, it shall be effective unless the Sponsor finds that there is not a reasonable time still available before bid opening to notify bidders of the modification and a report of the finding is inserted in the contract file (29 CFR 1.6(c)(3)).*
13. Standard EEO Specifications – Pages 30 - 33
14. Notice of Affirmative Action – Pages 34 - 36
15. Disadvantaged Business Enterprise Program – Pages 37 - 49
16. Prompt Payment – Page 50
17. Buy America – Page 51
18. Utility Conflicts – Pages 52 - 53
19. Any other Specifications or Special Provision not included in 2013 Standard Specifications & any Supplemental Specifications that is required based on the pay items included in the Schedule of items.
20. Any Special Conditions

**EXHIBIT O**  
**CDBG FEDERAL/LOCAL PROJECT REQUIREMENTS**

**Required Special Provisions & Supplemental Specifications:**

- Sec. 107 – Legal Regulations and Responsibility to the Public – Pages 54 - 69
- Sec. 109 – Measurement and Payment – Pages 70 - 80
- Sec. 109 – Measurement and Payment – Pages 81 - 82
- Sec. 150 – Traffic Control, *(Not included in this contract package template).*
- Sec. 161 – Control of Soil Erosion and Sedimentation – Pages 83 - 93
- Sec. 163 – Miscellaneous Erosion Control – Pages 94 - 103
- Sec. 167 – Water Quality Monitoring – Pages 104 - 109
- Sec. 171—Silt Fence – Pages 110 - 113
- Sec. 201 – Clearing and Grubbing Right of Way – Pages 114 - 116
- Sec. 797 – Buildings (If applicable), *(Not included in this contract package template).*

**EXHIBIT O  
CDBG FEDERAL/LOCAL PROJECT REQUIREMENTS**

First Use: March 23, 1990

**DBE GOALS**

VENDOR ID: \_\_\_\_\_ BIDDER'S COMPANY NAME: \_\_\_\_\_

PROJECT NO. & COUNTY: \_\_\_\_\_

LET NO: \_\_\_\_\_ LET DATE: \_\_\_\_\_

TOTAL BID: \_\_\_\_\_

THE REQUIRED DBE GOAL ON THIS CONTRACT IS: 13%

I PROPOSE TO UTILIZE THE FOLLOWING DBEs:

**LIST OF DBE PARTICIPANTS**

<b>*VENDOR NUMBER</b>	<b>DBE NAME/ ADDRESS (CITY, STATE)</b>	<b>TYPE OF WORK</b>	<b>RACE Neutral</b>	<b>Race Conscious</b>	<b>*WORK CODE</b>	<b>AMOUNT</b>
<b>TOTAL</b>						

\* For Departmental use only. Do not fill in Work codes.

**PLEASE NOTE :** Only 60% of the participation of a DBE Supplier who does not manufacture or install the product will be counted toward the goal. See below for further instructions.

**EXHIBIT O**  
**CDBG FEDERAL/LOCAL PROJECT REQUIREMENTS**

**INSTRUCTIONS FOR LIST OF DBE PARTICIPANTS**

If a DBE Goal is indicated, you must propose to achieve a goal that is equal or greater than the percentage required. If no goal is indicated, you may propose your own goal.

The DBE Firms to be utilized as counting toward the proposed goal must be listed on this form, along with their addresses, type of work and the amount to be paid to each of the minority firms. The amount entered will not necessarily be the contract amount but must be the actual amount that will be paid to the DBE firm. In the case of a DBE supplier, the amount paid and 60% of that amount shall be entered and only the 60% figure should be added to the total. An example of this is shown in the example chart:

Vendor Number	Company Name And Address (City and State)	Type of Work	* Work Code	Race Neutral	Race Conscious	Amount
	ABC Oil Company Atlanta, GA	Diesel Fuel Supplier				\$80,000.00 (60% = \$48,000.00)

\* For Departmental use ONLY. Do not fill in Work Codes.

The Contractor shall indicate for each DBE and Type of Work whether the DBE Participant is race-neutral or Race Conscious by placing a checkmark in the appropriate column.

**PLEASE NOTE:** For 60% of the amount paid to a DBE supplier to be eligible to count toward fulfilling the DBE goal, the supplier must be an established “regular dealer” in the product involved and not just a broker. A “regular dealer” would normally sell the product to several customers and would usually have product inventory on hand.

**EXHIBIT O  
CDBG FEDERAL/LOCAL PROJECT REQUIREMENTS  
MONTHLY DBE PARTICIPATION REPORT**

REPORT SUBMISSION DATE: \_\_\_\_\_

PROJECT NO.: \_\_\_\_\_  
 COUNTY: \_\_\_\_\_  
 CONTRACT ID NO.: \_\_\_\_\_  
 CONTRACTOR: \_\_\_\_\_

REPORT NO.: \_\_\_\_\_

NOTICE TO PROCEED: \_\_\_\_\_  
 DATE WORK BEGAN: \_\_\_\_\_ DBE REQUIRED %: \_\_\_\_\_  
 CONTRACT \$ AMOUNT: \_\_\_\_\_ % DOLLAR COMPLETE: \_\_\_\_\_  
 DBE \$ AMOUNT: \_\_\_\_\_ \$ 0.00 % PROJECT COMPLETE: \_\_\_\_\_

31-Jan	<input type="checkbox"/>	31-Jul	<input type="checkbox"/>
28-Feb	<input type="checkbox"/>	31-Aug	<input type="checkbox"/>
<b>31-Mar</b>	<input type="checkbox"/>	<b>30-Sep</b>	<input type="checkbox"/>
30-Apr	<input type="checkbox"/>	31-Oct	<input type="checkbox"/>
31-May	<input type="checkbox"/>	30-Nov	<input type="checkbox"/>
<b>30-Jun</b>	<input type="checkbox"/>	<b>31-Dec</b>	<input type="checkbox"/>

S = SUPPLIER SC = SUBCONTRACTOR

	APPROVED DBE		VENDOR ID	DESCRIPTION OF WORK		
	S	SC		ORIGINAL SUBCONTRACT AMOUNT	PREVIOUS PAYMENTS	PAYMENTS THIS REPORT
<b>1</b>						
RN	<input type="checkbox"/>	<input type="checkbox"/>				\$ 0.00
RC	<input type="checkbox"/>	<input type="checkbox"/>				\$ 0.00
<b>2</b>						
RN	<input type="checkbox"/>	<input type="checkbox"/>				\$ 0.00
RC	<input type="checkbox"/>	<input type="checkbox"/>				\$ 0.00
<b>3</b>						
RN	<input type="checkbox"/>	<input type="checkbox"/>				\$ 0.00
RC	<input type="checkbox"/>	<input type="checkbox"/>				\$ 0.00
<b>4</b>						
RN	<input type="checkbox"/>	<input type="checkbox"/>				\$ 0.00
RC	<input type="checkbox"/>	<input type="checkbox"/>				\$ 0.00
<b>5</b>						
RN	<input type="checkbox"/>	<input type="checkbox"/>				\$ 0.00
RC	<input type="checkbox"/>	<input type="checkbox"/>				\$ 0.00
<b>6</b>						
RN	<input type="checkbox"/>	<input type="checkbox"/>				\$ 0.00
RC	<input type="checkbox"/>	<input type="checkbox"/>				\$ 0.00
<b>RN COLUMN TOTALS:</b>				\$ 0.00	\$ 0.00	\$ 0.00
<b>RC COLUMN TOTALS:</b>				\$ 0.00	\$ 0.00	\$ 0.00

**TOTAL % PAID TO DATE:** \_\_\_\_\_

I HEREBY CERTIFY THAT THE ABOVE STATEMENT IS TRUE AND CORRECT AND SUPPORTING DOCUMENTATION IS ON FILE AND IS AVAILABLE FOR INSPECTION BY DEPARTMENT PERSONNEL AT ANY TIME. ALL PARTICIPATION COUNTED TOWARD FULFILLMENT OF THE DBE GOALS IS (1) REAL AND SUBSTANTIAL; (2) ACTUALLY PERFORMED BY VIABLE, INDEPENDENT DBE OWNED FIRMS; AND (3) IN ACCORDANCE WITH THE SPIRIT OF APPLICABLE LAWS AND REGULATIONS.

PRINT NAME: \_\_\_\_\_

NAME / TITLE

SIGNATURE: \_\_\_\_\_

**FOR DEPARTMENT USE ONLY**

**THIS DOCUMENT HAS BEEN REVIEWED AT THE PROJECT LEVEL BY:**

PRINT NAME: \_\_\_\_\_

NAME / TITLE

SIGNATURE: \_\_\_\_\_

(Mandatory)

**THIS DOCUMENT HAS BEEN REVIEWED AT THE DISTRICT LEVEL BY:**

PRINT NAME: \_\_\_\_\_

NAME / TITLE

**EXHIBIT O**  
**CDBG FEDERAL/LOCAL PROJECT REQUIREMENTS**

SIGNATURE: \_\_\_\_\_  
(Mandatory)

**EXHIBIT O**  
**CDBG FEDERAL/LOCAL PROJECT REQUIREMENTS**

STATE OF GEORGIA DEPARTMENT OF TRANSPORTATION  
CONSTRUCTION CONTRACTORS  
BID OPPORTUNITY LIST

FORM EEOP  
PREQUALIFICATION OFFICE  
Revised 05/16/11

Please complete and mail or FAX to:  
Construction Bidding Administration  
600 West Peachtree Street, NW  
Suite 1113  
Atlanta, Georgia 30308  
TELEPHONE: (404) 631-1147  
FAX: (404) 631-1275

This information shall be submitted in accordance with Specification Section 102.18

---

Prime Contractor/Consultant: \_\_\_\_\_  
Address/Telephone Number: \_\_\_\_\_  
Bid/Proposal Number: \_\_\_\_\_  
Quote Submitted MM/YY: \_\_\_\_\_

49 CRF Part 26.11 requires the Georgia Department of Transportation to develop and maintain a "bid opportunity list". The list is intended to be a listing of all firms participating or attempting to participate, on DOT assisted contracts. The list must include all firms that bid on prime contracts, or bid or quote subcontracts and materials supplies on DOT-assisted projects, including both DBEs and non-DBEs. For consulting companies this list must include all subconsultants contacting you and expressing an interest in teaming with you on a specific DOT assisted project. Prime contractors and consultants must provide information for Nos. 1, 2, 3, and 4 and must provide information they have available on Numbers 5, 5.A, 6, 7, 8 and 9 for themselves, and their subcontractors and subconsultants.

- |                                   |                                           |
|-----------------------------------|-------------------------------------------|
| 1. Federal Tax ID Number: _____   | 6. <input type="checkbox"/> DBE           |
| 2. Firm Name: _____               | <input type="checkbox"/> Non-DBE          |
| 3. Phone: _____                   | 7. <input type="checkbox"/> Subcontractor |
| 4. Address: _____                 | 8. <input type="checkbox"/> Subconsultant |
| 5. Contact _____                  | 9. <input type="checkbox"/> Supplier      |
| 5.A. Company E mail address _____ |                                           |

- |                                   |                                           |
|-----------------------------------|-------------------------------------------|
| 1. Federal Tax ID Number: _____   | 6. <input type="checkbox"/> DBE           |
| 2. Firm Name: _____               | <input type="checkbox"/> Non-DBE          |
| 3. Phone: _____                   | 7. <input type="checkbox"/> Subcontractor |
| 4. Address: _____                 | 8. <input type="checkbox"/> Subconsultant |
| 5. Contact _____                  | 9. <input type="checkbox"/> Supplier      |
| 5.A. Company E mail address _____ |                                           |

- |                                   |                                           |
|-----------------------------------|-------------------------------------------|
| 1. Federal Tax ID Number: _____   | 6. <input type="checkbox"/> DBE           |
| 2. Firm Name: _____               | <input type="checkbox"/> Non-DBE          |
| 3. Phone: _____                   | 7. <input type="checkbox"/> Subcontractor |
| 4. Address: _____                 | 8. <input type="checkbox"/> Subconsultant |
| 5. Contact _____                  | 9. <input type="checkbox"/> Supplier      |
| 5.A. Company E mail address _____ |                                           |

**EXHIBIT O  
CDBG FEDERAL/LOCAL PROJECT REQUIREMENTS**



<b>Contractor's Name:</b>	
<b>Solicitation/Contract No./ Call No. or Project Description:</b>	

**CONTRACTOR AFFIDAVIT**

By executing this affidavit, the undersigned contractor verifies its compliance with O.C.G.A. § 13-10-91, stating affirmatively that the individual, entity or corporation which is engaged in the physical performance of services on behalf of the Georgia Department of Transportation has registered with, is authorized to use and uses the federal work authorization program commonly known as E-Verify, or any subsequent replacement program, in accordance with the applicable provisions and deadlines established in O.C.G.A. § 13-10-91.

Furthermore, the undersigned contractor will continue to use the federal work authorization program throughout the contract period and the undersigned contractor will contract for the physical performance of services in satisfaction of such contract only with subcontractors who present an affidavit to the contractor with the information required by O.C.G.A. § 13-10-91(b). Contractor hereby attests that its federal work authorization user identification number and date of authorization are as follows:

\_\_\_\_\_  
Federal Work Authorization User Identification Number  
(EEV/E-Verify Company Identification Number)

\_\_\_\_\_  
Date of Authorization

\_\_\_\_\_  
Name of Contractor

**I hereby declare under penalty of perjury that the foregoing is true and correct**

\_\_\_\_\_  
Printed Name (of Authorized Officer or Agent of Contractor)

\_\_\_\_\_  
Title (of Authorized Officer or Agent of Contractor)

\_\_\_\_\_  
Signature (of Authorized Officer or Agent)

\_\_\_\_\_  
Date Signed

SUBSCRIBED AND SWORN BEFORE ME ON THIS THE

\_\_\_\_ DAY OF \_\_\_\_\_, 20 \_\_\_\_

[NOTARY SEAL]

\_\_\_\_\_  
Notary Public

My Commission Expires: \_\_\_\_\_



**EXHIBIT O**  
**CDBG FEDERAL/LOCAL PROJECT REQUIREMENTS**  
**DEPARTMENT OF TRANSPORTATION**  
**STATE OF GEORGIA**

---

**FEDERAL AID CERTIFICATION**  
(English Project)

First Use Date 2013 Specifications: November 22, 2013

Revised: June 8, 2016

Failure to complete appropriate certification requirements identified below or submission of a false certification shall render the bid non-responsive.

**EQUAL EMPLOYMENT OPPORTUNITY**

I further certify that I have \_\_\_\_/have not \_\_\_\_ participated in a previous contract or subcontract subject to the equal opportunity clause, as required by Executive Orders 10925, 11114, or 11246, and that I have \_\_\_\_/ have not \_\_\_\_ filed with the Joint Reporting Committee, the Director of the *Office of Federal Contract Compliance*, a Federal Government contracting or administering agency, or the former *President's Committee on Equal Employment Opportunity*, all reports due under the applicable filing requirements.

I understand that if I have participated in a previous Contract or Subcontract subject to the Executive Orders above and have not filed the required reports that 41 CFR 60-1.7(b)(1) prevents the award of this Contract unless I submit a report governing the delinquent period or such other period specified by the Federal Highway Administration or by the Director, Office of Federal Contract Compliance, U. S. Department of Labor.

Reports and notifications required under 41 CFR 604, including reporting subcontract awards in excess of \$10,000.00 should be addressed to:

Ms. Carol Gaudin  
Regional Director, U. S. Department of Labor  
Office of Federal Contract Compliance Programs, Region 4  
Rm. 7B75  
61 Forsyth St. SW  
Atlanta GA 30303

**EXAMINATION OF PLANS AND SPECIFICATIONS**

I acknowledge that this Project will be constructed in English units.

I certify that I have carefully examined the Plans for this Project and the Standard Specifications 2013 Edition, Supplemental Specifications and Special Provisions included in and made a part of this Proposal, and have also personally examined the site of the work. On the basis of the said Specifications and Plans, I propose to furnish all necessary machinery, tools, apparatus and other means of construction, and do all the work and furnish all the materials in the manner specified.

I understand the quantities mentioned are approximate only and are subject to either increase or decrease and hereby propose to perform any increased or decreased quantities of work or extra work on the basis provided for in the Specifications.

I also hereby agree that the State, or the Department of Transportation, would suffer damages in a sum equal to at least the amount of the enclosed Proposal Guaranty, in the event my Proposal should be accepted and a Contract tendered me thereunder and I should refuse to execute same and furnish bond as

**EXHIBIT O**  
**CDBG FEDERAL/LOCAL PROJECT REQUIREMENTS**  
**DEPARTMENT OF TRANSPORTATION**  
**STATE OF GEORGIA**

---

herein required, in consideration of which I hereby agree that, in the event of such failure on my part to execute said Contract and furnish bond within fifteen (15) days after the date of the letter transmitting the Contract to me, the amount of said Proposal Guaranty shall be and is hereby, forfeited to the State, or to the Department of Transportation, as liquidated damages as the result of such failure on my part.

I further propose to execute the Contract agreement described in the Specifications as soon as the work is awarded to me, and to begin and complete the work within the time limit provided. I also propose to furnish a Contract Bond, approved by the State Transportation Board, as required by the laws of the State of Georgia. This bond shall not only serve to guarantee the completion of the work on my part, but also to guarantee the excellence of both workmanship and materials until the work is finally accepted, as well as to fully comply with all the laws of the State of Georgia.

**CONFLICT OF INTEREST**

By signing and submitting this Contract I hereby certify that employees of this company or employee of any company supplying material or subcontracting to do work on this Contract will not engage in business ventures with employees of the Georgia Department of Transportation (GA D.O.T.) nor shall they provide gifts, gratuities, favors, entertainment, loans or other items of value to employees of this department.

Also, by signing and submitting this Contract I hereby certify that I will notify the Georgia Department of Transportation through its District Engineer of any business ventures entered into between employees of this company or employees of any company supplying material or subcontracting to do work on this Contract with a family member of GA D.O.T. employees.

**DRUG FREE WORKPLACE**

The undersigned certifies that the provisions of Code Sections 50-24-1 through 50-24-6 of the Official Code of Georgia Annotated, relating to the "Drug-free Workplace Act", have been complied with in full. The undersigned further certifies that:

- (1) A drug-free workplace will be provided for the Contractor's employees during the performance of the Contract; and
- (2) Each Contractor who hires a Subcontractor to work in a drug-free workplace shall secure from that Subcontractor the following written certification:

"As part of the subcontracting agreement with \_\_\_\_\_ (Contractor's name) \_\_\_\_\_, \_\_\_\_\_ (Subcontractor's name) certifies to the Contractor that a drug free workplace will be provided for the Subcontractor's employees during the performance of this Contract pursuant to paragraph (7) of subsection (b) of Code Section 50-24- 3."

Also, the undersigned further certifies that he will not engage in the unlawful manufacture, sale distribution, dispensation, possession, or use of a controlled substance or marijuana during the performance of the Contract.

**BOYCOTT OF ISRAEL**

By signing and submitting this Contract and Pursuant to O.C.G.A. Sec. 50-5-85, CONTRACTOR hereby certifies that it is not currently engaged in, and agrees that for the duration of this contract, it will not engage in a boycott of Israel.

**EXHIBIT O**  
**CDBG FEDERAL/LOCAL PROJECT REQUIREMENTS**  
**DEPARTMENT OF TRANSPORTATION**  
**STATE OF GEORGIA**

---

---

**NON-COLLUSION CERTIFICATION**

I hereby certify that I have not, nor has any member of the firm(s) or corporation(s), either directly or indirectly entered into any agreement, participated in any collusion, nor otherwise taken any action in restraint of free competitive bidding in connection with this submitted bid.

It is understood and agreed that this Proposal is one of several competitive bids made to the Department of Transportation, and in consideration of mutual agreements of the bidders, similar hereto, and in consideration of the sum of One Dollar cash in hand paid, receipt whereof is hereby acknowledged, the undersigned agrees that this Proposal shall be an option, which is hereby given by the undersigned to the Department of Transportation to accept or reject this Proposal at any time within thirty (30) calendar days from the date on which this sealed proposal is opened and read, unless a longer period is specified in the Proposal or the successful bidder agrees in writing to a longer period of time for the award, and in consideration of the premises, it is expressly covenanted and agreed that this Proposal is not subject to withdrawal by the Proposer or Bidder, during the term of said option.

I hereby acknowledge receipt of the following checked amendments of the Proposal, Plans, Specifications and/or other documents pertaining to the Contract.

Amendment Nos.: 1\_\_2\_\_3\_\_4\_\_5\_\_. I understand that failure to confirm the receipt of amendments is cause for rejection of bids.

Witness my hand and seal this the \_\_\_\_ day of \_\_\_\_\_, 20\_\_.

The bidder(s) whose signature(s) appear on this document, having personally appeared before me, and being duly sworn, deposes and says that the above statements are true and correct.

Sworn to and subscribed before me this \_\_\_\_\_ day of \_\_\_\_\_, 20\_\_\_\_\_.

\_\_\_\_\_  
(Notary Public)

My Commission expires the \_\_\_\_\_ day of \_\_\_\_\_, 20\_\_\_\_\_.

\_\_\_\_\_  
(Federal ID No./IRS No.)

\_\_\_\_\_  
(Print Company Name)

By \_\_\_\_\_ (Seal)  
Corporate President/Vice President or  
Individual Owner or Partner (Strike  
through all except the one which applies.)

Joint Bidder:

\_\_\_\_\_  
(Print Company Name)

By \_\_\_\_\_ (Seal)  
Corporate President/Vice President or  
Individual Owner or Partner (Strike  
through all except the one which applies.)

Joint Bidder:

\_\_\_\_\_  
(Print Company Name)

By \_\_\_\_\_ (Seal)  
Corporate President/Vice President or  
Individual Owner or Partner (Strike  
through all except the one which applies.)

**EXHIBIT O  
CDBG FEDERAL/LOCAL PROJECT REQUIREMENTS**

**“BIDDER QUALIFICATIONS”**  
**NOTICE TO ALL BIDDERS**

ALL BIDDERS SUBMITTING BIDS IN EXCESS OF \$2,000,000  
SHALL BE PRE-QUALIFIED WITH THE GEORGIA DEPARTMENT OF  
TRANSPORTATION (GDOT).

ALL BIDDERS SUBMITTING BIDS \$2,000,000  
OR LESS SHALL BE REGISTERED SUBCONTRACTORS OR PRE-QUALIFIED  
WITH THE GDOT.

SUBCONTRACTORS SHALL BE PRE-QUALIFIED OR  
REGISTERED WITH THE GDOT.

IF CONSTRUCTION WORK INVOLVES WELDED STRUCTURES,  
SUCH AS BRIDGES, THE MANUFACTURER OF THE  
STRUCTURE SHALL BE ON THE GDOT QPL LIST 60.

EXHIBIT O  
CDBG FEDERAL/LOCAL PROJECT REQUIREMENTS

# NOTICE TO ALL BIDDERS

To report bid rigging activities, call:

**1-800-424-9071**

The U.S. Department of Transportation (DOT) operates the above toll-free “hotline” Monday through Friday, 8:00 AM to 5:00 PM, Eastern Time. Anyone with the knowledge of possible bid rigging, bidder collusion, or other fraudulent activities should use the “hotline” to report such activities.

The “hotline” is part of the DOT’s continuing effort to identify and investigate highway construction contract fraud and abuse and is operated under the direction of the DOT Inspector General. All information will be treated confidentially, and caller anonymity will be respected.

## EXHIBIT O

### CDBG FEDERAL/LOCAL PROJECT REQUIREMENTS

FHWA-1273 -- Revised May 1, 2012

#### REQUIRED CONTRACT PROVISIONS FEDERAL-AID CONSTRUCTION CONTRACTS

- I. General
- II. Nondiscrimination
- III. Nonsegregated Facilities
- IV. Davis-Bacon and Related Act Provisions
- V. Contract Work Hours and Safety Standards Act Provisions
- VI. Subletting or Assigning the Contract
- VII. Safety: Accident Prevention
- VIII. False Statements Concerning Highway Projects
- IX. Implementation of Clean Air Act and Federal Water Pollution Control Act
- X. Compliance with Governmentwide Suspension and Debarment Requirements
- XI. Certification Regarding Use of Contract Funds for Lobbying

#### ATTACHMENTS

A. Employment and Materials Preference for Appalachian Development Highway System or Appalachian Local Access Road Contracts (included in Appalachian contracts only)

#### I. GENERAL

1. Form FHWA-1273 must be physically incorporated in each construction contract funded under Title 23 (excluding emergency contracts solely intended for debris removal). The contractor (or subcontractor) must insert this form in each subcontract and further require its inclusion in all lower tier subcontracts (excluding purchase orders, rental agreements and other agreements for supplies or services).

The applicable requirements of Form FHWA-1273 are incorporated by reference for work done under any purchase order, rental agreement or agreement for other services. The prime contractor shall be responsible for compliance by any subcontractor, lower-tier subcontractor or service provider.

Form FHWA-1273 must be included in all Federal-aid design-build contracts, in all subcontracts and in lower tier subcontracts (excluding subcontracts for design services, purchase orders, rental agreements and other agreements for supplies or services). The design-builder shall be responsible for compliance by any subcontractor, lower-tier subcontractor or service provider.

Contracting agencies may reference Form FHWA-1273 in bid proposal or request for proposal documents, however, the Form FHWA-1273 must be physically incorporated (not referenced) in all contracts, subcontracts and lower-tier subcontracts (excluding purchase orders, rental agreements and other agreements for supplies or services related to a construction contract).

2. Subject to the applicability criteria noted in the following sections, these contract provisions shall apply to all work performed on the contract by the contractor's own organization and with the assistance of workers under the contractor's immediate superintendence and to all work performed on the contract by piecework, station work, or by subcontract.

3. A breach of any of the stipulations contained in these Required Contract Provisions may be sufficient grounds for withholding of progress payments, withholding of final payment, termination of the contract, suspension/debarment or any other action determined to be appropriate by the contracting agency and FHWA.

4. Selection of Labor: During the performance of this contract, the contractor shall not use convict labor for any purpose within the limits of a construction project on a Federal-aid highway unless it is labor performed by convicts who are on parole, supervised release, or probation. The term Federal-aid highway does not include roadways functionally classified as local roads or rural minor collectors.

#### II. NONDISCRIMINATION

The provisions of this section related to 23 CFR Part 230 are applicable to all Federal-aid construction contracts and to all related construction subcontracts of \$10,000 or more. The provisions of 23 CFR Part 230 are not applicable to material supply, engineering, or architectural service contracts.

In addition, the contractor and all subcontractors must comply with the following policies: Executive Order 11246, 41 CFR 60, 29 CFR 1625-1627, Title 23 USC Section 140, the Rehabilitation Act of 1973, as amended (29 USC 794), Title VI of the Civil Rights Act of 1964, as amended, and related regulations including 49 CFR Parts 21, 26 and 27; and 23 CFR Parts 200, 230, and 633.

The contractor and all subcontractors must comply with: the requirements of the Equal Opportunity Clause in 41 CFR 60-1.4(b) and, for all construction contracts exceeding \$10,000, the Standard Federal Equal Employment Opportunity Construction Contract Specifications in 41 CFR 60-4.3.

Note: The U.S. Department of Labor has exclusive authority to determine compliance with Executive Order 11246 and the policies of the Secretary of Labor including 41 CFR 60, and 29 CFR 1625-1627. The contracting agency and the FHWA have the authority and the responsibility to ensure compliance with Title 23 USC Section 140, the Rehabilitation Act of 1973, as amended (29 USC 794), and Title VI of the Civil Rights Act of 1964, as amended, and related regulations including 49 CFR Parts 21, 26 and 27; and 23 CFR Parts 200, 230, and 633.

The following provision is adopted from 23 CFR 230, Appendix A, with appropriate revisions to conform to the U.S. Department of Labor (US DOL) and FHWA requirements.

**1. Equal Employment Opportunity:** Equal employment opportunity (EEO) requirements not to discriminate and to take affirmative action to assure equal opportunity as set forth under laws, executive orders, rules, regulations (28 CFR 35, 29 CFR 1630, 29 CFR 1625-1627, 41 CFR 60 and 49 CFR 27) and orders of the Secretary of Labor as modified by the provisions prescribed herein, and imposed pursuant to 23 U.S.C. 140 shall constitute the EEO and specific affirmative action standards for the contractor's project activities under

## EXHIBIT O

### CDBG FEDERAL/LOCAL PROJECT REQUIREMENTS

this contract. The provisions of the Americans with Disabilities Act of 1990 (42 U.S.C. 12101 et seq.) set forth under 28 CFR 35 and 29 CFR 1630 are incorporated by reference in this contract. In the execution of this contract, the contractor agrees to comply with the following minimum specific requirement activities of EEO:

a. The contractor will work with the contracting agency and the Federal Government to ensure that it has made every good faith effort to provide equal opportunity with respect to all of its terms and conditions of employment and in their review of activities under the contract.

b. The contractor will accept as its operating policy the following statement:

"It is the policy of this Company to assure that applicants are employed, and that employees are treated during employment, without regard to their race, religion, sex, color, national origin, age or disability. Such action shall include: employment, upgrading, demotion, or transfer; recruitment or recruitment advertising; layoff or termination; rates of pay or other forms of compensation; and selection for training, including apprenticeship, pre-apprenticeship, and/or on-the-job training."

**2. EEO Officer:** The contractor will designate and make known to the contracting officers an EEO Officer who will have the responsibility for and must be capable of effectively administering and promoting an active EEO program and who must be assigned adequate authority and responsibility to do so.

**3. Dissemination of Policy:** All members of the contractor's staff who are authorized to hire, supervise, promote, and discharge employees, or who recommend such action, or who are substantially involved in such action, will be made fully cognizant of, and will implement, the contractor's EEO policy and contractual responsibilities to provide EEO in each grade and classification of employment. To ensure that the above agreement will be met, the following actions will be taken as a minimum:

a. Periodic meetings of supervisory and personnel office employees will be conducted before the start of work and then not less often than once every six months, at which time the contractor's EEO policy and its implementation will be reviewed and explained. The meetings will be conducted by the EEO Officer.

b. All new supervisory or personnel office employees will be given a thorough indoctrination by the EEO Officer, covering all major aspects of the contractor's EEO obligations within thirty days following their reporting for duty with the contractor.

c. All personnel who are engaged in direct recruitment for the project will be instructed by the EEO Officer in the contractor's procedures for locating and hiring minorities and women.

d. Notices and posters setting forth the contractor's EEO policy will be placed in areas readily accessible to employees, applicants for employment and potential employees.

e. The contractor's EEO policy and the procedures to implement such policy will be brought to the attention of employees by means of meetings, employee handbooks, or other appropriate means.

**4. Recruitment:** When advertising for employees, the contractor will include in all advertisements for employees the notation: "An Equal Opportunity Employer." All such advertisements will be placed in publications having a large circulation among minorities and women in the area from which the project work force would normally be derived.

a. The contractor will, unless precluded by a valid bargaining agreement, conduct systematic and direct recruitment through public and private employee referral sources likely to yield qualified minorities and women. To meet this requirement, the contractor will identify sources of potential minority group employees, and establish with such identified sources procedures whereby minority and women applicants may be referred to the contractor for employment consideration.

b. In the event the contractor has a valid bargaining agreement providing for exclusive hiring hall referrals, the contractor is expected to observe the provisions of that agreement to the extent that the system meets the contractor's compliance with EEO contract provisions. Where implementation of such an agreement has the effect of discriminating against minorities or women, or obligates the contractor to do the same, such implementation violates Federal nondiscrimination provisions.

c. The contractor will encourage its present employees to refer minorities and women as applicants for employment. Information and procedures with regard to referring such applicants will be discussed with employees.

**5. Personnel Actions:** Wages, working conditions, and employee benefits shall be established and administered, and personnel actions of every type, including hiring, upgrading, promotion, transfer, demotion, layoff, and termination, shall be taken without regard to race, color, religion, sex, national origin, age or disability. The following procedures shall be followed:

a. The contractor will conduct periodic inspections of project sites to insure that working conditions and employee facilities do not indicate discriminatory treatment of project site personnel.

b. The contractor will periodically evaluate the spread of wages paid within each classification to determine any evidence of discriminatory wage practices.

c. The contractor will periodically review selected personnel actions in depth to determine whether there is evidence of discrimination. Where evidence is found, the contractor will promptly take corrective action. If the review indicates that the discrimination may extend beyond the actions reviewed, such corrective action shall include all affected persons.

d. The contractor will promptly investigate all complaints of alleged discrimination made to the contractor in connection with its obligations under this contract, will attempt to resolve such complaints, and will take appropriate corrective action within a reasonable time. If the investigation indicates that the discrimination may affect persons other than the complainant, such corrective action shall include such other persons. Upon completion of each investigation, the contractor will inform every complainant of all of their avenues of appeal.

**6. Training and Promotion:**

a. The contractor will assist in locating, qualifying, and increasing the skills of minorities and women who are

## EXHIBIT O

### CDBG FEDERAL/LOCAL PROJECT REQUIREMENTS

applicants for employment or current employees. Such efforts should be aimed at developing full journey level status employees in the type of trade or job classification involved.

b. Consistent with the contractor's work force requirements and as permissible under Federal and State regulations, the contractor shall make full use of training programs, i.e., apprenticeship, and on-the-job training programs for the geographical area of contract performance. In the event a special provision for training is provided under this contract, this subparagraph will be superseded as indicated in the special provision. The contracting agency may reserve training positions for persons who receive welfare assistance in accordance with 23 U.S.C. 140(a).

c. The contractor will advise employees and applicants for employment of available training programs and entrance requirements for each.

d. The contractor will periodically review the training and promotion potential of employees who are minorities and women and will encourage eligible employees to apply for such training and promotion.

**7. Unions:** If the contractor relies in whole or in part upon unions as a source of employees, the contractor will use good faith efforts to obtain the cooperation of such unions to increase opportunities for minorities and women. Actions by the contractor, either directly or through a contractor's association acting as agent, will include the procedures set forth below:

a. The contractor will use good faith efforts to develop, in cooperation with the unions, joint training programs aimed toward qualifying more minorities and women for membership in the unions and increasing the skills of minorities and women so that they may qualify for higher paying employment.

b. The contractor will use good faith efforts to incorporate an EEO clause into each union agreement to the end that such union will be contractually bound to refer applicants without regard to their race, color, religion, sex, national origin, age or disability.

c. The contractor is to obtain information as to the referral practices and policies of the labor union except that to the extent such information is within the exclusive possession of the labor union and such labor union refuses to furnish such information to the contractor, the contractor shall so certify to the contracting agency and shall set forth what efforts have been made to obtain such information.

d. In the event the union is unable to provide the contractor with a reasonable flow of referrals within the time limit set forth in the collective bargaining agreement, the contractor will, through independent recruitment efforts, fill the employment vacancies without regard to race, color, religion, sex, national origin, age or disability; making full efforts to obtain qualified and/or qualifiable minorities and women. The failure of a union to provide sufficient referrals (even though it is obligated to provide exclusive referrals under the terms of a collective bargaining agreement) does not relieve the contractor from the requirements of this paragraph. In the event the union referral practice prevents the contractor from meeting the obligations pursuant to Executive Order 11246, as amended, and these special provisions, such contractor shall immediately notify the contracting agency.

**8. Reasonable Accommodation for Applicants / Employees with Disabilities:** The contractor must be familiar

with the requirements for and comply with the Americans with Disabilities Act and all rules and regulations established there under. Employers must provide reasonable accommodation in all employment activities unless to do so would cause an undue hardship.

**9. Selection of Subcontractors, Procurement of Materials and Leasing of Equipment:** The contractor shall not discriminate on the grounds of race, color, religion, sex, national origin, age or disability in the selection and retention of subcontractors, including procurement of materials and leases of equipment. The contractor shall take all necessary and reasonable steps to ensure nondiscrimination in the administration of this contract.

a. The contractor shall notify all potential subcontractors and suppliers and lessors of their EEO obligations under this contract.

b. The contractor will use good faith efforts to ensure subcontractor compliance with their EEO obligations.

#### **10. Assurance Required by 49 CFR 26.13(b):**

a. The requirements of 49 CFR Part 26 and the State DOT's U.S. DOT-approved DBE program are incorporated by reference.

b. The contractor or subcontractor shall not discriminate on the basis of race, color, national origin, or sex in the performance of this contract. The contractor shall carry out applicable requirements of 49 CFR Part 26 in the award and administration of DOT-assisted contracts. Failure by the contractor to carry out these requirements is a material breach of this contract, which may result in the termination of this contract or such other remedy as the contracting agency deems appropriate.

**11. Records and Reports:** The contractor shall keep such records as necessary to document compliance with the EEO requirements. Such records shall be retained for a period of three years following the date of the final payment to the contractor for all contract work and shall be available at reasonable times and places for inspection by authorized representatives of the contracting agency and the FHWA.

a. The records kept by the contractor shall document the following:

(1) The number and work hours of minority and non-minority group members and women employed in each work classification on the project;

(2) The progress and efforts being made in cooperation with unions, when applicable, to increase employment opportunities for minorities and women; and

(3) The progress and efforts being made in locating, hiring, training, qualifying, and upgrading minorities and women;

b. The contractors and subcontractors will submit an annual report to the contracting agency each July for the duration of the project, indicating the number of minority, women, and non-minority group employees currently engaged in each work classification required by the contract work. This information is to be reported on [Form FHWA-1391](#). The staffing data should represent the project work force on board in all or any part of the last payroll period preceding the end of July. If on-the-job training is being required by special provision, the contractor



## EXHIBIT O

### CDBG FEDERAL/LOCAL PROJECT REQUIREMENTS

will be required to collect and report training data. The employment data should reflect the work force on board during all or any part of the last payroll period preceding the end of July.

#### III. NONSEGREGATED FACILITIES

This provision is applicable to all Federal-aid construction contracts and to all related construction subcontracts of \$10,000 or more.

The contractor must ensure that facilities provided for employees are provided in such a manner that segregation on the basis of race, color, religion, sex, or national origin cannot result. The contractor may neither require such segregated use by written or oral policies nor tolerate such use by employee custom. The contractor's obligation extends further to ensure that its employees are not assigned to perform their services at any location, under the contractor's control, where the facilities are segregated. The term "facilities" includes waiting rooms, work areas, restaurants and other eating areas, time clocks, restrooms, washrooms, locker rooms, and other storage or dressing areas, parking lots, drinking fountains, recreation or entertainment areas, transportation, and housing provided for employees. The contractor shall provide separate or single-user restrooms and necessary dressing or sleeping areas to assure privacy between sexes.

#### IV. DAVIS-BACON AND RELATED ACT PROVISIONS

This section is applicable to all Federal-aid construction projects exceeding \$2,000 and to all related subcontracts and lower-tier subcontracts (regardless of subcontract size). The requirements apply to all projects located within the right-of-way of a roadway that is functionally classified as Federal-aid highway. This excludes roadways functionally classified as local roads or rural minor collectors, which are exempt. Contracting agencies may elect to apply these requirements to other projects.

The following provisions are from the U.S. Department of Labor regulations in 29 CFR 5.5 "Contract provisions and related matters" with minor revisions to conform to the FHWA-1273 format and FHWA program requirements.

##### 1. Minimum wages

a. All laborers and mechanics employed or working upon the site of the work, will be paid unconditionally and not less often than once a week, and without subsequent deduction or rebate on any account (except such payroll deductions as are permitted by regulations issued by the Secretary of Labor under the Copeland Act (29 CFR part 3)), the full amount of wages and bona fide fringe benefits (or cash equivalents thereof) due at time of payment computed at rates not less than those contained in the wage determination of the Secretary of Labor which is attached hereto and made a part hereof, regardless of any contractual relationship which may be alleged to exist between the contractor and such laborers and mechanics.

Contributions made or costs reasonably anticipated for bona fide fringe benefits under section 1(b)(2) of the Davis-Bacon Act on behalf of laborers or mechanics are considered wages paid to such laborers or mechanics, subject to the provisions

of paragraph 1.d. of this section; also, regular contributions made or costs incurred for more than a weekly period (but not less often than quarterly) under plans, funds, or programs which cover the particular weekly period, are deemed to be constructively made or incurred during such weekly period. Such laborers and mechanics shall be paid the appropriate wage rate and fringe benefits on the wage determination for the classification of work actually performed, without regard to skill, except as provided in 29 CFR 5.5(a)(4). Laborers or mechanics performing work in more than one classification may be compensated at the rate specified for each classification for the time actually worked therein: Provided, That the employer's payroll records accurately set forth the time spent in each classification in which work is performed. The wage determination (including any additional classification and wage rates conformed under paragraph 1.b. of this section) and the Davis-Bacon poster (WH-1321) shall be posted at all times by the contractor and its subcontractors at the site of the work in a prominent and accessible place where it can be easily seen by the workers.

b.(1) The contracting officer shall require that any class of laborers or mechanics, including helpers, which is not listed in the wage determination and which is to be employed under the contract shall be classified in conformance with the wage determination. The contracting officer shall approve an additional classification and wage rate and fringe benefits therefore only when the following criteria have been met:

(i) The work to be performed by the classification requested is not performed by a classification in the wage determination; and

(ii) The classification is utilized in the area by the construction industry; and

(iii) The proposed wage rate, including any bona fide fringe benefits, bears a reasonable relationship to the wage rates contained in the wage determination.

(2) If the contractor and the laborers and mechanics to be employed in the classification (if known), or their representatives, and the contracting officer agree on the classification and wage rate (including the amount designated for fringe benefits where appropriate), a report of the action taken shall be sent by the contracting officer to the Administrator of the Wage and Hour Division, Employment Standards Administration, U.S. Department of Labor, Washington, DC 20210. The Administrator, or an authorized representative, will approve, modify, or disapprove every additional classification action within 30 days of receipt and so advise the contracting officer or will notify the contracting officer within the 30-day period that additional time is necessary.

(3) In the event the contractor, the laborers or mechanics to be employed in the classification or their representatives, and the contracting officer do not agree on the proposed classification and wage rate (including the amount designated for fringe benefits, where appropriate), the contracting officer shall refer the questions, including the views of all interested parties and the recommendation of the contracting officer, to the Wage and Hour Administrator for determination. The Wage and Hour Administrator, or an authorized representative, will issue a determination within 30 days of receipt and so advise the contracting officer or

## EXHIBIT O

### CDBG FEDERAL/LOCAL PROJECT REQUIREMENTS

will notify the contracting officer within the 30-day period that additional time is necessary.

(4) The wage rate (including fringe benefits where appropriate) determined pursuant to paragraphs 1.b.(2) or 1.b.(3) of this section, shall be paid to all workers performing work in the classification under this contract from the first day on which work is performed in the classification.

c. Whenever the minimum wage rate prescribed in the contract for a class of laborers or mechanics includes a fringe benefit which is not expressed as an hourly rate, the contractor shall either pay the benefit as stated in the wage determination or shall pay another bona fide fringe benefit or an hourly cash equivalent thereof.

d. If the contractor does not make payments to a trustee or other third person, the contractor may consider as part of the wages of any laborer or mechanic the amount of any costs reasonably anticipated in providing bona fide fringe benefits under a plan or program. Provided, That the Secretary of Labor has found, upon the written request of the contractor, that the applicable standards of the Davis-Bacon Act have been met. The Secretary of Labor may require the contractor to set aside in a separate account assets for the meeting of obligations under the plan or program.

#### 2. Withholding

The contracting agency shall upon its own action or upon written request of an authorized representative of the Department of Labor, withhold or cause to be withheld from the contractor under this contract, or any other Federal contract with the same prime contractor, or any other federally-assisted contract subject to Davis-Bacon prevailing wage requirements, which is held by the same prime contractor, so much of the accrued payments or advances as may be considered necessary to pay laborers and mechanics, including apprentices, trainees, and helpers, employed by the contractor or any subcontractor the full amount of wages required by the contract. In the event of failure to pay any laborer or mechanic, including any apprentice, trainee, or helper, employed or working on the site of the work, all or part of the wages required by the contract, the contracting agency may, after written notice to the contractor, take such action as may be necessary to cause the suspension of any further payment, advance, or guarantee of funds until such violations have ceased.

#### 3. Payrolls and basic records

a. Payrolls and basic records relating thereto shall be maintained by the contractor during the course of the work and preserved for a period of three years thereafter for all laborers and mechanics working at the site of the work. Such records shall contain the name, address, and social security number of each such worker, his or her correct classification, hourly rates of wages paid (including rates of contributions or costs anticipated for bona fide fringe benefits or cash equivalents thereof of the types described in section 1(b)(2)(B) of the Davis-Bacon Act), daily and weekly number of hours worked, deductions made and actual wages paid. Whenever the Secretary of Labor has found under 29 CFR 5.5(a)(1)(iv) that the wages of any laborer or mechanic include the amount of any costs reasonably anticipated in providing benefits under a plan or program described in section 1(b)(2)(B) of the Davis-

Bacon Act, the contractor shall maintain records which show that the commitment to provide such benefits is enforceable, that the plan or program is financially responsible, and that the plan or program has been communicated in writing to the laborers or mechanics affected, and records which show the costs anticipated or the actual cost incurred in providing such benefits. Contractors employing apprentices or trainees under approved programs shall maintain written evidence of the registration of apprenticeship programs and certification of trainee programs, the registration of the apprentices and trainees, and the ratios and wage rates prescribed in the applicable programs.

b.(1) The contractor shall submit weekly for each week in which any contract work is performed a copy of all payrolls to the contracting agency. The payrolls submitted shall set out accurately and completely all of the information required to be maintained under 29 CFR 5.5(a)(3)(i), except that full social security numbers and home addresses shall not be included on weekly transmittals. Instead the payrolls shall only need to include an individually identifying number for each employee (e.g., the last four digits of the employee's social security number). The required weekly payroll information may be submitted in any form desired. Optional Form WH-347 is available for this purpose from the Wage and Hour Division Web site at <http://www.dol.gov/esa/whd/forms/wh347instr.htm> or its successor site. The prime contractor is responsible for the submission of copies of payrolls by all subcontractors. Contractors and subcontractors shall maintain the full social security number and current address of each covered worker, and shall provide them upon request to the contracting agency for transmission to the State DOT, the FHWA or the Wage and Hour Division of the Department of Labor for purposes of an investigation or audit of compliance with prevailing wage requirements. It is not a violation of this section for a prime contractor to require a subcontractor to provide addresses and social security numbers to the prime contractor for its own records, without weekly submission to the contracting agency..

(2) Each payroll submitted shall be accompanied by a "Statement of Compliance," signed by the contractor or subcontractor or his or her agent who pays or supervises the payment of the persons employed under the contract and shall certify the following:

(i) That the payroll for the payroll period contains the information required to be provided under §5.5 (a)(3)(ii) of Regulations, 29 CFR part 5, the appropriate information is being maintained under §5.5 (a)(3)(i) of Regulations, 29 CFR part 5, and that such information is correct and complete;

(ii) That each laborer or mechanic (including each helper, apprentice, and trainee) employed on the contract during the payroll period has been paid the full weekly wages earned, without rebate, either directly or indirectly, and that no deductions have been made either directly or indirectly from the full wages earned, other than permissible deductions as set forth in Regulations, 29CFR part 3;

(iii) That each laborer or mechanic has been paid not less than the applicable wage rates and fringe benefits or cash equivalents for the classification of work performed, as specified in the applicable wage determination incorporated into the contract.

## EXHIBIT O

### CDBG FEDERAL/LOCAL PROJECT REQUIREMENTS

(3) The weekly submission of a properly executed certification set forth on the reverse side of Optional Form WH-347 shall satisfy the requirement for submission of the "Statement of Compliance" required by paragraph 3.b.(2) of this section.

(4) The falsification of any of the above certifications may subject the contractor or subcontractor to civil or criminal prosecution under section 1001 of title 18 and section 231 of title 31 of the United States Code.

c. The contractor or subcontractor shall make the records required under paragraph 3.a. of this section available for inspection, copying, or transcription by authorized representatives of the contracting agency, the State DOT, the FHWA, or the Department of Labor, and shall permit such representatives to interview employees during working hours on the job. If the contractor or subcontractor fails to submit the required records or to make them available, the FHWA may, after written notice to the contractor, the contracting agency or the State DOT, take such action as may be necessary to cause the suspension of any further payment, advance, or guarantee of funds. Furthermore, failure to submit the required records upon request or to make such records available may be grounds for debarment action pursuant to 29 CFR 5.12.

#### 4. Apprentices and trainees

##### a. Apprentices (programs of the USDOL).

Apprentices will be permitted to work at less than the predetermined rate for the work they performed when they are employed pursuant to and individually registered in a bona fide apprenticeship program registered with the U.S. Department of Labor, Employment and Training Administration, Office of Apprenticeship Training, Employer and Labor Services, or with a State Apprenticeship Agency recognized by the Office, or if a person is employed in his or her first 90 days of probationary employment as an apprentice in such an apprenticeship program, who is not individually registered in the program, but who has been certified by the Office of Apprenticeship Training, Employer and Labor Services or a State Apprenticeship Agency (where appropriate) to be eligible for probationary employment as an apprentice.

The allowable ratio of apprentices to journeymen on the job site in any craft classification shall not be greater than the ratio permitted to the contractor as to the entire work force under the registered program. Any worker listed on a payroll at an apprentice wage rate, who is not registered or otherwise employed as stated above, shall be paid not less than the applicable wage rate on the wage determination for the classification of work actually performed. In addition, any apprentice performing work on the job site in excess of the ratio permitted under the registered program shall be paid not less than the applicable wage rate on the wage determination for the work actually performed. Where a contractor is performing construction on a project in a locality other than that in which its program is registered, the ratios and wage rates (expressed in percentages of the journeyman's hourly rate) specified in the contractor's or subcontractor's registered program shall be observed.

Every apprentice must be paid at not less than the rate specified in the registered program for the apprentice's level of progress, expressed as a percentage of the journeymen hourly

rate specified in the applicable wage determination. Apprentices shall be paid fringe benefits in accordance with the provisions of the apprenticeship program. If the apprenticeship program does not specify fringe benefits, apprentices must be paid the full amount of fringe benefits listed on the wage determination for the applicable classification. If the Administrator determines that a different practice prevails for the applicable apprentice classification, fringes shall be paid in accordance with that determination.

In the event the Office of Apprenticeship Training, Employer and Labor Services, or a State Apprenticeship Agency recognized by the Office, withdraws approval of an apprenticeship program, the contractor will no longer be permitted to utilize apprentices at less than the applicable predetermined rate for the work performed until an acceptable program is approved.

##### b. Trainees (programs of the USDOL).

Except as provided in 29 CFR 5.16, trainees will not be permitted to work at less than the predetermined rate for the work performed unless they are employed pursuant to and individually registered in a program which has received prior approval, evidenced by formal certification by the U.S. Department of Labor, Employment and Training Administration.

The ratio of trainees to journeymen on the job site shall not be greater than permitted under the plan approved by the Employment and Training Administration.

Every trainee must be paid at not less than the rate specified in the approved program for the trainee's level of progress, expressed as a percentage of the journeyman hourly rate specified in the applicable wage determination. Trainees shall be paid fringe benefits in accordance with the provisions of the trainee program. If the trainee program does not mention fringe benefits, trainees shall be paid the full amount of fringe benefits listed on the wage determination unless the Administrator of the Wage and Hour Division determines that there is an apprenticeship program associated with the corresponding journeyman wage rate on the wage determination which provides for less than full fringe benefits for apprentices. Any employee listed on the payroll at a trainee rate who is not registered and participating in a training plan approved by the Employment and Training Administration shall be paid not less than the applicable wage rate on the wage determination for the classification of work actually performed. In addition, any trainee performing work on the job site in excess of the ratio permitted under the registered program shall be paid not less than the applicable wage rate on the wage determination for the work actually performed.

In the event the Employment and Training Administration withdraws approval of a training program, the contractor will no longer be permitted to utilize trainees at less than the applicable predetermined rate for the work performed until an acceptable program is approved.

c. Equal employment opportunity. The utilization of apprentices, trainees and journeymen under this part shall be in conformity with the equal employment opportunity requirements of Executive Order 11246, as amended, and 29 CFR part 30.

## EXHIBIT O

### CDBG FEDERAL/LOCAL PROJECT REQUIREMENTS

d. Apprentices and Trainees (programs of the U.S. DOT).

Apprentices and trainees working under apprenticeship and skill training programs which have been certified by the Secretary of Transportation as promoting EEO in connection with Federal-aid highway construction programs are not subject to the requirements of paragraph 4 of this Section IV. The straight time hourly wage rates for apprentices and trainees under such programs will be established by the particular programs. The ratio of apprentices and trainees to journeymen shall not be greater than permitted by the terms of the particular program.

**5. Compliance with Copeland Act requirements.** The contractor shall comply with the requirements of 29 CFR part 3, which are incorporated by reference in this contract.

**6. Subcontracts.** The contractor or subcontractor shall insert Form FHWA-1273 in any subcontracts and also require the subcontractors to include Form FHWA-1273 in any lower tier subcontracts. The prime contractor shall be responsible for the compliance by any subcontractor or lower tier subcontractor with all the contract clauses in 29 CFR 5.5.

**7. Contract termination: debarment.** A breach of the contract clauses in 29 CFR 5.5 may be grounds for termination of the contract, and for debarment as a contractor and a subcontractor as provided in 29 CFR 5.12.

**8. Compliance with Davis-Bacon and Related Act requirements.** All rulings and interpretations of the Davis-Bacon and Related Acts contained in 29 CFR parts 1, 3, and 5 are herein incorporated by reference in this contract.

**9. Disputes concerning labor standards.** Disputes arising out of the labor standards provisions of this contract shall not be subject to the general disputes clause of this contract. Such disputes shall be resolved in accordance with the procedures of the Department of Labor set forth in 29 CFR parts 5, 6, and 7. Disputes within the meaning of this clause include disputes between the contractor (or any of its subcontractors) and the contracting agency, the U.S. Department of Labor, or the employees or their representatives.

**10. Certification of eligibility.**

a. By entering into this contract, the contractor certifies that neither it (nor he or she) nor any person or firm who has an interest in the contractor's firm is a person or firm ineligible to be awarded Government contracts by virtue of section 3(a) of the Davis-Bacon Act or 29 CFR 5.12(a)(1).

b. No part of this contract shall be subcontracted to any person or firm ineligible for award of a Government contract by virtue of section 3(a) of the Davis-Bacon Act or 29 CFR 5.12(a)(1).

c. The penalty for making false statements is prescribed in the U.S. Criminal Code, 18 U.S.C. 1001.

**V. CONTRACT WORK HOURS AND SAFETY STANDARDS ACT**

The following clauses apply to any Federal-aid construction contract in an amount in excess of \$100,000 and subject to the overtime provisions of the Contract Work Hours and Safety Standards Act. These clauses shall be inserted in addition to the clauses required by 29 CFR 5.5(a) or 29 CFR 4.6. As used in this paragraph, the terms laborers and mechanics include watchmen and guards.

**1. Overtime requirements.** No contractor or subcontractor contracting for any part of the contract work which may require or involve the employment of laborers or mechanics shall require or permit any such laborer or mechanic in any workweek in which he or she is employed on such work to work in excess of forty hours in such workweek unless such laborer or mechanic receives compensation at a rate not less than one and one-half times the basic rate of pay for all hours worked in excess of forty hours in such workweek.

**2. Violation; liability for unpaid wages; liquidated damages.** In the event of any violation of the clause set forth in paragraph (1.) of this section, the contractor and any subcontractor responsible therefor shall be liable for the unpaid wages. In addition, such contractor and subcontractor shall be liable to the United States (in the case of work done under contract for the District of Columbia or a territory, to such District or to such territory), for liquidated damages. Such liquidated damages shall be computed with respect to each individual laborer or mechanic, including watchmen and guards, employed in violation of the clause set forth in paragraph (1.) of this section, in the sum of \$10 for each calendar day on which such individual was required or permitted to work in excess of the standard workweek of forty hours without payment of the overtime wages required by the clause set forth in paragraph (1.) of this section.

**3. Withholding for unpaid wages and liquidated damages.** The FHWA or the contracting agency shall upon its own action or upon written request of an authorized representative of the Department of Labor withhold or cause to be withheld, from any moneys payable on account of work performed by the contractor or subcontractor under any such contract or any other Federal contract with the same prime contractor, or any other federally-assisted contract subject to the Contract Work Hours and Safety Standards Act, which is held by the same prime contractor, such sums as may be determined to be necessary to satisfy any liabilities of such contractor or subcontractor for unpaid wages and liquidated damages as provided in the clause set forth in paragraph (2.) of this section.

**4. Subcontracts.** The contractor or subcontractor shall insert in any subcontracts the clauses set forth in paragraph (1.) through (4.) of this section and also a clause requiring the subcontractors to include these clauses in any lower tier subcontracts. The prime contractor shall be responsible for compliance by any subcontractor or lower tier subcontractor with the clauses set forth in paragraphs (1.) through (4.) of this section.

**EXHIBIT O**  
**CDBG FEDERAL/LOCAL PROJECT REQUIREMENTS**

**VI. SUBLETTING OR ASSIGNING THE CONTRACT**

This provision is applicable to all Federal-aid construction contracts on the National Highway System.

1. The contractor shall perform with its own organization contract work amounting to not less than 30 percent (or a greater percentage if specified elsewhere in the contract) of the total original contract price, excluding any specialty items designated by the contracting agency. Specialty items may be performed by subcontract and the amount of any such specialty items performed may be deducted from the total original contract price before computing the amount of work required to be performed by the contractor's own organization (23 CFR 635.116).

a. The term "perform work with its own organization" refers to workers employed or leased by the prime contractor, and equipment owned or rented by the prime contractor, with or without operators. Such term does not include employees or equipment of a subcontractor or lower tier subcontractor, agents of the prime contractor, or any other assignees. The term may include payments for the costs of hiring leased employees from an employee leasing firm meeting all relevant Federal and State regulatory requirements. Leased employees may only be included in this term if the prime contractor meets all of the following conditions:

- (1) the prime contractor maintains control over the supervision of the day-to-day activities of the leased employees;
- (2) the prime contractor remains responsible for the quality of the work of the leased employees;
- (3) the prime contractor retains all power to accept or exclude individual employees from work on the project; and
- (4) the prime contractor remains ultimately responsible for the payment of predetermined minimum wages, the submission of payrolls, statements of compliance and all other Federal regulatory requirements.

b. "Specialty Items" shall be construed to be limited to work that requires highly specialized knowledge, abilities, or equipment not ordinarily available in the type of contracting organizations qualified and expected to bid or propose on the contract as a whole and in general are to be limited to minor components of the overall contract.

2. The contract amount upon which the requirements set forth in paragraph (1) of Section VI is computed includes the cost of material and manufactured products which are to be purchased or produced by the contractor under the contract provisions.

3. The contractor shall furnish (a) a competent superintendent or supervisor who is employed by the firm, has full authority to direct performance of the work in accordance with the contract requirements, and is in charge of all construction operations (regardless of who performs the work) and (b) such other of its own organizational resources (supervision, management, and engineering services) as the contracting officer determines is necessary to assure the performance of the contract.

4. No portion of the contract shall be sublet, assigned or otherwise disposed of except with the written consent of the contracting officer, or authorized representative, and such consent when given shall not be construed to relieve the contractor of any responsibility for the fulfillment of the contract. Written consent will be given only after the contracting agency has assured that each subcontract is

evidenced in writing and that it contains all pertinent provisions and requirements of the prime contract.

5. The 30% self-performance requirement of paragraph (1) is not applicable to design-build contracts; however, contracting agencies may establish their own self-performance requirements.

**VII. SAFETY: ACCIDENT PREVENTION**

This provision is applicable to all Federal-aid construction contracts and to all related subcontracts.

1. In the performance of this contract the contractor shall comply with all applicable Federal, State, and local laws governing safety, health, and sanitation (23 CFR 635). The contractor shall provide all safeguards, safety devices and protective equipment and take any other needed actions as it determines, or as the contracting officer may determine, to be reasonably necessary to protect the life and health of employees on the job and the safety of the public and to protect property in connection with the performance of the work covered by the contract.

2. It is a condition of this contract, and shall be made a condition of each subcontract, which the contractor enters into pursuant to this contract, that the contractor and any subcontractor shall not permit any employee, in performance of the contract, to work in surroundings or under conditions which are unsanitary, hazardous or dangerous to his/her health or safety, as determined under construction safety and health standards (29 CFR 1926) promulgated by the Secretary of Labor, in accordance with Section 107 of the Contract Work Hours and Safety Standards Act (40 U.S.C. 3704).

3. Pursuant to 29 CFR 1926.3, it is a condition of this contract that the Secretary of Labor or authorized representative thereof, shall have right of entry to any site of contract performance to inspect or investigate the matter of compliance with the construction safety and health standards and to carry out the duties of the Secretary under Section 107 of the Contract Work Hours and Safety Standards Act (40 U.S.C.3704).

**VIII. FALSE STATEMENTS CONCERNING HIGHWAY PROJECTS**

This provision is applicable to all Federal-aid construction contracts and to all related subcontracts.

In order to assure high quality and durable construction in conformity with approved plans and specifications and a high degree of reliability on statements and representations made by engineers, contractors, suppliers, and workers on Federal-aid highway projects, it is essential that all persons concerned with the project perform their functions as carefully, thoroughly, and honestly as possible. Willful falsification, distortion, or misrepresentation with respect to any facts related to the project is a violation of Federal law. To prevent any misunderstanding regarding the seriousness of these and similar acts, Form FHWA-1022 shall be posted on each Federal-aid highway project (23 CFR 635) in one or more places where it is readily available to all persons concerned with the project:

18 U.S.C. 1020 reads as follows:

## EXHIBIT O

### CDBG FEDERAL/LOCAL PROJECT REQUIREMENTS

"Whoever, being an officer, agent, or employee of the United States, or of any State or Territory, or whoever, whether a person, association, firm, or corporation, knowingly makes any false statement, false representation, or false report as to the character, quality, quantity, or cost of the material used or to be used, or the quantity or quality of the work performed or to be performed, or the cost thereof in connection with the submission of plans, maps, specifications, contracts, or costs of construction on any highway or related project submitted for approval to the Secretary of Transportation; or

Whoever knowingly makes any false statement, false representation, false report or false claim with respect to the character, quality, quantity, or cost of any work performed or to be performed, or materials furnished or to be furnished, in connection with the construction of any highway or related project approved by the Secretary of Transportation; or

Whoever knowingly makes any false statement or false representation as to material fact in any statement, certificate, or report submitted pursuant to provisions of the Federal-aid Roads Act approved July 1, 1916, (39 Stat. 355), as amended and supplemented;

Shall be fined under this title or imprisoned not more than 5 years or both."

#### **IX. IMPLEMENTATION OF CLEAN AIR ACT AND FEDERAL WATER POLLUTION CONTROL ACT**

This provision is applicable to all Federal-aid construction contracts and to all related subcontracts.

By submission of this bid/proposal or the execution of this contract, or subcontract, as appropriate, the bidder, proposer, Federal-aid construction contractor, or subcontractor, as appropriate, will be deemed to have stipulated as follows:

1. That any person who is or will be utilized in the performance of this contract is not prohibited from receiving an award due to a violation of Section 508 of the Clean Water Act or Section 306 of the Clean Air Act.

2. That the contractor agrees to include or cause to be included the requirements of paragraph (1) of this Section X in every subcontract, and further agrees to take such action as the contracting agency may direct as a means of enforcing such requirements.

#### **X. CERTIFICATION REGARDING DEBARMENT, SUSPENSION, INELIGIBILITY AND VOLUNTARY EXCLUSION**

This provision is applicable to all Federal-aid construction contracts, design-build contracts, subcontracts, lower-tier subcontracts, purchase orders, lease agreements, consultant contracts or any other covered transaction requiring FHWA approval or that is estimated to cost \$25,000 or more – as defined in 2 CFR Parts 180 and 1200.

##### **1. Instructions for Certification – First Tier Participants:**

a. By signing and submitting this proposal, the prospective first tier participant is providing the certification set out below.

b. The inability of a person to provide the certification set out below will not necessarily result in denial of participation in this

covered transaction. The prospective first tier participant shall submit an explanation of why it cannot provide the certification set out below. The certification or explanation will be considered in connection with the department or agency's determination whether to enter into this transaction. However, failure of the prospective first tier participant to furnish a certification or an explanation shall disqualify such a person from participation in this transaction.

c. The certification in this clause is a material representation of fact upon which reliance was placed when the contracting agency determined to enter into this transaction. If it is later determined that the prospective participant knowingly rendered an erroneous certification, in addition to other remedies available to the Federal Government, the contracting agency may terminate this transaction for cause of default.

d. The prospective first tier participant shall provide immediate written notice to the contracting agency to whom this proposal is submitted if any time the prospective first tier participant learns that its certification was erroneous when submitted or has become erroneous by reason of changed circumstances.

e. The terms "covered transaction," "debarred," "suspended," "ineligible," "participant," "person," "principal," and "voluntarily excluded," as used in this clause, are defined in 2 CFR Parts 180 and 1200. "First Tier Covered Transactions" refers to any covered transaction between a grantee or subgrantee of Federal funds and a participant (such as the prime or general contract). "Lower Tier Covered Transactions" refers to any covered transaction under a First Tier Covered Transaction (such as subcontracts). "First Tier Participant" refers to the participant who has entered into a covered transaction with a grantee or subgrantee of Federal funds (such as the prime or general contractor). "Lower Tier Participant" refers any participant who has entered into a covered transaction with a First Tier Participant or other Lower Tier Participants (such as subcontractors and suppliers).

f. The prospective first tier participant agrees by submitting this proposal that, should the proposed covered transaction be entered into, it shall not knowingly enter into any lower tier covered transaction with a person who is debarred, suspended, declared ineligible, or voluntarily excluded from participation in this covered transaction, unless authorized by the department or agency entering into this transaction.

g. The prospective first tier participant further agrees by submitting this proposal that it will include the clause titled "Certification Regarding Debarment, Suspension, Ineligibility and Voluntary Exclusion-Lower Tier Covered Transactions," provided by the department or contracting agency, entering into this covered transaction, without modification, in all lower tier covered transactions and in all solicitations for lower tier covered transactions exceeding the \$25,000 threshold.

h. A participant in a covered transaction may rely upon a certification of a prospective participant in a lower tier covered transaction that is not debarred, suspended, ineligible, or voluntarily excluded from the covered transaction, unless it knows that the certification is erroneous. A participant is responsible for ensuring that its principals are not suspended, debarred, or otherwise ineligible to participate in covered transactions. To verify the eligibility of its principals, as well as the eligibility of any lower tier prospective participants, each participant may, but is not required to, check the Excluded Parties List System website (<https://www.epls.gov/>), which is compiled by the General Services Administration.

## EXHIBIT O

### CDBG FEDERAL/LOCAL PROJECT REQUIREMENTS

i. Nothing contained in the foregoing shall be construed to require the establishment of a system of records in order to render in good faith the certification required by this clause. The knowledge and information of the prospective participant is not required to exceed that which is normally possessed by a prudent person in the ordinary course of business dealings.

j. Except for transactions authorized under paragraph (f) of these instructions, if a participant in a covered transaction knowingly enters into a lower tier covered transaction with a person who is suspended, debarred, ineligible, or voluntarily excluded from participation in this transaction, in addition to other remedies available to the Federal Government, the department or agency may terminate this transaction for cause or default.

\* \* \* \* \*

#### **2. Certification Regarding Debarment, Suspension, Ineligibility and Voluntary Exclusion – First Tier Participants:**

a. The prospective first tier participant certifies to the best of its knowledge and belief, that it and its principals:

(1) Are not presently debarred, suspended, proposed for debarment, declared ineligible, or voluntarily excluded from participating in covered transactions by any Federal department or agency;

(2) Have not within a three-year period preceding this proposal been convicted of or had a civil judgment rendered against them for commission of fraud or a criminal offense in connection with obtaining, attempting to obtain, or performing a public (Federal, State or local) transaction or contract under a public transaction; violation of Federal or State antitrust statutes or commission of embezzlement, theft, forgery, bribery, falsification or destruction of records, making false statements, or receiving stolen property;

(3) Are not presently indicted for or otherwise criminally or civilly charged by a governmental entity (Federal, State or local) with commission of any of the offenses enumerated in paragraph (a)(2) of this certification; and

(4) Have not within a three-year period preceding this application/proposal had one or more public transactions (Federal, State or local) terminated for cause or default.

b. Where the prospective participant is unable to certify to any of the statements in this certification, such prospective participant shall attach an explanation to this proposal.

#### **2. Instructions for Certification - Lower Tier Participants:**

(Applicable to all subcontracts, purchase orders and other lower tier transactions requiring prior FHWA approval or estimated to cost \$25,000 or more - 2 CFR Parts 180 and 1200)

a. By signing and submitting this proposal, the prospective lower tier is providing the certification set out below.

b. The certification in this clause is a material representation of fact upon which reliance was placed when this transaction was entered into. If it is later determined that the prospective lower tier participant knowingly rendered an erroneous certification, in addition to other remedies available to the Federal Government, the department, or agency with which

this transaction originated may pursue available remedies, including suspension and/or debarment.

c. The prospective lower tier participant shall provide immediate written notice to the person to which this proposal is submitted if at any time the prospective lower tier participant learns that its certification was erroneous by reason of changed circumstances.

d. The terms "covered transaction," "debarred," "suspended," "ineligible," "participant," "person," "principal," and "voluntarily excluded," as used in this clause, are defined in 2 CFR Parts 180 and 1200. You may contact the person to which this proposal is submitted for assistance in obtaining a copy of those regulations. "First Tier Covered Transactions" refers to any covered transaction between a grantee or sub-grantee of Federal funds and a participant (such as the prime or general contract). "Lower Tier Covered Transactions" refers to any covered transaction under a First Tier Covered Transaction (such as subcontracts). "First Tier Participant" refers to the participant who has entered into a covered transaction with a grantee or sub-grantee of Federal funds (such as the prime or general contractor). "Lower Tier Participant" refers to any participant who has entered into a covered transaction with a First Tier Participant or other Lower Tier Participants (such as subcontractors and suppliers).

e. The prospective lower tier participant agrees by submitting this proposal that, should the proposed covered transaction be entered into, it shall not knowingly enter into any lower tier covered transaction with a person who is debarred, suspended, declared ineligible, or voluntarily excluded from participation in this covered transaction, unless authorized by the department or agency with which this transaction originated.

f. The prospective lower tier participant further agrees by submitting this proposal that it will include this clause titled "Certification Regarding Debarment, Suspension, Ineligibility and Voluntary Exclusion-Lower Tier Covered Transaction," without modification, in all lower tier covered transactions and in all solicitations for lower tier covered transactions exceeding the \$25,000 threshold.

g. A participant in a covered transaction may rely upon a certification of a prospective participant in a lower tier covered transaction that is not debarred, suspended, ineligible, or voluntarily excluded from the covered transaction, unless it knows that the certification is erroneous. A participant is responsible for ensuring that its principals are not suspended, debarred, or otherwise ineligible to participate in covered transactions. To verify the eligibility of its principals, as well as the eligibility of any lower tier prospective participants, each participant may, but is not required to, check the Excluded Parties List System website (<https://www.epls.gov/>), which is compiled by the General Services Administration.

h. Nothing contained in the foregoing shall be construed to require establishment of a system of records in order to render in good faith the certification required by this clause. The knowledge and information of participant is not required to exceed that which is normally possessed by a prudent person in the ordinary course of business dealings.

i. Except for transactions authorized under paragraph e of these instructions, if a participant in a covered transaction knowingly enters into a lower tier covered transaction with a person who is suspended, debarred, ineligible, or voluntarily excluded from participation in this transaction, in addition to other remedies available to the Federal Government, the

**EXHIBIT O**  
**CDBG FEDERAL/LOCAL PROJECT REQUIREMENTS**

department or agency with which this transaction originated may pursue available remedies, including suspension and/ or debarment.

\* \* \* \* \*

**Certification Regarding Debarment, Suspension, Ineligibility and Voluntary Exclusion--Lower Tier Participants:**

1. The prospective lower tier participant certifies, by submission of this proposal, that neither it nor its principals is presently debarred, suspended, proposed for debarment, declared ineligible, or voluntarily excluded from participating in covered transactions by any Federal department or agency.

2. Where the prospective lower tier participant is unable to certify to any of the statements in this certification, such prospective participant shall attach an explanation to this proposal.

\* \* \* \* \*

**XI. CERTIFICATION REGARDING USE OF CONTRACT FUNDS FOR LOBBYING**

This provision is applicable to all Federal-aid construction contracts and to all related subcontracts which exceed \$100,000 (49 CFR 20).

1. The prospective participant certifies, by signing and submitting this bid or proposal, to the best of his or her knowledge and belief, that:

a. No Federal appropriated funds have been paid or will be paid, by or on behalf of the undersigned, to any person for influencing or attempting to influence an officer or employee of any Federal agency, a Member of Congress, an officer or employee of Congress, or an employee of a Member of Congress in connection with the awarding of any Federal contract, the making of any Federal grant, the making of any Federal loan, the entering into of any cooperative agreement, and the extension, continuation, renewal, amendment, or modification of any Federal contract, grant, loan, or cooperative agreement.

b. If any funds other than Federal appropriated funds have been paid or will be paid to any person for influencing or attempting to influence an officer or employee of any Federal agency, a Member of Congress, an officer or employee of Congress, or an employee of a Member of Congress in connection with this Federal contract, grant, loan, or cooperative agreement, the undersigned shall complete and submit Standard Form-LLL, "Disclosure Form to Report Lobbying," in accordance with its instructions.

2. This certification is a material representation of fact upon which reliance was placed when this transaction was made or entered into. Submission of this certification is a prerequisite for making or entering into this transaction imposed by 31 U.S.C. 1352. Any person who fails to file the required certification shall be subject to a civil penalty of not less than \$10,000 and not more than \$100,000 for each such failure.

3. The prospective participant also agrees by submitting its bid or proposal that the participant shall require that the language of this certification be included in all lower tier subcontracts, which exceed \$100,000 and that all such recipients shall certify and disclose accordingly.



**EXHIBIT O**  
**CDBG FEDERAL/LOCAL PROJECT REQUIREMENTS**

**ATTACHMENT A - EMPLOYMENT AND MATERIALS  
PREFERENCE FOR APPALACHIAN DEVELOPMENT  
HIGHWAY SYSTEM OR APPALACHIAN LOCAL ACCESS  
ROAD CONTRACTS**

This provision is applicable to all Federal-aid projects funded under the Appalachian Regional Development Act of 1965.

1. During the performance of this contract, the contractor undertaking to do work which is, or reasonably may be, done as on-site work, shall give preference to qualified persons who regularly reside in the labor area as designated by the DOL wherein the contract work is situated, or the subregion, or the Appalachian counties of the State wherein the contract work is situated, except:

a. To the extent that qualified persons regularly residing in the area are not available.

b. For the reasonable needs of the contractor to employ supervisory or specially experienced personnel necessary to assure an efficient execution of the contract work.

c. For the obligation of the contractor to offer employment to present or former employees as the result of a lawful collective bargaining contract, provided that the number of nonresident persons employed under this subparagraph (1c) shall not exceed 20 percent of the total number of employees employed by the contractor on the contract work, except as provided in subparagraph (4) below.

2. The contractor shall place a job order with the State Employment Service indicating (a) the classifications of the laborers, mechanics and other employees required to perform the contract work, (b) the number of employees required in each classification, (c) the date on which the participant estimates such employees will be required, and (d) any other pertinent information required by the State Employment Service to complete the job order form. The job order may be placed with the State Employment Service in writing or by telephone. If during the course of the contract work, the information submitted by the contractor in the original job order is substantially modified, the participant shall promptly notify the State Employment Service.

3. The contractor shall give full consideration to all qualified job applicants referred to him by the State Employment Service. The contractor is not required to grant employment to any job applicants who, in his opinion, are not qualified to perform the classification of work required.

4. If, within one week following the placing of a job order by the contractor with the State Employment Service, the State Employment Service is unable to refer any qualified job applicants to the contractor, or less than the number requested, the State Employment Service will forward a certificate to the contractor indicating the unavailability of applicants. Such certificate shall be made a part of the contractor's permanent project records. Upon receipt of this certificate, the contractor may employ persons who do not normally reside in the labor area to fill positions covered by the certificate, notwithstanding the provisions of subparagraph (1c) above.

5. The provisions of 23 CFR 633.207(e) allow the contracting agency to provide a contractual preference for the use of mineral resource materials native to the Appalachian region.

6. The contractor shall include the provisions of Sections 1 through 4 of this Attachment A in every subcontract for work which is, or reasonably may be, done as on-site work.

**EXHIBIT O**  
**CDBG FEDERAL/LOCAL PROJECT REQUIREMENTS**

**GEORGIA DEPARTMENT OF TRANSPORTATION**  
**REQUIRED CONTRACT PROVISIONS FEDERAL-AID CONSTRUCTION**

**EFFECTIVE FEBRUARY 5, 2016**

The Cargo Preference Act (CPA) establishes certain requirements for the use of privately owned United States-flag commercial vessels in transporting equipment, materials, and commodities by ocean vessel. Contractors are required to comply with the CPA requirements and 46 CFR 381 and are required to insert the substance of these provisions into any subcontracts issued pursuant to this contract.

**Cargo Preference Act Requirements**

All Federal-aid projects shall comply with 46 CFR 381.7 (a)–(b) as follows:

(a) *Agreement Clauses. Use of United States-flag Vessels:*

(1) Pursuant to Pub. L. 664 (43 U.S.C. 1241(b)) at least 50 percent of any equipment, materials or commodities procured, contracted for or otherwise obtained with funds granted, guaranteed, loaned, or advanced by the U.S. Government under this agreement, and which may be transported by ocean vessel, shall be transported on privately owned United States-flag commercial vessels, if available.

(2) Within 20 days following the date of loading for shipments originating within the United States or within 30 working days following the date of loading for shipments originating outside the United States, a legible copy of a rated, ‘on-board’ commercial ocean bill-of-lading in English for each shipment of cargo described in paragraph (a)(1) of this section shall be furnished to both the Contracting Officer (through the prime contractor in the case of subcontractor bills-of-lading) and to the Division of National Cargo, Office of Market Development, Maritime Administration, Washington, DC 20590.

(b) *Contractor and Subcontractor Clauses. Use of United States-flag vessels:* The contractor agrees—

(1) To utilize privately owned United States-flag commercial vessels to ship at least 50 percent of the Gross tonnage (computed separately for dry bulk carriers, dry cargo liners, and tankers) involved, whenever shipping any equipment, material, or commodities pursuant to this contract, to the extent such vessels are available at fair and reasonable rates for United States-flag commercial vessels.

(2) To furnish within 20 days following the date of loading for shipments originating within the United States or within 30 working days following the date of loading for shipments originating outside the United States, a legible copy of a rated, ‘on-board’ commercial ocean bill-of-lading in English for each shipment of cargo described in paragraph (b) (1) of this section to both the Contracting Officer (through the prime contractor in the case of subcontractor bills-of-lading) and to the Division of National Cargo, Office of Market Development, Maritime Administration, Washington, DC 20590.

(3) To insert the substance of the provisions of this clause in all subcontracts issued pursuant to this contract.

**EXHIBIT O**  
**CDBG FEDERAL/LOCAL PROJECT REQUIREMENTS**

The CPA requirements would be appropriate for oceanic shipments of materials or equipment that is intended for use on a specific Federal-aid project, such as a precast concrete structural members, fabricated structural steel, tunnel boring machines, or large-capacity cranes.

The CPA requirements are not applicable for goods or materials that come into inventories independent of an FHWA funded-contract. For example, the requirements would not apply to shipments of Portland cement, asphalt cement, or aggregates, as industry suppliers and contractors use these materials to replenish existing inventories. In general, most of the materials used for highway construction originate from existing inventories and are not acquired solely for a specific Federal-aid project.

A test for whether CPA requirements apply or do not apply to shipped goods or materials would be if the goods or materials are what one would consider to be common inventory supplies for highway construction contractor, then CPA would **not apply**. If the materials or goods are considered to be supplies one would consider to be not common supplies of a highway construction contractor then CPA would **apply**.

**EXHIBIT O**  
**CDBG FEDERAL/LOCAL PROJECT REQUIREMENTS**

First Use Date: October 18, 2013

**SPECIAL PROVISION**

**Required Contract Provisions**  
**Federal-Aid Construction Contracts**

---

1. *Subsection I.4 Selection of Labor; Delete the last sentence in the paragraph.*
2. *Subsections IV Davis Bacon and Related Act Provisions; Delete the first paragraph in its entirety and substitute the following:*  
“This section is applicable to all Federal-aid construction projects exceeding \$2,000 and to all related subcontracts. The requirements apply to all projects located within the right-of-way of a roadway.”

**EXHIBIT O**  
**CDBG FEDERAL/LOCAL PROJECT REQUIREMENTS**

12-15-2008

APPENDIX A  
NOTICE TO CONTRACTORS  
COMPLIANCE WITH TITLE VI OF THE CIVIL RIGHTS ACT OF 1964  
FOR  
FEDERAL-AID CONTRACTS

During the performance of this Contract, the Contractor, for itself, its assignees, and successors in interest (hereinafter referred to as the “Contractor”), agrees as follows:

1. Compliance with Regulations: The Contractor will comply with the Regulations of the Department of Transportation relative to nondiscrimination in Federally-assisted programs of the Department of Transportation (Title 49, Code of Federal Regulations, Part 21, hereinafter referred to as the “Regulations”), which are herein incorporated by reference and made a part of the Contract.
2. Nondiscrimination: The Contractor, with regard to the work performed by it afterward and prior to completion of the contract work, will not discriminate on the ground of race, color, national origin, disability, sex, or age in the selection and retention of subcontracts including procurements of materials and leases of equipment. This will be done in accordance with Title VI of the Civil Rights Act of 1964 and other Non-Discrimination Authorities i.e., Section 504 of the 1973 Rehabilitation Act, the 1973 Federal-Aid Highway Act, the 1975 Age Discrimination Act, and the Americans with Disabilities Act of 1990. The Contractor will not participate either directly or indirectly in the discrimination prohibited by Section 21.5 of the Regulations, including employment practices when contract covers a program set forth in Appendix B of the Regulations. In addition, the Contractor will not participate either directly or indirectly in discrimination prohibited by 23 CFR 710.405 (b).
3. Solicitations for subcontracts, including procurements of materials and equipment: In all solicitations, either by competitive bidding or negotiation made by the Contractor for work to be performed under a subcontract, including procurements of materials or equipment, each potential subcontractor or supplier shall be notified by the Contractor of the Contractor’s obligations under this Contract and the Regulations relative to nondiscrimination on the ground of race, color, national origin, disability, sex or age.

A-1

**EXHIBIT O**  
**CDBG FEDERAL/LOCAL PROJECT REQUIREMENTS**

4. Information and Reports: The Contractor will provide all information and reports required by the Regulations, or orders and instructions issued pursuant thereto, and will permit access to its books, records, accounts, other sources of information, and its facilities as may be determined by the Department of Transportation or the Federal Highway Administration to be pertinent to ascertain compliance with such Regulations, orders and instructions. Where any information required of a Contractor is in the exclusive possession of another who fails or refuses to furnish this information, the Contractor shall so certify to the Department of Transportation, or the Federal Highway Administration as appropriate, and shall set forth what efforts it has made to obtain the information.

5. Sanctions for Noncompliance: In the event of the Contractor's noncompliance with the nondiscrimination provisions of this Contract, the Department of Transportation shall impose such Contract sanctions as it or the Federal Highway Administration may determine to be appropriate, including, but not limited to:

- (a) withholding of payments to the Contractors under the Contract until the Contractor complies, and/or
- (b) Cancellation, termination or suspension of the Contract, in whole or in part.

6. Incorporation of Provisions: The Contractor will include the provisions of paragraph (1) through (6) in every subcontract, including procurements of materials and leases of equipment, unless exempt by the Regulations, orders or instruction issued pursuant thereto. The Contractor will take such action with respect to any subcontract or procurement as the Department of Transportation or the Federal Highway Administration may direct as a means of enforcing such provisions including sanctions for noncompliance. Provided, however, that in the event a Contractor becomes involved in, or is threatened with, litigation with a subcontractor or supplier as result of such direction, the Contractor may request the State to enter into such litigation to protect the interests of the State, and, in addition, the Contractor may request the United States to enter into such litigation to protect the interest of the United States.

**EXHIBIT O**  
**CDBG FEDERAL/LOCAL PROJECT REQUIREMENTS**  
**DEPARTMENT OF TRANSPORTATION**  
**STATE OF GEORGIA**

---

**STANDARD FEDERAL EQUAL EMPLOYMENT OPPORTUNITY CONSTRUCTION  
CONTRACT SPECIFICATIONS (EXECUTIVE ORDER 11246) (43 FR 14895)**

1. As used in these specifications:
  - a. "Covered area" means the geographical area described in the solicitation from which this contract resulted;
  - b. "Director" means Director, Office of Federal Contract Compliance Programs, United States Department of Labor, or any person to whom the Director delegated authority;
  - c. "Employer Identification Number" means the Federal Social Security number used on the Employer's Quarterly Federal Tax Return, U.S. Treasury Department Form 941.
  - d. "Minority" includes:
    - (i) Black (all persons having origins in any of the Black African racial groups not of Hispanic origin);
    - (ii) Hispanic (all persons of Mexican, Puerto Rican, Cuban, Central or South American or other Spanish Culture or origin, regardless of race);
    - (iii) Asian and Pacific Islander (all persons having origins in any of the original peoples of the Far East, Southeast Asia, the Indian Subcontinent, or the Pacific Islands); and
    - (iv) American Indian or Alaskan Native (all persons having origins in any of the original peoples of North America and maintaining identifiable tribal affiliations through membership and participation or community identification).
2. Whenever the Contractor, or any Subcontractor at any tier, subcontracts a portion of the work involving any construction trade, it shall physically include in each subcontract in excess of \$10,000 the provisions of these specifications and the Notice which contains the applicable goals for minority and female participation and which is set forth in the solicitations from which this contract resulted.
3. If the Contractor is participating (pursuant to 41 CFR 60-4.5) in a Hometown Plan approved by the U.S. Department of Labor in the covered area either individually or through an association, its affirmative action obligations on all work in the Plan area (including goals and timetables) shall be in accordance with that Plan for those trades which have unions participating in the Plan. Contractors must be able to demonstrate their participation in and compliance with the provisions of any such Hometown Plan. Each Contractor or Subcontractor participating in an approved Plan is individually required to comply with its obligations under the EEO clause, and to make a good faith effort to achieve each goal under the Plan in each trade in which it has employees. The overall good faith performance by other Contractors or Subcontractors toward a goal in an approved Plan does not excuse any covered Contractor's or Subcontractor's failure to take good faith efforts to achieve the Plan goals and timetables.
4. The Contractor shall implement the specific affirmative action standards provided in paragraphs 7a through p of these specifications. The goals set forth in the solicitation from which this contract resulted are expressed as percentages of the total hours of employment and training of minority and female utilization the Contractor should reasonably be able to achieve in each construction trade in which it has employees in the covered area. The Contractor is expected to make substantially uniform progress toward its goals in each craft during the period specified.

**EXHIBIT O**  
**CDBG FEDERAL/LOCAL PROJECT REQUIREMENTS**  
**DEPARTMENT OF TRANSPORTATION**  
**STATE OF GEORGIA**

---

5. Neither the provisions of any collective bargaining agreement, nor the failure by a union with whom the Contractor has a collective bargaining agreement, to refer either minorities or women shall excuse the Contractor's obligations under these specifications, Executive Order 11246, nor the regulations promulgated pursuant thereto.
6. In order for the non-working training hours of apprentices and trainees to be counted in meeting the goals, such apprentices and trainees must be employed by the Contractor during the training period, and the Contractor must have made a commitment to employ the apprentices and trainees at the completion of their training, subject to the availability of employment opportunities. Trainees must be trained pursuant to training programs approved by the U.S. Department of Labor.
7. The Contractor shall take specific affirmative actions to ensure equal employment opportunity. The evaluation of the Contractor's compliance with these specifications shall be based upon its effort to achieve maximum results from its actions. The Contractor shall document these efforts fully, and shall implement affirmative action steps at least as extensive as the following:
  - a. Ensure and maintain a working environment free of harassment, intimidation, and coercion at all sites, and in all facilities at which the Contractor's employees are assigned to work. The Contractor, where possible, will assign two or more women to each construction project. The Contractor shall specifically ensure that all foremen, superintendents, and other on-site supervisory personnel are aware of and carry out the Contractor's obligation to maintain such a working environment, with specific attention to minority or female individuals working at such sites or in such facilities.
  - b. Establish and maintain a current list of minority and female recruitment sources, provide written notification to minority and female recruitment sources and to community organizations when the Contractor or its unions have employment opportunities available, and maintain a record of the organization's responses.
  - c. Maintain a current file of the names, addresses and telephone numbers of each minority and female off-the-street applicant and minority or female referral from a union, a recruitment source or community organization and of what action was taken with respect to each such individual. If such individual was sent to the union hiring hall for referral and was not referred back to the Contractor by the union or, if referred, not employed by the Contractor, this shall be documented in the file with the reason therefore, along with whatever additional actions the Contractor may have taken.
  - d. Provide immediate written notification to the Director when the union or unions with which the Contractor has a collective bargaining agreement has not referred to the Contractor a minority person or woman sent by the Contractor, or when the Contractor has other information that the union referral process has impeded the Contractor's efforts to meet its obligations.
  - e. Develop on-the-job training opportunities and/or participate in training programs for the area which expressly include minority and women, including upgrading programs and apprenticeship and trainee programs relevant to the Contractor's employment needs, especially those programs funded or approved by the Department of Labor. The Contractor shall provide notice of these programs to the sources compiled under 7b above.
  - f. Disseminate the Contractor's EEO policy by providing the notice of the policy to unions and training programs and requesting their cooperation in assisting the Contractor in meeting its EEO obligations; by including it in any policy manual and collective bargaining agreement; by publicizing it in the company newspaper, annual report, etc.; by specific review of the policy with all management personnel and with all minority and female employees at least once a year, and by posting the company EEO policy on bulletin boards accessible to all employees at each location where construction work is performed.



**EXHIBIT O**  
**CDBG FEDERAL/LOCAL PROJECT REQUIREMENTS**

**DEPARTMENT OF TRANSPORTATION**  
**STATE OF GEORGIA**

---

- g. Review, at least annually, the company's EEO policy and affirmative action obligations under these specifications with all employees having any responsibility for hiring, assignment, layoff, termination or other employment decisions including specific review of these items with onsite supervisory personnel such as Superintendents, General Foremen, etc. prior to the initiation of construction work at any job site. A written record shall be made and maintained identifying the time and place of these meetings, persons attending, subject matter discussed, and disposition of the subject matter.
  - h. Disseminate the Contractor's EEO policy externally by including it in any advertising in the news media, specifically including minority and female news media, and providing written notification to and discussing the Contractor's EEO policy with other Contractors and Subcontractors with whom the Contractor does or anticipates doing business.
  - i. Direct its recruitment efforts, both oral and written, to minority, female and community organization, to schools with minority and female students and to minority and female recruitment and training organizations serving the Contractor's area and employment needs. Not later than one month prior to the date for the acceptance of applications for apprenticeship or other training by any recruitment source, the Contractor shall send written notification to organizations such as the above, describing the openings, screening procedures, and test to be used in the selection process.
  - j. Encourage present minority and female employees to recruit other minority persons and women and, where reasonable, provide after school, summer and vacation employment to minority and female youth both on the site and in other areas of a Contractor's workforce.
  - k. Validate all tests and other selection requirements where there is an obligation to do so under 41 CFR Part 60-3.
  - l. Conduct, at least annually, an inventory and evaluation of all minority and female personnel for promotional opportunities and encourage these employees to seek or to prepare for, through appropriate training, etc. such opportunities.
  - m. Ensure that seniority practices, job classifications, work assignments and other personnel practices, do not have a discriminatory effect by continually monitoring all personnel and employment related activities to ensure that the EEO policy and the Contractor's obligations under these specifications are being carried out.
  - n. Ensure that all facilities and company activities are non-segregated except that separate or single-user toilet and necessary changing facilities shall be provided to assure privacy between the sexes.
  - o. Document and maintain a record of all solicitations of offers for subcontracts from minority and female construction contractors and suppliers, including circulation of solicitations to minority and female contractor associations and other business associations.
  - p. Conduct a review, at least annually of all supervisors' adherence to and performance under the Contractor's EEO policies and affirmative action obligations.
8. Contractors are encouraged to participate in voluntary associations which assist in fulfilling one or more of their affirmative action obligations (7a through p). The efforts of a contractor association, joint contractor-union, contractor-community, or other similar group of which the contractor is a member and participant, may be asserted as fulfilling any one or more of its obligations under 7a through p of these Specifications provided that the contractor actively participates in the group, makes every effort to assure that the group has a positive impact on the employment of minorities and women in the industry, ensures that the concrete

**EXHIBIT O**  
**CDBG FEDERAL/LOCAL PROJECT REQUIREMENTS**

**DEPARTMENT OF TRANSPORTATION**  
**STATE OF GEORGIA**

---

benefits of the program are reflected in the Contractor's minority and female workforce participation, makes a good faith effort to meet its individual goals and timetables, and can provide access to documentation which demonstrates the effectiveness of actions taken on behalf of the Contractor. The obligation to comply, however, is the Contractor's and failure of such a group to fulfill an obligation shall not be a defense for the Contractor's noncompliance.

9. A single goal for minorities and a separate single goal for women have been established. The Contractor, however, is required to provide equal employment opportunity and to take affirmative action for all minority groups, both male and female, and all women, both minority and non-minority. Consequently, the Contractor may be in violation of the Executive Order if a particular group is employed in a substantially disparate manner (for example, even though the Contractor has achieved its goals for women generally, the Contractor may be in violation of the Executive Order if a specific minority group of women is underutilized).
10. The Contractor shall not use the goals and timetables or affirmative action standards to discriminate against any person because of race, color, religion, sex, or national origin.
11. The Contractor shall not enter into any subcontract with any person or firm debarred from Government contracts pursuant to Executive Order 11246.
12. The Contractor shall carry out such sanctions and penalties for violation of these specifications and of the Equal Opportunity Clause, including suspension, termination and cancellation of existing subcontracts as may be imposed or ordered pursuant to Executive Order 11246, as amended, and its implementing regulations, by the Office of Federal Contract Programs. Any contractor who fails to carry out such sanctions and penalties shall be in violation of these specifications and Executive Order 11246, as amended.
13. The Contractor, in fulfilling its obligations under these specifications, shall implement specific affirmative action steps, at least as extensive as those standards prescribed in paragraph 7 of these specifications, so as to achieve maximum results from its efforts to ensure equal employment opportunity. If the Contractor fails to comply with the requirements of the Executive Order, the implementing regulations, or these specifications, the Director shall proceed in accordance with 41 CFR 60-4.8.
14. The Contractor shall designate a responsible official to monitor all employment related activity to ensure that the company EEO policy is being carried out, to submit reports relating to the provisions hereof as may be required by the Government and to keep records. Records shall at least include for each employee the name, address, telephone numbers, construction trade, union affiliation if any, employee identification number when assigned, social security number, race, sex, status (e.g., mechanic, apprentice, trainee, helper, or laborer), dates of changes in status, hours worked per week in the indicated trade, rate of pay, and locations at which the work was performed. Records shall be maintained in an easily understandable and retrievable form; however, to the degree that existing records satisfy this requirement, contractors shall not be required to maintain separate records.
15. Nothing herein provided shall be construed as a limitation upon the application of other laws which establish different standards of compliance or upon the application of requirements for the hiring of local or other area residents (e.g., those under the Public Works Employment Act of 1977 and the Community Development Block Grant Program).

**EXHIBIT O**  
**CDBG FEDERAL/LOCAL PROJECT REQUIREMENTS**

2/26/09

**FEDERAL REGISTER / VOL. 45, NO. 194 / FRIDAY, OCTOBER 3, 1980 / NOTICES**

NOTICE OF REQUIREMENT FOR AFFIRMATIVE ACTION TO ENSURE EQUAL  
EMPLOYMENT OPPORTUNITY (EXECUTIVE ORDER 11246) (43 FR 14895)

1. The Offeror's or Bidder's attention is called to the "Equal Opportunity Clause" and the "Standard Federal Equal Employment Opportunity Construction Contract Specifications" set forth herein.
2. The goals and timetables for minority and female participation expressed in percentage terms for the Contractor's aggregate workforce in each trade on all construction work in the covered areas, are as follows:

GOALS FOR FEMALE PARTICIPATION

APPENDIX A  
(43 FR 19473)

The following goals and timetables for female utilization shall be included in all Federal and federally assisted construction contracts and subcontracts in excess of \$10,000. The goals are applicable to the contractor's aggregate on-site construction workforce whether or not part of that workforce is performing work on a Federal or federally-assisted construction contract or subcontract. Area covered: Goals for Women apply nationwide.

Goals and timetables

Timetable	Goals (percent)
4-1-78 to 3-31-79	3.1
4-1-79 to 3-31-80	5.0
4-1-80 Until Further Notice	6.9

GOALS FOR  
MINORITY PARTICIPATION

Appendix B-80

Until further notice, the following goals for minority utilization in each construction craft and trade shall be included in all Federal or federally assisted construction contracts and subcontracts in excess of \$10,000 to be performed in the respective geographical areas. The goals are applicable to each nonexempt contractor's total onsite construction workforce, regardless of whether or not part of that workforce is performing work on a Federal, federally assisted or non-federally related project, contract or subcontract.

**EXHIBIT O**  
**CDBG FEDERAL/LOCAL PROJECT REQUIREMENTS**  
**FEDERAL REGISTER / VOL. 45, NO. 194 / FRIDAY, OCTOBER 3, 1980 / NOTICES**

Construction contractors which are participating in an approved Hometown Plan (see 41 CFR 60-4-5) are required to comply with the goals of the Hometown Plan with regard to construction work they perform in the areas covered by the Hometown Plan. With regard to all their other covered construction work, such contractors are required to comply with the applicable SMSA or EA goal contained in this appendix B-80.

FEDERAL REGISTER / VOL. 45, NO. 194 / FRIDAY, OCTOBER 3, 1980 / NOTICES

State	Goal (percent)
Georgia:	
035 Augusta, GA:	
SMSA Counties:	
0600 Augusta, GA-SC.....	27.2
GA Columbia; GA Richmond, SC Aiken;	
Non-SMSA Counties.....	
GA Burke; GA Emanuel; GA Glascock; GA Jefferson; GA Jenkins; GA Lincoln; GA McDuffie, GA Talferro; GA Warren; GA Wilkes; SC Allendale; SC Bamberg; SC Barnwell; SC Edgefield; SC McCormick;	
36 Atlanta, GA:	
SMSA Counties:	
0520 Atlanta, GA .....	21.2
GA Butts; GA Cherokee; GA Clayton; GA Cobb; GA DeKalb; GA Douglas; GA Fayette, GA Forsyth; GA Fulton; GA Gwinnett; GA Henry; GA Newton; GA Paulding; GA Rockdale; GA Walton	
Non-SMSA Counties.....	
GA Banks; GA Barrow; GA Bartow; GA Carroll; GA Clarke; GA Coweta; GA Dawson; GA Elbert; GA Fannin; GA Floyd; GA Franklin; GA Gilmer; GA Gordon; GA Greene; GA Habersham; GA Hall; GA Haralson; GA Hart; GA Heard; GA Jackson; GA Jasper; GA Lamar; GA Lampkin; GA Madison; GA Morgan; GA Oconee, GA Oglethorpe; GA Pickins, GA Pike; GA Polk; GA Rabun; GA Spalding; GA Stephens; GA Towns; GA; Union; GA Upson White	
37 Columbus, GA:	
SMSA Counties:	
1800 Columbus, GA – AL.....	29.6
Al Russell; GA Chattahoochee; GA Columbus	

**EXHIBIT O**  
**CDBG FEDERAL/LOCAL PROJECT REQUIREMENTS**

FEDERAL REGISTER / VOL. 45, NO. 194 / FRIDAY, OCTOBER 3, 1980 / NOTICES

Non-SMSA Counties.....	31.6
Al Chambers; AJ Lee; GA Harris; GA Marion; GA Meriwether; GA Quitman; GA Schley; GA Stewart; GA Sumter; GA Talbot; GA Troup; GA Webster	
38 Macon, GA:	
SMSA Counties:	
4680 Macon, GA .....	27.5
GA Bibb; GA Houston; GA Jones; GA Twiggs	
Non-SMSA Counties.....	31.7
GA Baldwin; GA Bleckley; Crawford; GA Crisp; GA Dodge; GA Dooly; GA Hancock; GA Johnson; GA Laurens; GA Macon; GA Monroe; GA Peach; GA Pulaski; GA Putman; GA Taylor; GA Telfair; GA Treutlan; GA Washington; GA Wheeler; GA Wilcox; GA Wilkinson	
39 Savannah, GA:	
SMSA Counties:	
7520 Savannah, GA.....	30.6
GA Bryan; GA Chatham; GA Effingham	
Non-SMSA Counties.....	29.8
GA Appling; GA Atkinson; GA Bacon, GA Bulloch; GA Candler; GA Coffee; GA Evans; GA Jeff Davis; GA Liberty; GA Long; GA McIntosh; GA Montgomery; GA Screven; GA Tattnall; GA Toombs; GA Wayne; SC Beaufort; SC Hampton; SC Jasper	
40 Albany, GA:	
SMSA Counties:	
0120 Albany, GA .....	32.1
GA Dougherty; GA Lee	
Non-SMSA Counties.....	31.1
GA Baker; GA Ben Hill; GA Berrien; GA Brooks; GA Calhoun; GA Clay; GA Clinch; GA Colquitt; GA Cook; GA Decatur; GA Early; GA Echols; GA Grady; GA Irwin; GA Lanier; GA Lowndes; GA Miller; GA Mitchell; GA Randolph; GA Seminole; GA Terrell; GA Thomas; GA Tift; GA Turner; GA Worth	
Florida:	
41 Jacksonville FL:	
Non-SMSA Counties.....	22.2
GA Brantley; GA Camden; GA Charlton; GA Glynn; GA Pierce; GA Ware	

**EXHIBIT O  
CDBG FEDERAL/LOCAL PROJECT REQUIREMENTS**

**Revised: December 7, 2009  
Revised: October 21, 2013  
Revised: November 3, 2014**

**DEPARTMENT OF TRANSPORTATION  
STATE OF GEORGIA  
DISADVANTAGED BUSINESS ENTERPRISE PROGRAM  
CRITERIA FOR ACCEPTABILITY**

The purpose of this special provision is to establish criteria for acceptability of DBE firms for work performed on this contract. The intent is to ensure all participation counted toward fulfillment of the DBE goals is (1) real and substantial, (2) performed by viable, independent DBE owned firms, and (3) in accordance with the spirit of the applicable laws and regulations.

The policy of the Georgia Department of Transportation is to ensure compliance with Title VI of the Civil Rights Act of 1964, 49 Code of Federal Regulations, Part 26 and related statutes and regulations in all program activities.

To this end the Georgia Department of Transportation shall not discriminate on the basis of race, color, sex or national origin in the award, administration and performance of any Georgia Department of Transportation assisted contract or in the administration of its Disadvantaged Business Enterprise Program. The Georgia Department of Transportation shall take all necessary and reasonable steps to ensure nondiscrimination.

DBE payments and commitments for Federal-aid projects shall be separate and distinct and cannot be transferred or combined in any matter.

The DBE Goal specified in the contract will be a percentage representing the DBE Race Conscious Participation. The Contractor will strive to achieve an additional percentage in his/her contracts for all projects during the course of the current State Fiscal Year, in order to meet the overall Georgia Department of Transportation DBE goal.

**EXHIBIT O**  
**CDBG FEDERAL/LOCAL PROJECT REQUIREMENTS**

**DBE DIRECTORY:** The Department has available a directory or source list to facilitate identifying DBEs with capabilities relevant to general contracting requirements and to particular solicitations. The Department will make the directory available to bidders and proposers in their efforts to meet the DBE requirements. The directory or listing includes firms which the Department has certified to be eligible DBEs in accordance with 49 CFR Part 26.

**GOAL FOR PARTICIPATION:** If a percentage goal for DBE participation in this contract is set forth elsewhere in this proposal, the Contractor shall complete the DBE GOALS Form included in the proposal. The Contractor is encouraged to make every effort to achieve the goal set by the Department. However, if the Contractor cannot find sufficient DBE participants to meet the goal established by the Department, the Department will consider for award a proposal with less participation than the established goal if:

(A) The bidder can demonstrate no greater participation could be obtained. This should be well documented by demonstrating the Contractor's actions through good faith efforts. The following is a list of types of actions which the Department will consider as part of the Contractor's good faith efforts to obtain DBE participation. This is not intended to be a mandatory checklist nor intended to be exclusive or exhaustive. Other factors or types of efforts may be relevant in appropriate cases.

- (1) Soliciting through all reasonable and available means (e.g. attendance at pre-bid meetings, advertising and/or written notices) the interest of all certified DBEs who have the capability to perform the work of the contract. The Contractor must solicit this interest within sufficient time to allow the DBEs to respond to the solicitation. The Contractor must determine with certainty if the DBEs are interested by taking appropriate steps to follow up initial solicitations.
- (2) Selecting portions of the work to be performed by DBEs to increase the likelihood the DBE goals will be achieved. This includes, where appropriate, breaking out contract work items into economically feasible units to facilitate DBE participation, even when the Contractor might otherwise prefer to perform these work items with its own forces.

**EXHIBIT O**  
**CDBG FEDERAL/LOCAL PROJECT REQUIREMENTS**

- (3) Providing interested DBEs with adequate information about the plans, specifications, and requirements of the contract in a timely manner to assist DBEs participants in responding to a solicitation.
- (4) (a) Negotiating in good faith with interested DBEs.
- Contractor(s) are responsible to make a portion of the work available to DBE subcontractors and suppliers and to select those portions of the work or material needs consistent with the available DBE subcontractors and suppliers, so as to facilitate DBE participation. Evidence of such negotiation includes the names, addresses, and telephone numbers of DBEs that were considered; a description of the information provided regarding the plans and specifications for the work selected for subcontracting; and evidence as to why additional agreements could not be reached for DBEs to perform the work.
- (b) Contractor(s) using good business judgment would consider several factors in negotiating with subcontractors, including DBE subcontractors, and would take a firm's price and capabilities as well as contract goals into consideration. However, the fact there may be some additional costs involved in finding and using DBEs is not in itself sufficient reason for a bidder's failure to meet the contract DBE goal, as long as such costs are reasonable. Also, the ability or desire of a Contractor to perform the work of a contract with its own organization does not relieve the Contractor of the responsibility to make good faith efforts. Contractors are not, however, required to accept higher quotes from DBEs if the price difference is excessive or unreasonable.
- (5) Not rejecting DBEs as being unqualified without sound reasons based on a thorough investigation of their capabilities. The Contractor's standing within its industry, membership in specific groups, organizations, or associations and political or social affiliations (for example union vs. nonunion employee status) are not legitimate causes for the rejection or non-solicitation of bids in the Contractor's efforts to meet the project goal.
- (6) Making efforts to assist interested DBEs in obtaining bonding, lines of credit, or insurance as required by the contractor.



**EXHIBIT O**  
**CDBG FEDERAL/LOCAL PROJECT REQUIREMENTS**

- (7) Making efforts to assist interested DBEs in obtaining necessary equipment, supplies, materials, or related assistance or services.
- (8) Effectively using the services of available minority/women community organizations; minority/women Contractors' groups; local, state, and Federal minority/women business assistance offices; and other organizations as allowed on a case-by-case basis to provide assistance in the recruitment and placement of DBE's.

- (B) The participation proposed by the low bidder is not substantially less than the participation proposed by the other bidders on the same contract.

If no percentage goal is set forth in the proposal, the contractor may enter a proposed DBE participation. This voluntary DBE participation will count as race neutral DBE participation. Prime Contractor shall report race-neutral participation in accordance with the DBE Monthly Report requirements shown in this document.

To be eligible for award of this contract, all bidders will be required to submit the following information to the Department by the close of business on the 3<sup>rd</sup> working day following opening of the bid as a matter of bidder responsibility.

- i. The names and addresses of DBE firms committed to participate in the Contract;
- ii. A description of the work each DBE will perform; The Contractor shall provide information with their bid showing that each DBE listed by the Contractor is certified in the NAICS code(s) for the kind of work the DBE will be performing.
- iii. The dollar amount of participation for each DBE firm participating; Written documentation of the bidder's commitment to use a DBE subcontractor whose participation it submits to meet a contract goal.
- iv. Written confirmation from the DBE committed to participating in the contract, as provided in the prime contractor's commitment.
- v. If the contract goal is not met, evidence of good faith efforts must be provided.

**EXHIBIT O**  
**CDBG FEDERAL/LOCAL PROJECT REQUIREMENTS**

Failure by a bidder to furnish the above information may subject the bid to disqualification. Also failure by the bidder to submit satisfactory evidence of good faith efforts may subject the bid to disqualification.

Award of a contract by the Department to a Prime Contractor who has listed DBE participants with the bid may not constitute final approval by the Department of the listed DBE. The Department reserves the right to approve or disapprove a Disadvantaged firm after a review of the Disadvantaged firm's proposal participation. Payment to the Contractor under the contract may be withheld until final approval of the listed DBEs is granted by the Department.

If the Contractor desires to substitute a DBE in lieu of those listed in the proposal, a letter of concurrence shall be required from the listed DBE prior to approval of the substitution, unless this requirement is waived by the Department.

Agreements between bidder and a DBE in which promises not to provide Subcontracting quotations to other bidders are prohibited.

**DEFINITION:** For the purposes of this provision, the following definitions will apply:

Disadvantaged Business Enterprise or DBE means a for-profit small business concern –

- (1) Ensuring at least 51 percent owned by one or more individuals who are both socially and economically disadvantaged or, in the case of a corporation, in which 51 percent of the stock is owned by one or more such individuals; and
- (2) Whose management and daily business operations are controlled by one or more of the socially and economically disadvantaged individuals who own the business.

Good Faith Efforts means efforts to achieve a DBE goal or other requirement of this part which, by their scope, intensity, and appropriateness to the objective, can reasonably be expected to fulfill the program requirement.

Joint Venture means an association of a DBE firm and one or more other firms to carry out a single, for-profit business enterprise, for which the parties combine their property, capital, efforts, skills and knowledge, and in which the DBE is responsible for a distinct, clearly defined portion of the work of the contract and whose share in the capital contribution, control, management, risks, and profits of the joint venture are commensurate with its ownership interest.

**EXHIBIT O**  
**CDBG FEDERAL/LOCAL PROJECT REQUIREMENTS**

Socially and Economically Disadvantaged Individual means any individual who is a citizen (or lawfully admitted permanent resident) of the United States and who is –

- (1) Any individual who the Department finds to be a socially and economically disadvantaged individual on a case-by-case basis.
- (2) Any individual in the following groups, members of which are reputedly presumed to be socially and economically disadvantaged.
  - (i) “Black Americans,” which includes persons having origins, in any of the Black racial groups of Africa.
  - (ii) “Hispanic Americans,” which includes persons of Mexican, Puerto Rican, Cuban, Dominican, Central or South American, or other Spanish or Portuguese culture or origin, regardless of race.
  - (iii) “Native Americans,” which includes persons who are American Indians, Eskimos, Aleuts, or Native Hawaiians.
  - (iv) “Asian-Pacific Americans,” which includes persons whose origins are from Japan, China, Taiwan, Korea, Burma (Myanmar), Vietnam, Laos, Cambodia (Kampuchea), Thailand, Malaysia, Indonesia, the Philippines, Brunei, Samoa, Guam, the U.S. Trust Territories of the Pacific Islands (Republic of Palau), the Commonwealth of the Northern Marianas Islands, Macao, Fiji, Tonga, Kiribati, Juvalu, Nauru, Federated States of Micronesia, or Hong Kong;
  - (v) “Subcontinent Asian Americans,” which includes persons whose origins are from India, Pakistan, Bangladesh, Bhutan, the Maldives Islands, Nepal or Sri Lanka;
  - (vi) Women;
  - (vii) Any additional groups whose members are designated as socially and economically disadvantaged by the SBA, at such time as the SBA designation becomes effective.
- (3) GDOT will presume that such persons are socially and economically disadvantaged only to the extent permitted by applicable federal law.

Race-conscious measure is one focused specifically on assisting only DBEs, including women- owned

**EXHIBIT O**  
**CDBG FEDERAL/LOCAL PROJECT REQUIREMENTS**

DBEs.

Race-neutral measure is one being, or can be, used to assist all small businesses. For the purposes of this part, race-neutral includes gender-neutrality.

**DISCRIMINATION PROHIBITED:** No person shall be excluded from participation in, denied the benefits of, or otherwise discriminated against in connection with the award and performance of this contract on the grounds of race, color, sex or national origin.

The following assurance becomes a part of this contract and must be included in and made a part of each subcontract the prime contractor enters into with their subcontractors (49 CFR 26.13):  
 “The contractor, and/or subcontractor shall not discriminate on the basis of race, color, national origin, or sex in the performance of this contract. The contractor shall carry out applicable requirements of 49 CFR Part 26 in the award and administration of DOT – assisted contracts. Failure by the contractor to carry out these requirements is (breach) of this contract which may result in the termination of this contract or such other remedy as the Department deems appropriate”.

**Failure to Achieve Requirements:** Periodic reviews shall be made by the Department to determine the extent of compliance with the requirements set forth in this provision. If the Contractor is found to be in noncompliance, further payments for any work performed may be withheld until corrective action is taken. If corrective action is not taken, it may result in termination of this contract. During the life of the contract, the contractor will be expected to demonstrate good faith efforts at goal attainment as provided by 49 CFR 26.

The contractor shall utilize the specific DBEs listed to perform the work and supply the materials for which each is listed unless the contractor obtains the Department’s written consent to substitute and, unless the Department’s consent is provided the contractor shall not be entitled to any payment for work or material unless it is performed or supplied by the listed DBE.

Participation will be counted toward fulfillment of the DBE goal as follows:

- (A) When a DBE participates in a contract, the Contractor counts only the value of the work actually performed by the DBE toward DBE goals.

**EXHIBIT O**  
**CDBG FEDERAL/LOCAL PROJECT REQUIREMENTS**

- (1) Count the entire amount of the portion of a construction contract (or other contract not covered by paragraph (A) (2) of this section) performed by the DBE's own forces. Include the cost of supplies and materials obtained by the DBE for the work of the contract, including supplies purchased or equipment leased by the DBE (except supplies and equipment the DBE subcontractor purchases or leases from the prime contractor or its affiliate).
- (2) Count the entire amount of fees or commissions charged by a DBE firm for providing a bona fide service, such as professional, technical consultant, or managerial services, or for providing bonds or insurance specifically required for the performance of a DOT-assisted contract, toward DBE goals, provided the Department determines the fee is reasonable and not excessive as compared with fees customarily allowed for similar services.
- (3) When a DBE subcontracts part of the work of its contract to another firm, the value of the subcontracted work may be counted toward DBE goals only if the DBE's subcontractor is itself a DBE. Work that a DBE subcontracts to a non-DBE firm does not count toward DBE goals.
- (B) When a DBE performs as a participant in a joint venture, count a portion of the total dollar value of the contract equal to the distinct, clearly defined portion of the work of the contract the DBE performs with own forces toward DBE goals.
- (C) Count expenditures to a DBE contractor toward DBE goals only if the DBE is performing a commercially useful function on that contract.
- (1) A DBE performs a commercially useful function when responsible for execution of the work of the contract and carrying out responsibilities by actually performing, managing, and supervising the work involved. To perform a commercially useful function, the DBE must also be responsible, with respect to materials and supplies used on the contract, for negotiating price, determining quality and quantity, ordering the material, and installing (where applicable) and paying for the material itself.

**EXHIBIT O**  
**CDBG FEDERAL/LOCAL PROJECT REQUIREMENTS**

- (2) A DBE does not perform a commercially useful function if their role is limited to being an extra participant in a transaction, contract, or project through which funds are passed in order to obtain the appearance of DBE participation.
  - (3) If a DBE does not perform or exercise responsibility for at least 30 percent of the total cost of their contract with their own work force, or the DBE subcontracts a greater portion of the work of a contract than would be expected on the basis of normal industry practice for the type of work involved, the Department will presume the DBE is not performing a commercially useful function.
  - (4) When a DBE is presumed not to be performing a commercially useful function as provided in paragraph (C) (3) of this section, the DBE may present evidence to rebut this presumption.
  - (5) The Department's decisions on commercially useful function matters are subject to review by the US DOT but are not administratively appeal-able to the US DOT.
- (D) The following factors are to be used in determining whether a DBE trucking company is performing a commercially useful function:
- (1) The DBE must be responsible for the management and supervision of the entire trucking operation for which they are responsible on a particular contract, and there cannot be a contrived arrangement for the purpose of meeting DBE goals.
  - (2) The DBE must itself own and operate at least one fully licensed, insured, and operational truck used on the contract.
  - (3) The DBE receives credit for the total value of the transportation services it provides on the contract using trucks it owns, insures, and operates using drivers it employs.
  - (4) The DBE may lease trucks from another DBE firm, including an owner/operator who is certified as a DBE. The DBE who leases trucks from another DBE receives credit for the total value of the transportation services the lessee DBE provided on the contract.
  - (5) The DBE may also lease trucks from a non-DBE and is entitled to credit only for the fee or commission it receives because of the lease arrangement. The DBE does not receive credit for the total value of the transportation services provided by the lessee, since these services are not provided by a DBE.

**EXHIBIT O**  
**CDBG FEDERAL/LOCAL PROJECT REQUIREMENTS**

- (6) For purposes of this paragraph (D), a lease must indicate the DBE has exclusive use of and control over the truck. This does not preclude the leased truck from working for others during the term of the lease with the consent of the DBE, so long as the lease gives the DBE absolute priority for use of the leased truck. Leased trucks must display the name and identification number of the DBE.
- (E) Count expenditures with DBEs for materials or supplies toward DBE goals as provided in the following:
- (1) (i) If the materials or supplies are obtained from a DBE manufacturer, count 100 percent of the cost of the materials or supplies toward DBE goals. (ii) For purposes of this paragraph, a manufacturer is a firm that operates or maintains a factory or establishment that produces, on the premises, the materials, supplies, articles, or equipment required under the contract and of the general character described by the specifications.
- (2) (i) If the materials or supplies are obtained from a DBE regular dealer, count 60 percent of the cost of the materials or supplies toward DBE goals. (ii) For purposes of this section, a regular dealer is a firm owning, operating, or maintaining a store, warehouse, or other establishment in which the materials, supplies, articles or equipment of the general character described by the specifications and required under the contract are bought, kept in stock, and regularly sold or leased to the public in the usual course of business.
- (A) To be a regular dealer, the firm must be an established, regular business engaging, as its principal business and under its own name, in the purchase and sale or lease of the products in question.
- (B) A person may be a regular dealer in such bulk items as petroleum products, steel, cement, gravel, stone, or asphalt without owning, operating, or maintaining a place of business as provided in this paragraph **(E)(2)(ii)** if the person both owns and operates distribution equipment for the products. Any supplementing of regular dealers' own distribution equipment shall be by a long-term lease agreement and not

**EXHIBIT O**  
**CDBG FEDERAL/LOCAL PROJECT REQUIREMENTS**

on an ad hoc or contract-by-contract basis.

- (C) Packagers, brokers, manufacturers’ representatives, or other persons who arrange or expedite transactions are not regular dealers within the meaning of this paragraph (E)(2).
- (3) With respect to materials or supplies purchased from a DBE which is neither a manufacturer nor a regular dealer, count the entire amount of fees or commissions charged for assistance in the procurement of the materials and supplies, or fees or transportation charges for the delivery of materials or supplies required on a job site, toward DBE goals, provided you determine the fees to be reasonable and not excessive as compared with fees customarily allowed for similar services. Do not count any portion of the cost of the materials and supplies themselves toward DBE goals, however.
- (4) You must determine the amount of credit awarded to a firm for the provision of materials and supplies (e.g., whether a firm is acting as a regular dealer or a transaction expeditor) on a contract-by-contract basis. Do not count the participation of a DBE subcontractor toward the prime contractor’s DBE achievements until the amount being counted toward the goal has been paid to the DBE.
- (5) No participation will be counted not in compliance with Special Provision entitled “Criteria for Acceptability” which is a part of this contract or with any provisions included in 49 CFR Part 26.
- (6) If the contract amount overruns, the contractor will not be required to increase the dollar amount of DBE participation. If the contract amount under runs, the contractor will not be allowed to under run the dollar amount of DBE participation except when the DBE subcontracted items themselves are under run.

**REPORTS**

- A. The contractor shall submit a “DBE Participation Report” on this contract monthly which shall include the following:



**EXHIBIT O**  
**CDBG FEDERAL/LOCAL PROJECT REQUIREMENTS**

1. The name of each DBE participating in the contract.
  2. A description of the work to be performed, materials, supplies, and services provided by each DBE.
  3. Whether each DBE is a supplier, subcontractor, owner/operator, or other.
  4. The dollar value of each DBE subcontract or supply agreement.
  5. The actual payment to date of each DBE participating in the contract.
  6. The report shall be updated by the Prime Contractor whenever the approved DBE has performed a portion of the work that has been designated for the contract. Copies of this report should be transmitted promptly to the Engineer. Failure to submit the report within 30 calendar days following the end of the month may cause payment to the contractor to be withheld.
  7. The Prime Contractor shall notify the Project Engineer at least 24 hours prior to the time the DBE commences working on the project. The DBE must furnish supervision of the DBE portion of the work, and the person responsible for this supervision must report to the Project Engineer when they begin work on the project. They must also inform the Project Engineer when their forces will be doing work on the project.
- B. To comply with 49 CFR 26.11, the Prime Contractor shall submit documentation regarding all payments made from the Prime to all DBE subcontractors on federal aid projects in the form of copies of canceled checks or notarized electronic documentation which validates said payments made on the DBE Monthly Participation Reports. This information shall be required monthly and submitted with the DBE Monthly Participation Report.
- C. Failure to respond within the time allowed in the request will be grounds for withholding all payments on all Contracts.

**SUBSTITUTION OF DBEs:** The Contractor shall make reasonable efforts to replace a DBE Subcontractor unable to perform work for any reason with another DBE. The Department shall approve all substitutions for Subcontractors in order to ensure the substitute firms are eligible DBEs.

**EXHIBIT O**  
**CDBG FEDERAL/LOCAL PROJECT REQUIREMENTS**

When a DBE subcontractor is terminated or fails to complete its work on the contract for any reason, the prime contractor must make good faith efforts to find another DBE subcontractor to substitute for the original DBE. These good faith efforts shall be directed at finding another DBE to perform at least the same amount of work under the contract as the DBE that was terminated, to the extent needed to meet the contract goal. The good faith efforts shall be documented by the contractor. If the recipient requests documentation under this provision, the contractor shall submit the documentation within 7 days, which may be extended for an additional 7 days if necessary, at the request of the contractor, and the recipient shall provide a written determination to the contractor stating whether or not good faith efforts have been demonstrated.

**CERTIFICATION OF DBEs:** To ensure the DBE Program benefits only firms owned and controlled by Disadvantaged Individuals, the Department shall certify the eligibility of DBEs and joint ventures involving DBEs named by bidders.

Questions concerning DBE Certification/Criteria should be directed to the EEO Office at (404) 631-1972.

**EXHIBIT O**  
**CDBG FEDERAL/LOCAL PROJECT REQUIREMENTS**  
**DEPARTMENT OF TRANSPORTATION**  
**STATE OF GEORGIA**

---

---

First Use 2013 Specifications: November 01, 2013

**SPECIAL PROVISION**

**PROMPT PAYMENT:**

Prime Contractors, who sublet a portion of their work, shall pay their subcontractors for satisfactory performance of their contracts no later than 10 calendar days from receipt of each payment made to them.

Any delay or postponement of payment among the parties may take place only for good cause with prior written approval from the Department.

If the contractor is found to be in noncompliance with these provisions, it shall constitute a breach of contract and further payments for any work performed may be withheld until corrective action is taken. If corrective action is not taken, it may result in termination of the contract.

All subcontract agreements shall contain this requirement.

**EXHIBIT O**  
**CDBG FEDERAL/LOCAL PROJECT REQUIREMENTS**  
**DEPARTMENT OF TRANSPORTATION**  
**STATE OF GEORGIA**

---

**REQUIRED CONTRACT PROVISIONS FOR FEDERAL-AID CONTRACTS**

**BUY AMERICA**

First Use 2013 Specifications: November 1, 2013

All manufacturing processes for steel and iron materials and steel and iron coatings permanently incorporated into this project must occur in the United States of America. However, pig iron and processed, pelletized, or reduced iron ore used in the production of these products may be manufactured outside the United States.

This requirement, however, does not prevent a minimal use of foreign materials and coatings, provided the cost of materials and coatings used does not exceed one-tenth of one percent (0.1 percent) of the total contract cost or \$2,500.00, whichever is greater.

NOTE: Coatings include: epoxy coating, galvanizing, painting and any other coating that protects or enhances the value of the material.

**CONVICT PRODUCED MATERIALS**

First Use 2013 Specifications: November 1, 2013

Materials produced by convict labor after July 1, 1991, may not be used for Federal-Aid highway construction projects unless it meets the following criteria:

1. The materials must be produced by convicts who are on parole, supervised release, or probation from a prison; or,
2. If produced in a qualified prison facility, the amount of such materials produced in any 12-month period shall not exceed the amount produced in such facility for such construction during the 12-month period ending July 1, 1987. A qualified prison is defined as one producing convict made materials prior to July 1, 1987.

**EXHIBIT O**  
**CDBG FEDERAL/LOCAL PROJECT REQUIREMENTS**

First Use Date: January 1, 2007

Revised: March 26, 2008

March 5, 2009

September 30, 2009

August 6, 2012

**DEPARTMENT OF TRANSPORTATION**  
**STATE OF GEORGIA**

**SPECIAL PROVISION**

**Utility Conflicts**

---

Utility companies having known facilities that conflict with the construction of this project will be directed by the Department to adjust or relocate their facilities and will be notified of the contract award.

Conform to all the requirements of the Specifications as they relate to cooperation with utility owners and the protection of utility installations that exist on the project. Refer to the requirements of Section 107, Legal Regulations and Responsibility to the Public, with particular attention to Subsection 107.21.

Coordinate The Work with any work to be performed by others in any right of way clearance and arrange a schedule of operations that will allow for completion of the Project within the specified contract time. Where stage construction is required, notify the utility owner when each stage of work is completed, and the site is available for utility work to proceed.

Information concerning utility facilities known to exist within the project limits, including the list of owners, is available for reference.

Under Georgia Code Section 32-6-171, utilities are required to remove or relocate their facilities. The Department is required to give the utility at least 60 days written notice directing the removal, relocation, or adjustment and the utility owner is required to begin work within the time specified in the utility's work plan or revised work plan.

Upon request, copies of all approved Work Plans submitted by utility companies having facilities on this project will be made available for examination by the Contractor at the Department's District Office. Utility Adjustment Schedules, when submitted to the Department by the utilities, will be made available to the Contractor after the Notice to Contractors has been posted by the Office of Construction Bidding Administration. The Contractor is responsible for considering in its bid all existing and proposed utility locations and the removals, relocations, and adjustments specified in the Utility's Work Plan.

For this Project, Utility Owners that are required to remove, relocate, or adjust their facility to accommodate the construction of this Project may be liable to the Contractor for damages or delay costs resulting from the Utility Owner's failure to clear conflicts.

**EXHIBIT O**  
**CDBG FEDERAL/LOCAL PROJECT REQUIREMENTS**

within the time specified in the approved Utility Work Plan. If the Utility Owner is unable to submit and obtain Department approval of a revised Work Plan or fails to complete the removal, relocation, or adjustment of its facilities in accordance with the approved Work Plan, the Utility Owner may be liable to the Department, or the Contractor, for damages or delay costs.

In accordance with Subsection 105.06 of the Specifications, the Department is not liable for payment of any claims due to utility delays, inconvenience or damage sustained by the Contractor due to interference of any utilities or appurtenances, or the operation of moving them.

In any case in which the Contractor believes that it will be entitled to damages or delay costs from the Utility Owner in accordance with O.C.G.A. 32-6-171, the Contractor shall provide written notice to the Utility Owner and the Department within ten (10) days from the time of the dispute or potential dispute is identified. The Contractor shall follow the Procedures for Utility Damages or Delay Costs outlined in the latest edition of The Utility Accommodation Policy and Standards Manual. Failure to follow the above will result in waiver of the Contractor's claim against the Utility Owner for damages or delay costs.

In accordance with Subsection 107.21.G delays by utilities will continue to be considered by the Department in charging Contract Time. For purposes of applying provisions of this paragraph, railroads, and the Metropolitan Atlanta Rapid Transit Authority (MARTA) are considered utilities.

Office of Utilities

**EXHIBIT O**  
**CDBG FEDERAL/LOCAL PROJECT REQUIREMENTS**

First Use: June 2016

**DEPARTMENT OF**  
**TRANSPORTATION STATE OF**  
**GEORGIA**

**SUPPLEMENTAL SPECIFICATION**

**Section 107 – Legal Regulations and Responsibility to the Public**

---

*Delete Section 107 and Substitute the following:*

**107.01 Laws to Be Observed**

The Contractor shall keep fully informed of all Federal and State laws, all local laws, ordinances, codes, and regulations and all orders and decrees of bodies or tribunals having any jurisdiction or authority, which in any manner affect those engaged or employed on The Work, or which in any way affect the conduct of The Work. The Contractor shall at all times observe and comply with all such laws, ordinances, codes, regulations, orders, decrees, and permits; and shall protect and indemnify the Department and its representatives against any claim or liability arising from or based on the violation of any such law, ordinance, code, regulation, order, decrees, and permits, whether by himself, his employees, subcontractors, or agents.

**107.02 Permits and Licenses**

The Contractor shall procure all permits and licenses, pay all charges, taxes, and fees, and give all notices necessary and incidental to the due and lawful prosecution of The Work.

**107.03 Patented Devices**

If the Contractor employs any design, device, material, or process covered by letters of patent or copyright, he shall provide for such use by suitable legal agreement with the patentee or owner. The Contractor and the Surety shall indemnify and save harmless the Department from any and all claims for infringement by reason of the use of any such patented design, device, material, or process, or any trademark or copyright, and shall indemnify the Department for any costs, expenses, and damages which it may be obliged to pay by reason of any infringement, at any time during the prosecution or after the completion of The Work.

**107.04 Restoration of Surfaces Opened By Permit**

The right to construct or reconstruct any utility service in the highway or street and to grant permits for the same at any time, is expressly reserved by the Department for the proper authorities of the municipality or county in which The Work is done and the Contractor shall not be entitled to any damages either for the digging up of the street or highway, or for any delay occasioned thereby.

Any individual, firm, or corporation wishing to make an opening in the street or highway must secure a permit from the Department. The Contractor shall allow parties bearing such permits, and only those parties, to make openings in the street or highway. When ordered by the Engineer, the Contractor shall make in an acceptable manner all necessary repairs due to such openings and such necessary work will be paid for as Extra Work, or as provided in the Specifications, and will be subject to the same conditions as original work performed.

**107.05 Federal-Aid Provisions**

When the United States Government pays all or any part of the cost of a project, the Federal laws and the rules and regulations made pursuant to such laws must be observed by the Contractor, and The Work shall be subject to the

**EXHIBIT O**  
**CDBG FEDERAL/LOCAL PROJECT REQUIREMENTS**

inspection of the appropriate Federal agency. Such inspection shall in no sense make the Federal Government a party to this Contract and will in no way interfere with the rights of either party hereunder.

### **107.06 Sanitary Provisions**

The Contractor shall provide and maintain in a neat, sanitary condition such accommodations for the use of his employees as may be necessary to comply with the requirements of the State Department of Health and other authorities having jurisdiction and shall permit no public nuisance.

### **107.07 Public Convenience and Safety**

The Contractor shall always so conduct The Work as to assure the least possible obstruction of traffic. The safety and convenience of the public and the residents along the highway and the protection of persons and property shall be provided for by the Contractor as specified under Subsection 104.05, Subsection 107.09, Section 150, the Project Plans, and Special Provisions.

Traffic whose origin and destination are within the limits of the Project shall be provided ingress and egress at all times unless otherwise specified in the Plans or Special Provisions. The ingress and egress include entrance and exit via driveways at the various properties, and access to the intersecting roads and streets. The Contractor shall always maintain sufficient personnel and equipment on the project, particularly during inclement weather, to ensure that ingress and egress are provided when and where needed.

Two-way traffic shall be always maintained at all times unless otherwise specified or approved. The Contractor shall not stop traffic without permission granted by the Engineer.

All equipment used on The Work shall come equipped with factory-installed mufflers, or manufacturer's recommended equivalent, in good condition. These mufflers shall be maintained in good condition throughout the construction period.

### **107.08 Railroad-Highway Provisions**

All work to be performed by the Contractor on a railroad company's right-of-way or property shall be done in a manner satisfactory to the chief engineer of the railroad company, or his authorized representative, and shall be performed at such times and in such manner as not to unnecessarily interfere with the movement of trains or traffic upon the track of the railroad company. The Contractor shall use all reasonable care and precaution to avoid accidents, damage, or unnecessary delay or interference with the railroad company's trains or other property, or property of tenants of railroad company.

The Contractor shall notify the railroad company and obtain its approval before commencing work on the railroad company's right-of-way or property.

The Contractor shall determine what measures are required by the railroad company to protect its operations and right-of-way or property during construction. Such protection may include the use of a flagger or flaggers provided by the railroad company. The Contractor shall be responsible for ensuring that the required protection is provided and shall pay the railroad company directly for any such services which may be required to accomplish the construction unless otherwise specified.

Any temporary grade crossings or other means needed during construction by the Contractor for transporting materials of any nature and/or equipment across the railroad tracks will be the responsibility of the Contractor to handle directly with the railroad company and bear all costs incidental to such crossings including flagging services provided by the railroad company.

A "Special Provisions for the Protection of Railroad Interests" may be included in the proposal to stipulate insurance and other requirements of the railroad company.

### **107.09 Barricades and Danger, Warning, and Detour Signs**

The Contractor shall furnish, install, and maintain all necessary and required barricades, signs, and other traffic control devices in accordance with these Specifications, Project Plans, Special Provisions, and the MUTCD, and take all necessary precautions for the protection of the work and safety of the public.

Unless otherwise specified, all traffic control devices furnished by the Contractor shall remain the property of the Contractor.



**EXHIBIT O**  
**CDBG FEDERAL/LOCAL PROJECT REQUIREMENTS**

**107.10 Forest Protection**

In carrying out work within or adjacent to State or National Forests, or any other forests, parks, or other public or private lands, the Contractor shall obtain necessary permits and comply with all of the regulations of the appropriate authorities having jurisdiction over such forest, park, or lands. The Contractor shall keep the areas in an orderly condition, dispose of all refuse, obtain permits for the construction and maintenance of all construction camps, stores, warehouses, residences, latrines, cesspools, septic tanks, and other structures in accordance with the requirements of the appropriate authority.

The Contractor shall take all reasonable precautions to prevent and suppress forest fires and shall require his employees and subcontractors, both independently and at the request of forest officials, to do all reasonably within their power to prevent and suppress and to assist in preventing and suppressing forest fires; to notify a forest official at the earliest possible moment of the location and extent of any fire seen by them; and to extinguish or aid in extinguishing nearby fires.

**107.11 Construction Over or Adjacent to Navigable Waters****A. Navigation to Be Protected**

Since navigable waterways are under the jurisdiction of the United States Coast Guard and/or the United States Army Corps of Engineers, all work done in, over, on or adjacent to such waters shall comply with their requirements. Free navigation shall not be impeded, and navigable depths shall be maintained.

The Contractor shall comply with permits issued by the United States Coast Guard and/or the United States Army Corps of Engineers, and the Contractor shall obtain and comply with other permits in accordance with the requirements of Subsection 107.02

Special Provisions for environmental protection may be included in the proposal to stipulate environmental commitments and other requirements.

**B. Obstructions to be Removed**

When the construction has progressed enough to permit removal, all falsework, piling and other obstructions shall be removed to the satisfaction of the Federal agency having jurisdiction. In all cases such clearing must be done thoroughly before The Work will be accepted by the Department.

**107.12 Use of Explosives**

When the use of explosives is necessary for the prosecution of The Work, the Contractor shall exercise the utmost care not to endanger life or property, and shall obey all State, Federal and other Governmental regulations applying to transportation, storage, use, and control of such explosives. The Contractor shall be completely responsible for any and all damage resulting from the transportation, storage, use, and control of explosives in the prosecution of The Work by the Contractor, the Contractor's agents, or employees; and shall hold the Department harmless from all claims of damages resulting in any manner therefrom.

The Contractor shall notify each public utility owner having structures or other installations, above or below ground, near the site of The Work of his intention to use explosives. Such notice shall be given sufficiently in advance to enable the utility owners to take such steps as they may deem necessary to protect their property from injury. Such notice shall not relieve the Contractor of responsibility for all damages resulting from his blasting operations.

All explosives shall be stored securely in compliance with all laws and ordinances, and all such storage places shall be clearly marked DANGEROUS EXPLOSIVES. Explosives and detonators shall be stored in separate storage facilities in separate areas. Where no laws or ordinances apply, locked storage shall be provided satisfactory to the Engineer, never closer than 1,000 ft (300 m) from any travel-road, building, or camping area.

In all cases where the transport, storage, or use of explosives is undertaken, such activities shall be controlled and directed by fully qualified representatives of the Contractor.

Whenever electric detonators are used, all radio transmitters shall be turned off within a radius of 500 ft (150 m). No blasting supplies shall be transported in vehicles with two-way radio unless the transmitter is turned off, or extra shielding precautions are taken. Appropriate signs shall be placed so as to give ample warning to anyone driving a vehicle equipped with two-way radio. Electrical detonators will not be used within 500 ft (150 m) of a railroad.

**EXHIBIT O**  
**CDBG FEDERAL/LOCAL PROJECT REQUIREMENTS**

Submit a blasting plan to the Engineer a minimum of five working days prior to use of explosives that provides details of the proposed blasting plan, including, but not limited to, the type and amount of explosives, the shot sequence, the description of and distance to the closest inhabitable structure, and other information as requested by the Engineer. Submission of blasting plan does not relieve the contractor of the responsibility for the adequate and safe performance of the blasting.

### **107.13 Protection and Restoration of Property and Landscape**

#### **A. General Provisions**

The Contractor shall be responsible for the preservation of all public and private property, crops, fish ponds, trees, monuments, highway signs and markers, fences, grassed and sodded areas, etc. along and adjacent to the highway, and shall use every precaution necessary to prevent damage or injury thereto, unless the removal, alteration, or destruction of such property is provided for under the Contract. The Contractor shall use suitable precaution to prevent damage to all underground structures, whether shown on the Plans or not, and shall protect carefully from disturbance or damage, all land monuments and property marks until the Engineer has witnessed or otherwise referenced their location and shall not move them until directed. The Contractor shall not willfully or maliciously injure or destroy trees or shrubs, and he shall not remove or cut them without proper authority.

The Contractor shall be responsible for all sheet piling, shoring, underpinning, etc., as may be required for the protection of abutting property, nearby buildings, streets, and the like.

The Contractor shall be responsible for all damage or injury to property of any character, during the prosecution of The Work, resulting from any act, omission, neglect, or misconduct in his manner or method of executing The Work, or at any time due to defective work or materials, and said responsibility will not be released until the Project shall have been completed and accepted.

When the Contractor's excavating operations encounter remains of prehistoric people's dwelling sites or artifacts of historical or archaeological significance, the operations shall be temporarily discontinued. The Engineer will contact archaeological authorities and the Office of Environmental Services to determine the disposition thereof. When directed by the Engineer, the Contractor shall excavate the site in such a manner as to preserve the artifacts encountered and shall remove them for delivery to the custody of the proper authorities. Such excavation will be considered and paid for as Extra Work.

When the Contractor's normal operations are delayed by such stoppage or extra work, an appropriate time extension will be granted.

The Contractor shall plan, coordinate, and prosecute the work so that disruption to personal property and business is held to a practical minimum.

No resident or business shall be denied vehicular access to their property for any length of time other than as determined by the Engineer is necessary. Where two or more existing driveways are present for a business, only one existing driveway shall be closed at any time. All construction areas abutting lawns and yards of residential or commercial property shall be restored promptly. Backfilling of each drainage structure or section of curb and gutter, sidewalk, or driveway shall be accomplished as soon as adequate strength is obtained. Finishing, dressing, and grassing shall be accomplished immediately thereafter as a continuous operation within each area being constructed with emphasis placed on completing each individual yard or business frontage. Care shall be taken to provide positive drainage to avoid ponding or concentration of runoff.

Handwork, including raking and smoothing, shall be required to ensure that roots, sticks, rocks, and other debris are removed to provide a neat and pleasing appearance. Grassing, when in season, shall immediately follow in order to establish permanent cover at the earliest date. If grassing is not in season, proper erosion control shall be installed and maintained.

The work described above shall be in addition to that required by Subsection 104.07, "Final Cleaning Up" and Subsection 105.16, "Final Inspection and Acceptance".

**EXHIBIT O**  
**CDBG FEDERAL/LOCAL PROJECT REQUIREMENTS**

**B. Erosion and Siltation Control**

The Contractor shall take all necessary measures throughout the life of the Project to control erosion and silting of rivers, streams, and impoundments (lakes, reservoirs, etc.). Construction of drainage facilities as well as performance of other Contract work which will contribute to the control of erosion and siltation shall be carried out in conjunction with clearing and grubbing, and earthwork operations as stipulated in Section 161.

**C. Pollution**

The Contractor shall exercise every reasonable precaution throughout the life of the Contract to prevent pollution of rivers, streams or impoundments. Pollutants such as chemicals, fuels, lubricants, bitumen, raw sewage and other harmful waste shall not be discharged into or alongside rivers, streams, and impoundments, or into natural or man-made channels leading thereto. The Contractor shall also comply with the applicable regulations of other State and Federal departments and to all governmental statutes relating to the prevention and abatement of pollution.

**D. Insect Control Regulations**

The Plant Pest Control Division of the U.S. Department of Agriculture and the Georgia State Department of Agriculture restrict the movement of certain items from areas infested with Japanese Beetles or Imported Fire Ants to prevent the spread of these pests to non-infested areas. Where insect infested areas are shown on the Plans, Contractors will control their operations in such a manner as to comply fully with the requirements of Section 155.

**E. Reclamation of Material Pits and Waste Disposal Areas**

Whenever or wherever the Contractor obtains material from a source or wastes material on an area other than within the Right-of-Way, regardless of the fashion, manner, or circumstances for which the source or area is obtained, it shall be reclaimed in accordance with the requirements of Section 160.

**F. Mailboxes**

The property owner shall have the responsibility for removing and relocating the mailbox to an area outside construction limits.

The Engineer will mark a point for the relocation of the box. The stake should be set so that the location of the box will be convenient to both the mail carrier and the patron, yet not interfering with the proposed work. It may be necessary for the Engineer to confer with the Post Office serving the area.

The Contractor shall notify each affected owner, in writing, that their mailbox is in conflict with the proposed construction, that they have ten days to relocate the box and that, after the expiration of the 10 days' notice, if the owner has not relocated the box, it shall be removed by the Contractor and laid upon the owner's property, clear of the Right-of-Way.

Any cost to the Contractor for removing the mailboxes as stated above shall be included in the price bid for other items.

**G. Failure to Comply**

Failure of the Contractor to comply with any of the above provisions or to install erosion prevention items included in the Contract at the time specified, will be evidence of omission and neglect, and the Contractor will be liable for damages as outlined in Subsection 107.13.H below. Furthermore, the Engineer shall withhold payment on all Contract Items until such time as the Contractor complies in full of all of the aforesaid provisions.

**H. Payment for Damages**

When or where any direct or indirect damage or injury is done to public or private property by or on account of any act, omission, neglect, or misconduct in the execution of the Work, or in consequence of the non-execution thereof by the Contractor, the Contractor shall restore, at his own expense, such property to a condition similar or equal to that existing before such damage or injury was done, by repairing, rebuilding or otherwise restoring as may be directed, or shall make good such damage or injury in an acceptable manner.

**EXHIBIT O**  
**CDBG FEDERAL/LOCAL PROJECT REQUIREMENTS**

**I. Compensation**

All costs pertaining to any requirement contained herein shall be included in the overall Bid submitted unless such requirement is designated as a separate Pay Item in the Proposal.

**107.14 Load Restrictions**

It is hereby agreed between the Department and the Contractor that in the performance of The Work under the Contract, the following load restrictions and stipulations shall be in full force and effect during the life of the Contract:

**A. Parties Affected**

The load restrictions and stipulations contained herein shall be applicable to the equipment of the Contractor; each agent or subcontractor employed by the Contractor; and each person or persons, firm, partnership, corporation, or any combination thereof, hauling materials, supplies or equipment to or on the Project, by or for the Contractor.

**B. Within Project Limits**

No hauling equipment which is loaded beyond those limits provided by State Law shall be permitted on any portion of the new or existing pavement structure except that such loads will be permitted on non-stabilized bases and sub-bases prior to placing roadway paving subject to the provisions of Subsection 107.17.

Axle loads and gross weight limits will be evaluated in accordance with current Georgia Law.

All damage caused by any equipment to any permanent installation or portion of The Work shall be promptly repaired by the Contractor at his expense. When it becomes necessary to cross existing pavement with excessive loads, the Contractor shall provide and remove, at his own expense, proper cushioning by means of earth blanket or otherwise as directed.

**C. Outside Project Limits**

All equipment users included in Subsection 107.14.A, above, operating equipment on roads outside the Project limits shall be governed by the following regulations:

1. No vehicle shall carry any load more than of that specified by Georgia Law.
2. On County System roads the maximum total gross weight shall not exceed 56,000 lbs. (25,400 kg) unless a vehicle is making a pickup or delivery on such roads.
3. For a specific individual trip, the above weight limitations may be exceeded provided a special permit is obtained from the Department for each such movement. A special permit will not relieve the Contractor of liability for damage that may result from such a movement. Refer to O.C.G.A §32-6-26 Weight of Vehicle and Load, SB54 (2011) for compliance with weight limitations and exceptions.
4. Authorized personnel of the Department of Public Safety shall be permitted to weigh each truck hauling material to the Project whenever the Department so desires. The owner of each truck shall instruct his operators to cooperate with and assist the truck weighers in every way possible.
5. A Certified Public Weigher operating under the provisions of Standard Operating Procedure 15 shall not dispatch any vehicle loaded with material to be incorporated into the Project when the gross vehicle weight exceeds the limit established by law.
6. Ready Mix Concrete trucks shall comply with load restrictions as specified in Laboratory Standard Operating Procedure 10, "Quality Assurance for Ready-Mixed Concrete Plants in Georgia."

**D. Responsibilities**

It will be the responsibility of the Contractor to advise his personnel, and all equipment users included in Subsection 107.14.A, as to the load restrictions and stipulations contained herein.

**E. Excess Loads and Violations**

If multiple violations assigned to a given Certified Public Weigher are occurring, that Certified Public Weigher may be suspended from weighing materials dispatched to Department of Transportation projects.

**EXHIBIT O**  
**CDBG FEDERAL/LOCAL PROJECT REQUIREMENTS**

**107.15 Responsibility for Damage Claims**

The Contractor shall indemnify and save harmless the Department, its officers and employees, from all suits, actions, or claims of any character brought because of any injuries or damage received or sustained by any person, persons, or property on account of the operations of the said Contractor; or on account of or in consequence of any neglect in safeguarding The Work; or through use of unacceptable materials in constructing The Work; or because of any act of omission, neglect or misconduct of said Contractor; or because of any claims or amounts recovered from any infringements of patent, trademark, or copyright; or from any claims or amounts arising or recovered under the Workmen's Compensation Act, or any other law, ordinance, order, or decree; and so much of the money due the said Contractor under and by virtue of his Contract as may be considered necessary by the Department for such purpose may be withheld for the use of the State; or, in case no money is due, his surety may be held until such suit or suits, action or actions, claim or claims for injuries or damages as aforesaid shall have been settled and suitable evidence to that effect furnished to the Department; except that money due the Contractor will not be withheld when the Contractor produces satisfactory evidence that he is adequately protected by public liability and property damage insurance.

**107.16 Opening Sections of Project to Traffic**

Whenever any bridge or section of roadway is in acceptable condition for travel, the Engineer may direct that it be opened to traffic, whether or not the opening was originally provided for, and such opening shall not be held to be in any way an acceptance of the bridge or roadway, or any part thereof, or as a waiver of any of the provisions of the Contract. Necessary repairs or renewals made on any section of the roadway or bridge thus opened to traffic under instructions from the Engineer, due to defective material or work, or to any cause other than ordinary wear and tear, pending completion and acceptance of the roadway, bridge, or other work, shall be done by the Contractor, without additional compensation. Also, the Contractor shall not receive additional compensation for completing the Work except as specified in Subsection 104.03.

If the Contractor is dilatory in completing shoulders, drainage structures, or other features of work, the Engineer may so notify him in writing and establish therein a period of time in which the Work should be completed. If the Contractor is dilatory or fails to make a reasonable effort toward completion in this period of time, the Engineer may then order all or a portion of the Project opened to traffic. On such sections which are so ordered to be opened, the Contractor shall conduct the remainder of his construction operations to cause the least obstruction to traffic and shall not receive any added compensation due to the added cost of the Work by reason of opening such section to traffic.

On any section opened to traffic under any of the above conditions, whether stated in the Special Provisions or opened by necessity of Contractor's operations, or unforeseen necessity, any damage to the highway not attributable to traffic which might occur on such section (except slides) shall be repaired by the Contractor at his expense. The removal of slides shall be done by the Contractor on the basis agreed to prior to the removal of such slides.

**107.17 Contractor's Responsibility for the Work**

From the first day the Contractor begins work, or from the date Contract Time commences, whichever occurs first, until written final acceptance of the project by the Engineer, the Contractor shall have the charge and care thereof and shall take every precaution against injury or damage to any part thereof by the action of the elements or from any other cause, whether arising from the execution or from the non-execution of The Work. The Contractor shall rebuild, repair, restore, and make good all injuries or damages to any portion of The Work occasioned by any of the above causes before final acceptance and shall bear the expense thereof except that the Department may, in its discretion, reimburse the Contractor for the repair of damage to The Work due to unforeseeable causes beyond the control of and without the fault or negligence of the Contractor, including but not restricted to acts of God, of the public enemy or of governmental authorities. The Contractor's responsibility for damages and injuries is defined in Subsection 104.05.A.

In case of suspension of work from any cause whatsoever, the Contractor shall be responsible for the Project and shall take such precautions as may be necessary to prevent damage to the Project, provide for normal drainage and shall erect any necessary temporary structures, signs, or other facilities at his expense.

**107.18 Acquisition of Right-of-Way**

Rights of Way for the project will be obtained by the Department, in coordination with local governments and others. However, the Contractor's access to the portions of the right-of-way may be restricted. Where such

**EXHIBIT O**  
**CDBG FEDERAL/LOCAL PROJECT REQUIREMENTS**

restrictions are known in advance to the Department they will be listed in the bid proposal. Delays to the progress of the Work may be encountered because of restricted access to portions of the right-of-way. When such delays occur, whether caused by restrictions listed in the bid proposal or restrictions that develop after the Contract is signed, the parties agree in executing the Contract that such delays do not constitute breach of the Contract. Delays in availability of right-of-way beyond those listed in the bid proposal, or that develop after the Contract has been signed, that impact the controlling Item or Items of the Work will not be charged against the Contract Time. Additional compensation for such delays shall not be paid, except as provided in Subsection 105.13, "Claims for Adjustments and Disputes," or Subsection 109.09, "Termination Clause." In the event the Department is unable to acquire right-of-way needed for the project, resulting in delay to or termination of the project, such situation will also be controlled by this Section, and will not constitute a breach of the Contract by the Department.

**107.19 Personal Liability of Public Officials**

In carrying out any of the provisions of the Contract or in exercising any power or authority granted to the Board, Commissioner, Chief Engineer, their agents and employees, by the Contract, there shall be no liability, either personally or as officials or representatives of the Department, it being understood that in all such matters they act solely as agents and representatives of the Department.

**107.20 No Waiver of Legal Rights**

Upon completion of The Work, the Department will expeditiously make final inspection and notify the Contractor of acceptance. Such final acceptance, however, shall not preclude or stop the Department from correcting any measurement, estimate, or certificate made before or after completion of The Work, nor shall the Department be precluded or stopped from recovering from the Contractor or his Surety, or both, such over-payment as it may sustain, or by failure on the part of the Contractor to fulfill his obligations under the Contract. A waiver on the part of the Department of any breach of any part of the Contract shall not be held to be a waiver of any other or subsequent breach.

The Contractor, without prejudice to the terms of the Contract, shall be liable to the Department for latent defects, fraud, or such gross mistakes as may amount to fraud, or as regards the Department's rights under any warranty or guaranty.

**107.21 General Description**

The Contractor shall designate, prior to beginning any work, a Worksite Utility Coordination Supervisor (WUCS) who shall be responsible for initiating and conducting utility coordination meetings and accurately recording and reporting the progress of utility relocations and adjustment work. Also, the WUCS shall prepare an Emergency Response Plan for the purpose of planning, training, and communicating among the agencies responding to the emergency. The WUCS shall be the primary point of contact between all of the Utility companies, the Contractor and the Department. The WUCS shall recommend the rate of re-occurrence for utility coordination meetings and the Engineer will have the final decision on the regularity for utility coordination meetings. In no case will utility coordination meetings occur less than monthly until controlling items of utility relocations and adjustment milestones are completed. The WUCS shall contact each of the utility companies for the purpose of obtaining information including, but not limited to, a Utility Adjustment Schedule for the controlling items of utility relocations and adjustments. The WUCS shall notify the appropriate utility company and/or utility subcontractors and the Department of the status of controlling items of relocations and adjustment milestones as they are completed. The WUCS shall furnish the Engineer, for approval, a Progress Schedule Chart, immediately following the receipt of the Notice to Proceed unless otherwise specified, which includes the utility companies controlling items of work and other information in accordance with Section 108.03 or elsewhere in the Contract documents.

**A. Qualifications**

The WUCS shall be an employee of the Prime Contractor, shall have at least one year experience directly related to highway and utility construction in a supervisory capacity and have a complete understanding of the Georgia Utilities Protection Center operations, and shall be knowledgeable of the High-voltage Safety Act and shall be trained on the Georgia Utility Facility Protection Act (GUFPA). The Department does not provide any training on GUFPA but will maintain a list of the Georgia Public Service Commission certified training programs developed by other agencies. Currently the following companies offer approved GUFPA training programs:

**EXHIBIT O**  
**CDBG FEDERAL/LOCAL PROJECT REQUIREMENTS**

Associated Damage Consultants  
 Phone: 706.234.8218 or 706.853.1362  
 Georgia Utility Contractors Association  
 Phone: 404.362.9995

Georgia Utilities Protection Center  
 Phone: 678.291.0631 or 404.375.6209  
 H B Training & Consulting  
 Phone: 706.619.1669 or 877.442.4282 (Toll Free)

The Prime Contractor is responsible for obtaining the GUFPA training for their employees. Questions concerning the Georgia Public Service Commission GUFPA training program should be directed to:  
 Georgia Public Service Commission  
 244 Washington St. SW  
 Atlanta, GA 30334-5701  
 404.463.9784

**B. Ticket Status**

During the utility coordination meetings, the WUCS shall collect and maintain the Ticket Status information to determine the status of all locate requests within the project limits. This information will be used to ensure those planning to use mechanized equipment to excavate or work within the project limits are prepared to begin work when they have reported or estimated beginning work. At points where the Contractor's or utility company's operations are adjacent to or conflict with overhead or underground utility facilities, or are adjacent to other property, damage to which might result in considerable expense, loss, or inconvenience, work shall not commence until all arrangements necessary for the protection thereof have been made.

**C. Notice**

The names of known utility companies and the location of known utility facilities will be shown on the Plans, or listed in the Subsurface Utility Engineering Investigation if performed or in the Special Provisions; and the WUCS shall give 24-hour notice to such utility companies before commencing work adjacent to said utility facilities which may result in damage thereto. The WUCS shall further notify utility companies of any changes in the Contractor's work schedules affecting required action by the utility company to protect or adjust their facilities. Notice to the utility companies by the Department of the Award of Contract, under Subsection 105.06, shall not be deemed to satisfy the notice required by this paragraph. Furthermore, this 24-hour notice shall not satisfy or fulfill the requirements of the Contractor as stated in Chapter 9 of Title 25 of the Official Code of Georgia Annotated, known as the "Georgia Utility Facility Protection Act".

**D. Agenda**

The WUCS shall cooperate with the companies of any underground or overhead utility facilities in their removal and relocations or adjustment work in order that these operations may progress in a reasonable manner, that duplication of their removal and relocations or adjustment work may be reduced to a minimum, and services rendered by those parties will not be unnecessarily interrupted. To promote this effort the WUCS shall prepare an agenda for the utility coordination meetings and circulate the same in advance of the meeting to encourage input and participation from all of the utility companies. The agenda will be prepared by an examination of the project site and may include photographs of potential/actual utility conflicts.

**E. Emergency Response Plan**

The WUCS shall prepare an Emergency Utility Response Plan (EURP) within 30 days following the receipt of the Notice to Proceed. The EURP shall indicate the project location (which includes street address and or major intersections / major highway route, if possible with a land mark) that would be reported in case of an emergency, WUCS, Emergency Utility Coordinator (EUC), utility company name, utility company emergency contact information to include but not limited to emergency phone number, response time for emergency, working condition of devices needed to facilitate prompt shut off, and primary point of contact name and phone number for the project.

## EXHIBIT O CDBG FEDERAL/LOCAL PROJECT REQUIREMENTS

Emergency Utility Coordinator (EUC) shall be an employee of the Prime Contractor and shall notify the appropriate utility company and/or utility subcontractors in case of an emergency. EURP must include the contact details of the EUC, if WUCS is not the primary emergency utility coordinator for this project.

The plan will also include a means of reporting emergencies and the Utility Emergency Response Information for each company. The WUCS/EUC shall post the EURP in an area readily accessible to the Department and project personnel. Also, WUCS shall distribute the copies of EURP by e-mail and hard copy to GA DOT Area Engineer, GA DOT Construction Project Engineer, Contractor's project manager, superintendent, and all approved sub-contractors whose work can be in conflict with utilities facilities, personnel of the each facility/owner/ operator who has facilities within the project limits and keep a copy in close proximity to active construction.

In the event of interruption to gas, water, or other utility services as a result of accidental breakage or as a result of being exposed or unsupported, the WUCS/EUC shall promptly notify the appropriate emergency officials, the Georgia Utilities Protection Center and the appropriate utility facility company or operator, if known. Until such time as the damage has been repaired, no person shall engage in excavating or blasting activities that may cause further damage to the utility facility.

To keep up with the latest / most updated EURP contact information (name and phone numbers); WUCS shall include an item in the agenda of Utility Coordination meeting about the updates / changes in the EURP plan.

The Emergency Utility Response Plan and Emergency Utility Response Information template can be found at the State of Georgia, Office of Utilities Web page.

### **F. Submission**

Provisions for reporting all utility coordination meetings, the progress of utility relocation and adjustment work milestones and ticket status information will be reported on a form developed by the WUCS and will be distributed by the WUCS to all of the utility companies as milestones are met and shall be included as part of the project records. These reports shall be delivered to the Engineer for review, monthly. The WUCS shall immediately report to the Engineer any delay between the utility relocation and adjustment work, the existing Utility Adjustment Schedule, or the proposed Utility Adjustment Schedule so that these differences can be reconciled.

### **G. Delays**

Delays and interruptions to the controlling Item or Items of The Work caused by the adjustment or repair of water, gas, or other utility appurtenances and property may be considered for an extension of Contract Time as provided in Subsection 108.07.E unless such delays are due to the negligence of the Contractor.

### **H. Facilities Supported on Bridges**

If the utility facilities are to be supported on bridges, the following provisions shall apply:

1. The Plans will show the location of the facility and the auxiliary items necessary to support the facility. The Contractor constructing the bridge shall install anchor bolts, thimbles, inserts, or other auxiliary items attached to the bridge as a part of the support for the utility facility. The Utility Company shall furnish these auxiliary items, unless the Contract indicates these items are to be furnished by the Contractor as a part of the bridge construction.
2. The Utility or its subcontractor constructing the utility facility shall install hanger rods, pipe rollers, and other attachments necessary for the support of the utility facility as indicated on the Plans. The Utility Company shall furnish these attachments at no cost to the Department or the prime contractor unless otherwise specified. This work shall also include:
  - a. Caulking the openings around the utility where it passes through end walls to prevent the passage of undesirable materials.
  - b. Painting the exposed portions of utility supports unless such supports are corrosion resistant. Painting shall be done in accordance with the applicable portions of Section 535, unless otherwise specified.
4. The sequence of bridge construction work may be set forth in the Plans and/or the Special Provisions and will show at what stage of the Work a utility company will be allowed to do the utility installation. Further, all or any portion of The Work under Subsection 107.21.H.3 may be included in the bridge Contract by the Plans and/or the Special Provisions.



**EXHIBIT O**  
**CDBG FEDERAL/LOCAL PROJECT REQUIREMENTS**

5. Any damage to the bridge structure caused by the utility installation shall be repaired to the satisfaction of the Engineer at the expense of the Utility or its subcontractor installing the utility facility.

**I. Clearances**

The Plans provide for at least minimum clearance of utilities as required by the National Electrical Safety Code, U.S. Department of Commerce, and National Bureau of Standards. Any additional clearance the Contractor may desire or require in performing The Work shall be arranged by the Contractor with the utility company. The Department will pay no extra compensation for such additional clearances.

**J. Utility Relocation Progress Schedule**

The purpose of the Utility Adjustment Schedule is to provide the Contractor with the pertinent information, including any utility staging required, dependent activities, or joint-use coordination that is required for the creation of a feasible progress schedule. A suitable Utility Adjustment Schedule form is available from the Department for the WUCS to circulate to utility companies for any proposed project construction staging or should a utility company not duly file a Utility Adjustment Schedule to the Department during the preconstruction phase of the project. The WUCS shall submit a Utility Relocation Progress Schedule showing together the Progress Schedule Chart referenced in Section 108.03 and the proposed Utility Adjustment Schedules from all utility companies to the Engineer for review and approval. Copies of existing Utility Adjustment Schedules with utility companies having facilities on this project will be made available at the Georgia Department of Transportation, Office of Construction Bidding Administration, located at One Georgia Center, 600 West Peachtree Street, NW, Atlanta, GA 30308, for examination by the Contractor. The Utility Adjustment Schedules are available on-line at: [www.dot.ga.gov/partner\\_smart/contractors/bidding\\_letting/bidx/default.aspx](http://www.dot.ga.gov/partner_smart/contractors/bidding_letting/bidx/default.aspx)

**K. Compensation**

There will be no separate measurement or payment for this Work. The cost associated with this Work shall be included in the overall Bid submitted.

**107.22 Hazardous and/or Toxic Waste**

When the Contractor's operations encounter or expose any abnormal condition which may indicate the presence of a hazardous and/or toxic waste, such operations shall be discontinued in the vicinity of the abnormal condition and the Engineer shall be notified immediately. The presence of barrels, discolored earth, metal, wood, or visible fumes, abnormal odors, excessively hot earth, smoke, or anything else which appears abnormal may be indicators of hazardous and/or toxic wastes and shall be treated with extraordinary caution as they are evidence of abnormal conditions.

The Contractor's operations shall not resume until so directed by the Engineer.

Disposition of the hazardous and/or toxic waste will be made in accordance with the requirements and regulations of the Department of Human Resources and the Department of Natural Resources. Where the Contractor performs work necessary to dispose of hazardous and/or toxic waste, payment will be made at the unit prices for pay items included in the contract which are applicable to such work or, where the contract does not include such pay items, payment will be as provided in Subsection 109.05, "Extra Work."

**107.23 Environmental Considerations**

**A. Construction**

Erosion control measures shall be installed, to the greatest practical extent, prior to clearing and grubbing. Particular care shall be exercised along stream buffers, wetlands, open waters and other sensitive areas to ensure that these areas are not adversely affected.

Construction equipment shall not cross streams, rivers, or other waterways except at temporary stream crossing structures shown on the plans or as allowed by permit.

Construction activities within wetland areas are prohibited except for those within the construction limits as shown on the Plans and as specified in Subsection 107.23.E.

**EXHIBIT O**  
**CDBG FEDERAL/LOCAL PROJECT REQUIREMENTS**

All sediment control devices (except sediment basins) installed on a project shall, as a minimum, be cleaned of sediment when one half the capacity, by height, depth or volume, has been reached. Sediment basins shall be cleaned of sediment when one-third the capacity by volume has been reached.

**B. Bridge Construction Over Waterways**

Construction waste or debris, from bridge construction or demolition, shall be prevented from being allowed to fall or be placed into wetlands, streams, rivers or lakes.

Excavation, dewatering, and cleaning of cofferdams shall be performed in such a manner as to prevent siltation. Pumping from cofferdams to a settling basin or a containment unit will be required if deemed necessary by the Engineer.

Operations required within rivers or streams, i.e. jetting or spudding, shall be performed within silt containment areas, cofferdams, silt fence, sediment barriers or other devices to minimize migration of silt off the project.

**C. Environmental Clearance of Local Material or Disposal Sites**

Specific written environmental approval from the Engineer will be required for any local material or disposal sites not included in the Plans. No work shall be started at any potential local material or waste site not shown on the plans prior to receiving said environmental approval from the Engineer. Local material sites are defined as borrow pits, common borrow, base, embankment, sand clay base, topsoil base, soil cement base, granular embankment, asphalt sand, maintenance pits, or stockpiled borrow sources. Disposal sites, as defined in Standard Specification 201.3.05.E.3, may be defined as excess material, common fill, or inert waste.

The Contractor may obtain environmental approval on a site with one of two methods: 1) GDOT provided environmental surveys or 2) environmental surveys obtained by the Contractor at no cost to the Department. The Contractor must choose one method for review and approvals, which will apply to all sites required for a given project and submit an Environmental Review Notification indicating their chosen method.

1. If the Contractor chooses to obtain their own environmental surveys, they shall be conducted by a consultant(s) pre-bid-qualified to work with the Department in the following area classes: 1.06(b) – History; 1.06(e) – Ecology; and 1.06(f) – Archaeology. Background research and field methods shall be conducted in accordance with the Office of Environmental Services Environmental Procedures Manual, with documentation in an Environmental Survey Results Memorandum (template available from the Office of Environmental Services).
2. If the Contractor requests that GDOT conduct required environmental surveys, an Environmental Survey Request shall be submitted for each site (template available from the Office of Environmental Services).

Upon receipt of an Environmental Survey Request, the Office of Environmental Services shall provide environmental approval or denial within thirty (30) business days. Upon receipt of an Environmental Survey Results Memorandum, the Office of Environmental Services shall provide environmental approval or denial within ten (10) business days. The Department will not accept requests for review of sites before a Notice to Proceed is issued. Incomplete Survey Requests, surveys that are not conducted by a GDOT P.R.-qualified consultant, or surveys that do not meet the required level of field effort or documentation, will be denied by GDOT OES and may require re submittal.

The Engineer will inform the Contractor in writing as to the approval or denial of environmental clearance. Approvals may be provided upon condition that an Environmentally Sensitive Area (ESA) be designated within or adjacent to the site prior to use. All ESA stipulations shall be adhered to in accordance with Standard Specification 107.23.F. If a site is denied, the Contractor may, at no expense to the Department, seek to obtain permits or pursue other remedies that might otherwise render the site(s) acceptable, if available. All changes to proposed sites or their associated haul roads that are not included within the original Environmental Survey Request or Environmental Survey Results Memorandum, including expansion,

**EXHIBIT O**  
**CDBG FEDERAL/LOCAL PROJECT REQUIREMENTS**

utilization for purposes other than those indicated in the original submittal, etc. must be submitted for further environmental review and approval prior to use.

Sites included in the Plans have environmental clearance and shall be used only for the purpose(s) specified in the Plans or other contract documents. Should the Contractor wish to expand or utilize said sites for any purpose other than that provided for in the Plans or other contract documents, specific written environmental clearance as noted above shall be obtained.

**D. Control of Pollutants**

Pollutants or potentially hazardous materials, such as fuels, lubricants, lead paint, chemicals, or batteries, shall be transported, stored, and used in a manner to prevent leakage or spillage into the environment. The Contractor shall also be responsible for proper and legal disposal of all such materials.

Equipment, especially concrete or asphalt trucks, shall not be washed or cleaned-out on the Project except in areas where unused product contaminants can be prevented from entering waterways.

**E. Temporary Work in Wetlands Outside of the Construction Limits within the Right-of-Way and Easement Areas**

Temporary work in wetlands (that are not delineated with orange barrier fence) will be subject to the following requirements:

1. Temporary work in wetlands shall be accomplished by using temporary structures, timber, concrete, soil with geotextile fabric, or other suitable matting. The area shall not be grubbed.
2. Soil matting shall be protected from erosion in accordance with the Specifications.
3. Whenever temporary work is required in Saltwater Marsh Wetlands, all temporary structures and/or matting shall be removed in their entirety prior to Final Acceptance of the Project. Matted and compressed soil shall be backfilled to their original ground elevation with material meeting the requirements of Section 212 – Granular Embankment.
4. Whenever temporary work is required in Freshwater Wetlands, all temporary structures and/or matting (exclusive of soil matting to be retained in the final roadway section) shall be removed in their entirety prior to Final Acceptance of the Project.  
Once the temporary materials have been removed, the area shall be covered by Excelsior or Straw blankets according to Section 713 of the Specifications. The grassing and ground preparation referenced in Subsection 713.3.03, “Preparation”, will not be applicable to this Work.
5. The Engineer shall be notified so that a field inspection may be conducted to certify that the temporary materials were properly removed, and that the area was properly restored. The Contractor shall be responsible for any corrective action required to complete this Work.
6. There will be no separate measurement or payment for this Work. The cost associated with this work shall be included in the overall Bid submitted.

**F. Environmentally Sensitive Areas**

Some archaeological sites, historic sites, wetlands, streams, stream and pond buffers, open waters and protected animal and plant species habitat within the existing/required Right-of-Way and easement areas may be designated as ENVIRONMENTALLY SENSITIVE AREAS (ESA). These areas are shown on the applicable Plan sheets and labeled “ESA” (e.g., ESA – Historical Boundary, ESA – Wetland Boundary). The Department may require that some ESA's or portions thereof be delineated with orange barrier fence. The Contractor shall install, maintain, and replace as necessary orange barrier fence at ESA's as delineated in the Plan sheets.

The Contractor shall not enter, disturb, or perform any construction related activities, other than those shown on the approved plan sheets within areas designated as ESA's including ESA's or portions thereof not delineated with orange barrier fence. This includes but is not limited to the following construction activities: clearing and grubbing; borrowing; wasting; grading; filling; staging/stockpiling; vehicular use and parking,

**EXHIBIT O**  
**CDBG FEDERAL/LOCAL PROJECT REQUIREMENTS**

sediment basin placement; trailer placement; and equipment cleaning and storage. Also, all archaeological sites, historic sites, wetlands, streams, stream and pond buffers, open waters, and protected animal and plant species habitat that extend beyond the limits of existing/required Right-of- Way and easement areas shall be considered ESAs and the Contractor shall not perform any construction related activities (such as those listed above) within these areas or make agreements with property owners to occupy these areas for construction related activities (such as those listed above). The Contractor shall make all construction employees aware of the location(s) of each ESA and the requirement to not enter or otherwise disturb these areas.

If the Contractor is found to have entered an ESA, either within or outside the project area, for any purpose not specifically shown on the approved plan sheets, the Department may, at its discretion, issue a stop work order for all activities on the project except erosion control and traffic control until such time as all equipment and other items are removed and the ESA is restored to its original condition.

However, should damage to an ESA occur as a result of the Contractor's action in violation of this section, and notwithstanding any subsequent correction by the Contractor, the Contractor shall be liable for any cost arising from such action, including but not limited to, the cost of repair, remediation of any fines, or mitigation fees assessed against the Department by another government entity.

**G. Protection of Migratory Birds and Bats**

The following conditions are intended as a minimum to protect migratory birds and bats during construction activities.

1. Project personnel shall be advised about the potential presence and appearance of federally protected migratory birds, including the barn swallow (*Hirundo rustica*), cliff swallow (*Petrochelidon pyrrhonota*), and eastern phoebe (*Sayornis phoebe*), and that there are civil and criminal penalties for harassing, harming, pursuing, hunting, shooting, wounding, killing, capturing, or collecting these species in violation of the Migratory Bird Treaty Act of 1918. The law protects adults, fledglings, nestlings, eggs, and active nests. All bats are protected under Georgia state law (Official Code of Georgia § 27-1-28), with some species protected under the federal Endangered Species Act of 1973. Pictures and habitat information shall be posted in a conspicuous location in the Project field office until such time that construction has been completed and time charges have stopped.
2. The demolition of existing bridge and culvert, the extension of existing culvert, and bridge maintenance activities on the underside of the bridge deck shall take place outside of the breeding and nesting season of phoebes, swallows and other migratory birds, which begins April 1 and extends through August 31, unless exclusionary barriers are put in place to prevent birds from nesting. For bridges, exclusionary barriers may be made of plastic, canvas or other materials proposed by the Contractor and approved by the State Environmental Administrator prior to installation. For box culverts, exclusionary barriers may be overlapping strips of flexible plastic (also called "PVC Strip Doors" or "Strip Curtains") or an alternate material proposed by the Contractor and approved by the State Environmental Administrator prior to installation. Exclusionary barriers must be installed on the bridge(s) and/or box culvert(s) prior to March 1 or after August 31, but in no time in between this period. Exclusionary barriers are not a guaranteed method of preventing migratory birds from nesting beneath bridges and work schedules shall consider the possibility that barriers will not be successful. If exclusionary barriers are to be used, these steps shall be followed:
  - a. The Project ecologist shall be notified by phone (404) 631-1100 of the decision to install exclusionary barriers and the date of the proposed installation prior to the installation of any exclusionary devices.
  - b. The structure(s) shall be checked for nests prior to the placement of exclusionary barriers. If nests are present, they shall be inspected to ensure that eggs or birds are not present. If the nests are found to be occupied, construction activities associated with the bridge shall be postponed until after August 31 when the breeding season is complete.

**EXHIBIT O**  
**CDBG FEDERAL/LOCAL PROJECT REQUIREMENTS**

- c. For any box culvert(s) being replaced, exclusionary barriers shall be installed on both the inlet and outlet openings. For any box culvert(s) being extended, exclusionary barriers shall be placed on the opening(s) (inlet and/or outlet) where work is taking place. For bridge(s) being removed, barriers shall be installed along the full length of the bridge(s). In all cases, barriers shall be installed prior to March 1 and left in place until August 31 or until the culvert removal, culvert extension, or bridge demolition is complete. If the exclusionary barriers fail to prevent nesting (i.e., birds are able to bypass barriers and build nests), construction activities associated with the bridge shall be postponed until after August 31.
  - d. During construction activities, exclusionary barriers shall be inspected daily for holes or other defects that impair its ability to exclude migratory birds from nesting beneath the bridge. Any holes or defects shall be repaired immediately.
  - e. Entanglement and/or entrapment of barn swallows, cliff swallows, and eastern phoebes in exclusionary netting constitutes harm to migratory birds. Any entanglement and/or entrapment of migratory birds shall be reported immediately to the Project Engineer, who in turn will notify the State Environmental Administrator, Georgia Department of Transportation, Office of Environmental Services at (404) 631-1101.
3. Migratory birds may nest in other structures or natural features that will be impacted by construction activities. If active nests containing eggs are encountered within the footprint of construction activities, the finding shall be reported immediately to the Project Engineer, who in turn shall notify the State Environmental Administrator, Georgia Department of Transportation, Office of Environmental Services at (404) 631-1101. All activity within 50 feet of active nests shall cease pending consultation by the Department with the U. S. Fish and Wildlife Service and the lead Federal Agency.
  4. When working on bridges and culverts, sightings of bat species shall be reported immediately to the Project Engineer who in turn will notify the State Environmental Administrator, Georgia Department of Transportation, Office of Environmental Services at (404) 631-1101. All construction activity on the structure shall cease pending consultation by the Department with the U. S. Fish and Wildlife Service and/or the Georgia Department of Natural Resources and/or the lead Federal Agency. The Department will inform the Contractor of any changes to the project.
  5. In the event any incident occurs that causes harm or injury to migratory birds during construction activities, the incident shall be reported immediately to the Project Engineer who in turn shall notify the State Environmental Administrator, Georgia Department of Transportation, Office of Environmental Services at (404) 631-1101. All activity shall cease pending consultation by the Department with the U. S. Fish and Wildlife Service and the lead Federal Agency.
  6. Within 30 days of the completion of construction and the stopping of time charges, a report shall be provided to the State Environmental Administrator, Georgia Department of Transportation, Office of Environmental Services, 600 West Peachtree Street NW, Atlanta, Georgia 30308. GDOT in turn will provide copies of the report to the U.S. Fish and Wildlife Service, the Georgia Department of Natural Resources Wildlife Resources Division, and the lead Federal Agency. The following information will be included in the report:
    - a. Contractor name and address.
    - b. Name and title of report preparer.
    - c. GDOT Project Identification (PI) number.
    - d. County(s) in which project is located.
    - e. Project description.

**EXHIBIT O**  
**CDBG FEDERAL/LOCAL PROJECT REQUIREMENTS**

- f. Construction start and end dates.
  - g. Date GDOT was notified of intent to install barrier(s) per # 107.23G.2.a.
  - h. Number and type(s) of structures on which exclusion barriers were installed.
  - i. Type(s) of exclusion material used on each structure.
  - j. Start and end date(s) of installation of exclusionary barrier on each structure.
  - k. Start and end date(s) of removal of exclusionary barrier from each structure.
  - l. Photographs of each structure before and after exclusionary barrier installation.
  - m. Statement regarding whether the exclusionary barrier was effective in deterring bird use of the structure during construction.
  - n. Description of any incidents causing harm or injury to migratory birds during construction. This should include incidents that were reported as required under 107.23G.5.
  - o. Description of any sightings of bat species when working on bridges and culverts. This should include incidents that were reported as required under 107.23G.4.
7. All costs pertaining to any requirement contained herein shall be included in the overall bid submitted unless such requirement is designated as a separate Pay Item in the Proposal.

### **107.24 Closing of Roadways without On-Site Detours**

When existing roadways are to be closed to through traffic and on-site detours are not provided, the Contractor shall submit a written notice to the Engineer for approval 14 days prior to the closure of the existing roadways.

After receiving approval from the Engineer for the closure, the Contractor shall install signs at each closure site, in accordance with the MUTCD, to inform the traveling public of the proposed closure, including the date of closure. The sign shall be placed 5 days prior to the closure, at the direction of the Engineer.

Prior to the closure, the Area Engineer will inform local government officials and agencies, local news media, and the DOT Public Information Office of the proposed closure of the roadways.

### **107.25 Disruption to Residential and Commercial Property**

The Contractor shall plan, coordinate, and prosecute the work such that disruption to personal property and business is held to a practical minimum.

All construction areas abutting lawns and yards of residential or commercial property shall be restored promptly. Backfilling of each drainage structure or section of curb and gutter, sidewalk, or driveway shall be accomplished as soon as adequate strength is obtained. Finishing, dressing, and grassing shall be accomplished immediately thereafter as a continuous operation within each area being constructed with emphasis placed on completing each individual yard or business frontage. Care shall be taken to provide positive drainage to avoid ponding or concentration of runoff.

Handwork, including raking and smoothing, shall be required to ensure that roots, sticks, rocks, and other debris are removed to provide a neat and pleasing appearance. Grassing, when in season, shall immediately follow in order to establish permanent cover at the earliest date. If grassing is not in season, proper erosion control shall be installed and maintained.

The work described herein shall be in addition to that required by Subsection 104.07 "Final Cleaning Up" and Subsection 105.16 "Final Inspection and Acceptance."

**EXHIBIT O**  
**CDBG FEDERAL/LOCAL PROJECT REQUIREMENTS**

1<sup>st</sup> Use: July 2016  
Revised March 7, 2016

**DEPARTMENT OF TRANSPORTATION**  
**STATE OF GEORGIA**  
**SUPPLEMENTAL SPECIFICATION**

**Section 109—Measurement and Payment**

---

*Delete Subsection 109 and Substitute the following:*

**109.01 Measurement and Quantities**

The method of measurement and computations to be used in determination of quantities of material furnished and of work performed under the Contract will be those methods generally recognized as conforming to good engineering practice.

Unless otherwise specified, longitudinal measurements for area computations will be made along the surface, and no deductions will be made for individual fixtures having an area of 9 ft<sup>2</sup> (1 m<sup>2</sup>) or less. Unless otherwise specified, transverse measurements for area computations will be the neat dimensions shown on the Plans or ordered in writing by the Engineer.

Where payment is to be made by the square yard (square meter) for a specified thickness, the length will be measured on the surface along the centerline and the pay width shall be that width specified on the plans for the Final surface of the completed section. Intermediate courses shall be placed at a width sufficient to support successive courses with no detriment to the stability of the successive courses. The width of material required beyond the pay width will not be eligible for payment and shall be considered incidental to the work.

Structures will be measured according to neat lines shown on the Plans or as altered to fit field conditions.

All items which are measured by the linear foot (linear meter), such as pipe culverts, guard rail, underdrains, etc., will be measured parallel to the base or foundation upon which such structures are placed, unless otherwise shown on the Plans.

In computing volumes of excavation, the average end area method or other acceptable methods will be used.

The term “gage,” when used in connection with the measurement of steel plates, will mean the U.S. Standard Gage.

When the term “gage” refers to the measurement of electrical wire it will mean the wire gage specified in the National Electrical Code.

The term “ton” will mean the short ton consisting of 2,000 pounds avoirdupois. The term “megagram” will mean one metric ton, equivalent to 1,000 kg. Any commodity paid for by weight shall be weighed on scales that have been approved as specified below and which are furnished at the expense of the Contractor or Supplier. Weighing and measuring systems including remote controls shall be subject to type-approval by the Department of Transportation. The manufacture, installation, performance, and operation of such devices located in Georgia shall conform to, and be governed by, the Official Code of Georgia, Annotated, Section 10-2-5 of the Georgia Weights and Measures Act, the Georgia Weights and Measures Regulations, as amended and adopted, the current edition of the National Bureau of Standards Handbook 44, and these Specifications. Weighing and measuring systems located outside Georgia which are utilized for weighing materials to be used in Department work shall be manufactured, installed, approved, and operated in accordance with applicable laws and regulations for the state in which the scales are located.

All weighing, measuring, and metering devices used to measure quantities for payment shall be suitable for the purpose intended and will be “commercial devices.” Commodity scales located in Georgia shall be certified before use for accuracy, condition, etc., by the Weights and Measures Division of the Georgia Department of Agriculture, or its authorized representative. Scales located outside Georgia shall be certified in accordance with applicable laws and regulations for the state in which the scales are located. This certification shall have been made within a period of not more than one year prior to date of use for weighing commodity.

All equipment and all mechanisms and devices attached thereto or used in connection therewith shall be constructed, assembled, and installed for use so that they do not facilitate the perpetration of fraud. Any scale component or mechanism, which if manipulated would alter true scale values (including manual zero setting mechanisms) shall not be accessible to the

## EXHIBIT O CDBG FEDERAL/LOCAL PROJECT REQUIREMENTS

scale operator. Such components and mechanisms that would otherwise be accessible to the scale operator shall be enclosed. Provisions shall be made for security seals where appropriate on equipment and accessories. A security seal shall be affixed to any adjustment mechanism designed to be sealed. Scale or accessory devices shall not be used if security seals have been broken or removed.

Any certified scale or scale component which has been repaired, dismantled, or moved to another location shall again be tested and certified before it is eligible for weighing.

Whenever materials that are paid for based on weight are from a source within the State, the scales shall be operated by and the weights attested to by signature and seal of a duly authorized Certified Public Weigher in accordance with Standard Operating Procedure 15 and the Official Code of Georgia, Annotated, Section 10-2-5 of the Georgia Weights and Measures Act as amended and adopted. When such materials originate from another state that has a certified or licensed weigher program, the scales shall be operated by a weigher who is certified by that state in accordance with applicable laws, and weight ticket recordation shall be in accordance with Standard Operating Procedure 15.

When materials are paid for based on weight and originate from another state which has no program for certifying or licensing weighers, the materials shall be weighed on scales located in the State of Georgia by a Certified Public Weigher in accordance with Standard Operating Procedure 15 and the Official Code of Georgia, Annotated, Section 10-2-5 of the Georgia Weights and Measures Act as amended and adopted.

No scale shall be used to measure weights greater than the scale manufacturer's rated capacity. A digital recorder shall be installed as part of any commodity scale. The recorder shall produce a printed digital record on a ticket with the gross, tare, and net weights of the delivery trucks, along with the date and time printed for each ticket. Provisions shall be made so that the scales or recorders may not be manually manipulated during the printing process. The system shall be so interlocked as to allow printing only when the scale has come to rest. Either the gross or net weight shall be a direct scale reading. Printing and recording systems that can accept keyboard entries shall clearly and automatically differentiate a direct scale weight value from any other weight values printed on the load ticket.

All scales used to determine pay quantities shall be provided to attain a zero-balance indication with no load on the load receiving element by the use of semi-automatic zero (push-button zero) or automatic zero maintenance.

Vehicle scales shall have a platform of sufficient size to accommodate the entire length of any vehicle weighed and shall have sufficient capacity to weigh the largest load. Adequate drainage shall be provided to prevent saturation of the ground under the scale foundation.

The Engineer, at his discretion, may require the platform scales to be checked for accuracy. For this purpose, the Contractor shall load a truck with material of his choosing, weigh the loaded truck on his scales, and then weigh it on another set of certified vehicle scales. When the difference exceeds 0.4 percent of load, the scales shall be corrected and certified by a registered scale serviceman registered in the appropriate class as outlined in the Georgia Weights and Measures Regulations or in accordance with applicable requirements of the state in which the scales are located. A test report shall be submitted to the appropriate representative of the Department of Agriculture.

Materials to be measured by volume in the hauling vehicle shall be hauled in approved vehicles and measured therein at the point of delivery. Vehicles for this purpose may be of any size or type acceptable to the Engineer, provided that the body is of such shape that the actual contents may be readily and accurately determined. All vehicles shall be loaded to their water level capacity as determined by the Engineer, provided that the body is of such shape that the actual contents may be readily and accurately determined.

Cement and lime will be measured by the ton (megagram). Whenever cement or lime is delivered to the Project in tank trucks, a certified weight shall be made at the shipping point by an authorized Certified Public Weigher who is not an employee of the Department. Whenever cement and lime are from a source within the State, the scales shall be operated by the weights attested to by signature and seal of a duly authorized Certified Public Weigher in accordance with Standard Operating Procedure 15 and the Official Code of Georgia, Annotated, Section 10-2-5 of the Georgia Weights and Measures Act as amended and adopted. When such materials originate from another state that has a certified or licensed weigher program, the scales shall be operated by a weigher who is certified by that state in accordance with applicable laws, and the weight ticket recordation shall be in accordance with Standard Operating Procedure 15. When cement and lime originate from another state that has no program for certifying or licensing weighers, the materials shall be weighed on scales located in the State of Georgia by a Certified Public Weigher in accordance with Standard Operating Procedure 15 and the Official Code of Georgia, Annotated, Section 10-2-5 of the Georgia Weights and Measures Act as amended and adopted.

The shipping invoice shall contain the certified weights and the signature and seal of the Certified Public Weigher. A security seal shall also be affixed to the discharge pipe cap on the tank truck before leaving the shipping point. The number on the security seal shall also be recorded on the shipping invoice. The shipping invoice for quicklime shall also contain a certified lime purity percentage. Unsealed tank trucks will require reweighing by a Certified Public Weigher.



**EXHIBIT O**  
**CDBG FEDERAL/LOCAL PROJECT REQUIREMENTS**

Timber will be measured by the thousand feet board measure (MFBM) (cubic meter) incorporated in the structure. Measurements will be based on nominal widths and thickness and the actual length in place. No additional measurement will be made for splices except as noted for overlaps as shown on the Plans.

The term “Lump Sum” when used as an item of payment will mean complete payment for The Work described in the Contract.

When a complete structure or structural unit (in effect, “Lump Sum” work) is specified as the unit of the measurement, the unit will be construed to include all necessary fittings and accessories.

Rental of equipment will be measured as defined in Subsection 109.05.B.4.

When standard manufactured items are specified as fence, wire, plates, rolled shapes, pipe conduits, etc., and these items are identified by gage, unit weight, section dimensions, etc., such identification will be nominal weights or dimensions. Unless more stringently controlled by tolerance in cited Specifications, manufacturing tolerances established by the industries involved will be accepted.

## **109.02 Measurement of Bituminous Materials**

### **A. By Weighing the Material**

The Department prefers this method whenever it is practicable. This method will be considered acceptable under the following conditions:

1. **Weighted On Project:** If the weights of the bituminous materials delivered by tank trucks are to be determined on the Project, weights shall be determined on scales that have been previously checked by the Department with standard weights for accuracy. The scale platform shall be large enough to accommodate the entire vehicle at one time. Under no conditions will truck scales be used to measure weights greater than their rated capacity. All weights not determined in the presence of an authorized representative of the Department shall be made by a Certified Public Weigher who is not an employee of the Department of Transportation and who is in good standing with the Georgia Department of Agriculture. The weight tickets shall carry both the signature and seal of the Certified Public Weigher.
2. **Weighted At Shipping Point:** A certified weight made at the shipping point by an authorized Certified Public Weigher who is not an employee of the Department of Transportation and who is registered with the Georgia Department of Agriculture, will be acceptable provided all openings in the tank have been sealed by the producer and when, upon inspection on the Project, there is no evidence of any leakage. The shipping ticket in this case must carry the signature and seal of the Certified Public Weigher. If the tank is not completely emptied the amount of material remaining in the tank truck will be measured by either weight or volume and the amount so determined, as verified by the Engineer, will be deducted from the certified weight.
3. **By Extraction Analysis:** The weight of bituminous material used will be determined by extraction tests made by the field laboratory. The average asphalt content for each Lot will be used to compute the weight of the Asphalt Cement to be paid for in accordance with the following formula:

English:

$$P = \% AC \times T$$

Where:

P = Pay Tons of Asphalt Cement

% AC = Lot average of % Asphalt Cement by weight of total mix as determined by extraction

T = Actual accepted tons of mixture as weighed

Metric:

$$P = \% AC \times T$$

Where:

P = Pay megagrams of Asphalt Cement

% AC = Lot average of % Asphalt Cement by weight of total mix as determined by extraction

T = Actual accepted megagrams of mixture as weighed

4. **By Digital Recording Device:** The amount of bituminous material as shown on the printed tickets will be the Pay Quantity.

**EXHIBIT O**  
**CDBG FEDERAL/LOCAL PROJECT REQUIREMENTS**

**B. By Volume**

The volume will be measured and corrected for the difference between actual temperature and 60 °F (15 °C). Containers shall be level when measured, and one of the following methods shall be used, whichever is best suited to the circumstances:

1. **Tank Car Measurement:** If the material is shipped to the Project in railroad tank cars, the Contractor shall furnish the Engineer a certified chart showing the dimensions and volume for each inch (25 mm) of depth for each tank. The Engineer will make outage and temperature measurements before unloading is begun and after it is finished. The measurements will be taken when the bituminous material is at a uniform temperature and free from air bubbles. The Contractor shall not remove any bituminous material from any tank until necessary measurements have been made nor shall he release the car until final outage has been measured. The total number of gallons (liters) allowed for any tank car shall not be more than the U.S. Interstate Commerce Commission rating for that car, converted to gallons at 60 °F (15 °C).
2. **Truck Measurement:** If bituminous materials are delivered to the Project in tank trucks, distributor tanks, or drums, the Contractor shall not remove any bituminous material from the transporting vehicle or container until necessary measurements have been made, nor shall the transporting vehicle or container be released until final outage has been measured. If weighing is not convenient, the Contractor shall furnish the Engineer with a certified chart showing the dimensions and volume of each container together with a gauge or calibrated measuring rod which will permit the volume of the material to be determined by vertical measurement.
3. **Metering:** The volume may be determined by metering, in which case the metering device used and the method of using it shall be subject to the approval of the Engineer.
4. **Time of Deliveries:** The arrival and departure of vehicles delivering bituminous materials to the Project site shall be so scheduled that the Engineer is afforded proper time for the measurements of delivered volume and final outage. The Engineer will make the necessary measurements only during the Contractor's normal daily working hours.

**C. Production for Multiple Projects**

When a Contractor is producing Asphaltic Concrete from one plant, which is being placed on two or more jobs, public or private, the amount of bituminous material used may be determined by extraction tests in accordance with Subsection 109.02.A.3 or digital recording device in accordance with Subsection 109.02.A.4.

**D. Tack Coat**

When the same storage facility is utilized for Bituminous Materials to be used in Hot Mix Asphaltic Concrete, Bituminous Tack Coat, and/or Surface Treatment, the quantity used for Tack Coat shall be converted to tons (megagrams) and deducted from the quantities for the Bituminous Material used in the Hot Mix Asphaltic Concrete and Surface Treatment.

**E. Corrections**

When the volume and temperature have been determined as defined above, the volume will be corrected by the use of the following formula:

$$V_{\text{English}} = \frac{V1}{K(t-60) + 1} \qquad V_{\text{metric}} = \frac{V1}{K(t-15) + 1}$$

Where:

V = Volume of bituminous material at 60 °F (15 °C)

V1= Volume of hot bituminous material

t = Temperature of hot bituminous material in degrees Fahrenheit (Celsius)

K= Coefficient of Expansion of bituminous material (correction factor)

The correction factors K for various materials are given below:

- 0.00035 (0.00063) per °F (°C) for petroleum oils having a specific gravity of 60 °F/60 °F (15 °C/15 °C) above 0.966
- 0.00040 (0.00072) per °F (°C) for petroleum oils having a specific gravity of 60 °F/60 °F (15 °C/15 °C) between 0.850-0.966
- 0.00030 (0.00054) per °F (°C) for Tar
- 0.00025 (0.00045) per °F (°C) for Emulsified Asphalt
- 0.00040 (0.00072) per °F (°C) for Creosote Oil

**EXHIBIT O**  
**CDBG FEDERAL/LOCAL PROJECT REQUIREMENTS**

**109.03 Scope of Payment**

The Contractor shall receive and accept the compensation provided for in the Contract as full payment for furnishing all materials, labor, tools, equipment, superintendence and incidentals, and for performing all work contemplated and embraced under the Contract in a complete and acceptable manner, for any infringement of patent, trademark or copyright, for all loss or damage arising from the nature of The Work, or from the action of the elements, for all expenses incurred by or in consequence of the suspension or discontinuance of The Work, or from any unforeseen difficulties which may be encountered during the prosecution of The Work and for all risks of every description connected with the prosecution of The Work until its Final Acceptance by the Engineer, except as provided in Subsection 107.16.

The payment of any partial estimate prior to Final Acceptance of the Project as provided in Subsection 105.16 shall in no way affect the obligation of the Contractor to repair or renew any defective parts of the construction or to be responsible for all damages due to such defects.

**109.04 Payment and Compensation for Altered Quantities**

When alteration in Plans or quantities of work not requiring Supplemental Agreements as herein before provided for are ordered and performed, the Contractor shall accept payment in full at the Contract Unit Bid Prices for the actual quantities of work done, and no allowance will be made for increased expense, loss of expected reimbursement, or loss of anticipated profits suffered or claimed by the Contractor, resulting either directly from such alterations, or indirectly from unbalanced allocation among the Contract Items of overhead expense on the part of the Bidder and subsequent loss of expected reimbursement therefore, or from any other cause.

Compensation for alterations in Plans or quantities of work requiring Supplemental Agreements shall be as stipulated in such agreement, except that when the Contractor proceeds with The Work without change of price being agreed upon, he shall be paid for such increased or decreased quantities at the Contract Unit Prices Bid in the Proposal for the Items of The Work.

**109.05 Extra Work**

Extra work, as defined in Subsection 101.27, when ordered in accordance with Subsection 104.04, will be authorized in writing by the Engineer. The authorization will be in the form of a Supplemental Agreement or a Force Account.

**A. Supplemental Agreement**

In the case of a Supplemental Agreement, the work to be done will be stipulated and agreed upon by both parties prior to any extra work being performed.

Payment based on Supplemental Agreements shall constitute full payment and settlement of all additional costs and expenses including delay and impact damage caused by, arising from, or associated with The Work performed.

**B. Force Account**

When no agreement is reached for Extra Work to be done at Lump Sum or Unit Prices, such work may be authorized by the Department to be done on a Force Account basis. A Force Account estimate that identifies all anticipated costs shall be prepared by the Contractor on forms provided by the Engineer. Work shall not begin until the Force Account is approved. Payment for Force Account work will be in accordance with the following:

1. **Labor:** For all labor, equipment operators and supervisors, excluding superintendents, in direct charge of the specific operations, the Contractor shall receive the rate of wage agreed upon in writing before beginning work for each hour that said labor, equipment operators and supervisors are actually engaged in such work. The Contractor shall receive the actual costs paid to, or in behalf of, workers by reason of subsistence and travel allowances, health and welfare benefits, pension fund benefits, or other benefits, when such amounts are required by collective bargaining agreement or other employment contract generally applicable to the classes of labor employed on The Work.  
An amount equal to 15% of the sum of the above items will also be paid the Contractor.
2. **Bond, Insurance, and Tax:** For property damage, liability, and worker's compensation insurance premiums, unemployment insurance contributions, and Social Security taxes on the Force Account work, the Contractor shall receive the actual cost, to which cost no percentage will be added. The Contractor shall furnish satisfactory evidence of the rate or rates paid for such bond, insurance, and tax.
3. **Materials:** For materials accepted by the Engineer and used, the Contractor shall receive the actual cost of such material incorporated into The Work, including Contractor paid transportation charges (exclusive of machinery rentals as hereinafter set forth), to which cost 10% will be added.
4. **Equipment:** For any machinery or special equipment (other than small tools) including fuel and lubricant, plus transportation costs, the use of which has been authorized by the Engineer, the Contractor shall receive the rental

**EXHIBIT O**  
**CDBG FEDERAL/LOCAL PROJECT REQUIREMENTS**

rates indicated below for the actual time that such equipment is in operation on The Work or the time, as indicated below, the equipment is directed to stand by.

Equipment rates shall be based on the latest edition of the *Rental Rate Blue Book for Construction Equipment* or *Rental Rate Blue Book for Older Construction Equipment*, whichever applies, as published by Equipment Watch using all instructions and adjustments contained therein and as modified below.

Allowable Equipment Rates shall be established as defined below:

- Allowable Hourly Equipment Rate = Monthly Rate/176 x Adjustment Factors.
- Allowable Hourly Operating Cost = Hourly Operating Cost.
- Allowable Rate Per Hour = Allowable Hourly Equipment Rate + Allowable Hourly Operating Cost.
- Standby Rate = Allowable Hourly Equipment Rate x 35%

NOTE: The monthly rate is the basic machine plus any attachments.

Standby rates shall apply when equipment is not in operation and is directed by the Engineer to standby for later use. In general, Standby rates shall apply when equipment is not in use but will be needed again to complete The Work and the cost of moving the equipment will exceed the accumulated standby cost. Payment for standby time will not be made on any day the equipment operates for 8 or more hours. For equipment accumulating less than 8 hours operating time on any normal workday, standby payment will be limited to only that number of hours which, when added to the operating time for that day equals 8 hours. Standby payment will not be made on days that are not normally considered workdays.

The Department will not approve any rates more than the rates as outlined above unless such excess rates are supported by an acceptable breakdown of cost.

Payable time periods will not include:

- Time elapsed while equipment is broken down.
- Time spent in repairing equipment, or
- Time elapsed after the Engineer has advised the Contractor the equipment is no longer needed.

If a piece of equipment is needed which is not included in the above *Blue Book* rental rates, reasonable rates shall be agreed upon in writing before the equipment is used. All equipment charged by persons or firms other than the Contractor shall be supported by invoices.

Transportation charges for each piece of equipment to and from the site of The Work will be paid provided:

- The equipment is obtained from the nearest approved source.
- The return charges do not exceed the delivery charges.
- Haul rates do not exceed the established rates of licensed haulers, and
- Such charges are restricted to those units of equipment not already available and not on or near the Project.

No additional compensation will be made for equipment repair.

5. **Miscellaneous:** No additional allowance will be made for general superintendence, the use of small tools, or other costs for which no specific allowance is herein provided.
6. **Compensation:** The Contractor's representative and the Engineer shall compare records and agree on the cost of work done as ordered on a Force Account basis at the end of each day on forms provided by the Department.
7. **Subcontract Force Account Work:** For work performed by an approved Subcontractor or Second-tier Subcontractor, all provisions of this Section (109.05) that apply to the Prime Contractor in respect to labor, materials and equipment shall govern. The prime Contractor shall coordinate the work of his Subcontractor. The prime Contractor will be allowed an amount to cover administrative cost equal to 5% of the Subcontractor's amount earned but not to exceed \$5,000.00 per Subcontractor. Markup for Second-tier Subcontract work will not be allowed.

Should it become necessary for the Contractor or Subcontractor to hire a firm to perform a specialized type of work or service which the prime Contractor or Subcontractor is not qualified to perform, payment will be made at reasonable invoice cost. To each invoice cost a markup to cover administrative cost equal to 5% of the total invoice but not to exceed \$5,000.00 will be allowed the Contractor or Subcontractor but not both.

8. **Statements:** No payment will be made for work performed on a Force Account basis until the Contractor has furnished the Engineer with duplicate itemized statements of the cost of such Force Account work detailed as follows:

**EXHIBIT O**  
**CDBG FEDERAL/LOCAL PROJECT REQUIREMENTS**

- a. Name, classification, date, daily hours, total hours, rate, and extension for each laborer, equipment operator, and supervisor, excluding superintendents.
- b. Designation, dates, daily hours, total hours, rental rate, and extension for each unit of machinery and equipment.
- c. Quantities of materials, prices, and extensions.
- d. Transportation of materials.
- e. Cost of property damage, liability, and worker's compensation insurance premiums, unemployment insurance contributions, and Social Security tax.

Statements shall be accompanied and supported by invoices for all materials used and transportation charges. However, if materials used on the Force Account work are not purchased specifically for such work but are taken from the Contractor's stock, then, in lieu of the invoices, the Contractor shall furnish an affidavit certifying that such materials were taken from his stock, that the quantity claimed was actually used, and that the price and transportation claimed represent the actual cost to the Contractor.

Payment based on Force Account records shall constitute full payment and settlement of all additional costs and expenses including delay and impact damages caused by, arising from, or associated with The Work performed.

### **109.06 Eliminated Items**

Should any Items contained in the Proposal be found unnecessary for the proper completion of The Work, the Engineer may, upon written order to the Contractor, eliminate such Items from the Contract, and such action shall in no way invalidate the Contract. When a Contractor is notified of the elimination of Items, he will be reimbursed for actual work done and all costs incurred, including mobilization of materials prior to said notifications.

### **109.07 Partial Payments**

#### **A. General**

At the end of each calendar month, the total value of Items complete in place will be estimated by the Engineer and certified for payment. Such estimate is approximate only and may not necessarily be based on detailed measurements. Value will be computed based on Contract Item Unit Prices or on percentage of completion of Lump Sum Items. When so requested by the Contractor and approved by the Engineer, Gross Earnings of \$500,000.00 or more for work completed within the first 15 days of any month will be certified for payment on a semi-monthly basis subject to the conditions and provisions of Subsection 109.07.A, Subsection 109.07.B.6, Subsection 109.07.C, Subsection 109.07.D, Subsection 109.07.E, and Subsection 109.07.F.

#### **B. Materials Allowance**

Payments will be made on delivered costs, or percentage of bid price if otherwise noted, with copies of paid invoices provided to the Department for the materials listed below which are to be incorporated into the Project provided the materials:

- Conform to all Specification requirements.
- Are stored on the Project Right-of-Way or, upon written request by the Contractor and written approval of the Engineer, they may be stored off the Right-of-Way, but local to the Project, provided such storage is necessary due to lack of storage area on the Right-of-Way, need for security, or need for protection from weather.

As a further exception to on-Project storage, upon written request by the Contractor, the Engineer may approve off-the-Project storage items uniquely fabricated or precast for a specific Project, such as structural steel and precast concrete, which will be properly marked with the Project number and stored at the fabrication or precast facility.

The Engineer may approve out-of-state storage for structural steel and prestressed concrete beams uniquely fabricated for a specific Project stored at the fabrication facility.

1. Paid invoices should accompany the materials allowance request, but in no case be submitted to the Project Engineer later than 30 calendar days following the date of the progress payment report on which the materials allowance was paid.

In case such paid invoices are not furnished within the established time, the materials allowance payment will be removed from the next progress statement and no further materials allowance will be made for that item on that Project.

2. Materials allowances will be paid for those items which are not readily available, and which can be easily identified and secured for a specific project and for which lengthy stockpiling periods would not be detrimental. Some exclusions are as follows:

**EXHIBIT O**  
**CDBG FEDERAL/LOCAL PROJECT REQUIREMENTS**

- a. No payments will be made on living or perishable plant materials until planted.
  - b. No payments will be made on Portland Cement, Liquid Asphalt, or Grassing Materials.
  - c. No payment will be made for aggregate stockpiled in a quarry. Payment for stockpiled aggregate will be made only if the aggregate is stockpiled on or in the immediate vicinity of the project and is held for the exclusive use on that project. The aggregate must be properly secured. If the aggregate stockpiled is to be paid for per-ton (megagram) it must be reweighed on approved scales at the time it is incorporated into the Project.
  - d. No payments will be made on minor material items, hardware, etc.
3. No materials allowance will be made for materials when it is anticipated that those materials will be incorporated into The Work within 30 calendar days.
  4. No materials allowance will be made for a material when the requested allowance for such material is less than \$25,000.
  5. Where a storage area is used for more than one project, material for each project shall be segregated from material for other projects, identified, and secured. Adequate access for auditing shall be provided. All units shall be stored in a manner so that they are clearly visible for counting and/or inspection of the individual units.
  6. Materials allowance for prestressed concrete and structural steel bridge members may be processed for uncast or unfabricated members upon the Engineer's receipt of a true copy of the binding order for the members required by the plan. Such copy shall be sealed and notarized by both the contractor placing the order and the supplier therein identified to cast or fabricate said members. All orders shall demonstrate conformance to the approved plans and specifications regarding beam type, size, length, material quantities and shall not exceed the approved plan quantity. The materials allowance applied to uncast prestressed concrete members will be made in amount equal to 40% of the invoice for the respective member(s) to the contractor. The materials allowance applied to unfabricated structural steel bridge members will be made in amount equal to 55% of the invoice for the respective member(s) to the contractor. An additional material allowance may be requested separately upon completion of the casting or fabricating for a maximum 90% of the invoice for the member(s) provided there is adherence to all other provisions of this specification.
  7. The Commissioner may, at his discretion, grant waiver to the requirements of this Section when, in his opinion, such waiver would be in the public interest.

Subsequently, in the event the material is not on-hand and in the quantities for which the materials allowance was granted, the materials allowance payment will be removed from the next progress statement and no further materials allowance will be made for those items on that Project. If sufficient earnings are not available on the next progress statement, the Contractor agrees to allow the Department to recover the monies from any other Contract he may have with the Department, or to otherwise reimburse the Department.

Excluding item 6 above, payments for materials on hand shall not exceed the invoice price or 75 percent of the bid prices for the pay items into which the materials are to be incorporated, whichever is less.

**C. Minimum Payment**

No partial payment will be made unless the amount of payment is at least \$1000.00.

**D. Liquidated Damages**

Accrued liquidated damages will be deducted in accordance with Subsection 108.08.

**E. Other Deductions**

In addition to the deductions provided for above, the Department has the right to withhold any payments due the Contractor for items unpaid by the Contractor for which the Department is directly responsible, including, but not limited to, royalties (see Section 106).

**F. Amount of Payment**

The balance remaining, after all deductions provided for herein have been made will be paid to the Contractor. Partial estimates are approximate and are subject to correction on subsequent progress statements. If sufficient earnings are not available on the subsequent progress statement, the Contractor agrees to allow the Department to recover the monies from any other Contract he may have with the Department, or to otherwise reimburse the Department. The Engineer is responsible for computing the amounts of all deductions herein specified, for determining the progress of the Work and for the items and amounts due to the Contractor during the progress of the Work and for the final statement when all Work has been completed.

**EXHIBIT O**  
**CDBG FEDERAL/LOCAL PROJECT REQUIREMENTS**

**G. Interest**

Under no circumstances will any interest accrue or be payable on any sums withheld or deducted by the Department as authorized by Subsection 109.07.A, Subsection 109.07.B.6, Subsection 109.07.C, Subsection 109.07.D, Subsection 109.07.E, and Subsection 109.07.F.

**H. Insert the Following in Each Subcontract**

The Contractor shall insert the following in each Subcontract entered for work under this Contract:

“The Contractor shall not withhold any retainage on Subcontractors. The Contractor shall pay the Subcontractor 100% percent of the gross value of the Completed Work by the Subcontractor as indicated by the current estimate certified by the Engineer for payment.”

Neither the inclusion of this Specification in the Contract between the Department and the Prime Contractor nor the inclusion of the provisions of this Specification in any Contract between the Prime Contractor and any of his Subcontractors nor any other Specification or Provision in the Contract between the Department and the Prime Contractor shall create, or be deemed to create, any relationship, contractual or otherwise, between the Department and any Subcontractor.

**109.08 Final Payment**

When Final Inspection and Final Acceptance have been made by the Engineer as provided in Subsection 105.16, the Engineer will prepare the Final Statement of the quantities of the various classes of work performed. All prior partial estimates and payments shall be subject to correction in the Final Statement. The District Engineer will transmit a copy of the Statement to the Contractor by Registered or Certified Mail. The Contractor will be afforded 35 days in which to review the Final Statement in the District Office before it is certified for payment by the Engineer. Any adjustments will be resolved by the District Engineer or in case of a dispute referred to the Chief Engineer whose decision shall be final and conclusive. After approval of the Final Statement by the Contractor, or after the expiration of the 35 days, or after a final ruling on disputed items by the Chief Engineer, the Final Statement shall be certified to the Treasurer by the Chief Engineer stating the Project has been accepted and that the quantities and amounts of money shown thereon are correct, due and payable.

The Treasurer, upon receipt of the Engineer’s certification, shall in turn furnish the Contractor with the Department’s Standard Release Form to be executed in duplicate. The aforesaid Release Form, showing the total amount of money due the Contractor, shall be sent to the Contractor by Registered or Certified Mail, to be delivered to such Contractor upon the signing of a return receipt card, to be returned to the Department in accordance with the provision of Federal law in respect to such matters and such return receipt card shall be conclusive evidence of a tender of said sum of money to the Contractor. Upon receipt of the properly executed Standard Release Form, the Treasurer shall make final payment jointly to the Contractor and his Surety. The aforesaid certification, executed release form, and final payment shall be evidence that the Commissioner, the Engineer, and the Department have fulfilled the terms of the Contract, and that the Contractor has fulfilled the terms of the Contract except as set forth in his Contract Bond.

The Standard Release Form is to be carried out by the Contractor within 45 days after delivery thereof, as evidenced by the Registered or Certified Mail Return Receipt. Should the Contractor fail to execute the Standard Release Form because he disputes the Final Payment as offered, or because he believes he has a claim for damages or additional compensation under the Contract, the Contractor shall, within 45 days after delivery to the Contractor of the Standard Release Form, as evidenced by the Registered or Certified Mail Return Receipt, enter suit in the proper court for adjudication of his claim. Should the Contractor fail to enter suit within the aforesaid 45 days, then by agreement hereby stipulated, he is forever barred and stopped from any recovery or claim whatsoever under the terms of this Contract.

Should the Contractor fail to execute the Standard Release Form or file suit within 45 days after delivery thereof, then the Surety on the Contractor’s Bond is hereby constituted the attorney-in-fact of the Contractor for the purpose of executing such final releases as may be required by the Department, including but not limited to the Standard Release Form, and for the purpose of receiving the Final Payment under this Contract.

The Department reserves the right as defined in Subsection 107.20, should an error be discovered in any estimates, to claim and recover from the Contractor or his Surety, or both, such sums as may be sufficient to correct any error of overpayment. Such overpayment may be recovered from payments due on current active Projects or from any future State work done by the Contractor.

The foregoing provisions of this Section shall be applicable both to the Contractor and the Surety on his Bond; and, in this respect, the Surety shall be bound by the provisions of Subsection 108.09 of these Specifications in the same way and manner as the Contractor.

**EXHIBIT O**  
**CDBG FEDERAL/LOCAL PROJECT REQUIREMENTS**

**A. Interest**

In the event the Contractor fails to execute the *Standard Release Form* as prepared by the Treasurer because he disputes the amount of the final payment as stated therein, the amount due the Contractor shall be deemed by the Contractor and the Department to be an unliquidated sum and no interest shall accrue or be payable on the sum finally determined to be due to the Contractor for any period prior to final determination of such sum, whether such determination be by agreement of the Contractor and the Department or by final judgement of the proper court in the event of litigation between the Department and the Contractor. The Contractor specifically waives and renounces any and all rights it may have under Section 13-6-13 of the Official Code of Georgia and agrees that in the event suit is brought by the Contractor against the Department for any sum claimed by the Contractor under the Contract, for delay damages resulting from a breach of contract, for any breach of contract or for any extra or additional work, no interest shall be awarded on any sum found to be due from the Department to the Contractor in the final judgement entered in such suit. All final judgements shall draw interest at the legal rate, as specified by law. Also, the Contractor agrees that notwithstanding any provision or provisions of Chapter 11 of Title 13 of the Official Code of Georgia that the provisions of this contract control as to when and how the Contractor shall be paid for The Work. Further, the Contractor waives and renounces any rights it may have under Chapter 11 of Title 13 of the Official Code of Georgia.

**B. Termination of Department's Liability**

Final payment will be in the amount determined by the statement as due and unpaid. The acceptance of the final payment or execution of the Standard Release Form or failure of the Contractor to act within 120 days as provided herein after tender of payment, or final payment to the Contractor's Surety in accordance with the provisions stipulated herein, shall operate as and be a release to the Department, the Commissioner, and the Engineer from all claims of liability under this contract and for any act or neglect of the Department, the Commissioner, or the Engineer.

**109.09 Termination Clause****A. General**

The Department may, by written notice, terminate the Contract or a portion thereof for the Department's convenience when the Department determines that the termination is in the State's best interest, or when the Contractor is prevented from proceeding with the Contract as a direct result of one of the following conditions:

1. An Executive Order of the President of the United States with respect to the prosecution of war or in the interest of national defense.
2. The Engineer and Contractor each make a determination, that, due to a shortage of critical materials required to complete the Work which is caused by allocation of these materials to work of a higher priority by the Federal Government or any agency thereof, it will be impossible to obtain these materials within a practical time limit and that it would be in the public interest to discontinue construction.
3. An injunction is imposed by a court of competent jurisdiction which stops the Contractor from proceeding with the Work and causes a delay of such duration that it is in the public interest to terminate the Contract and the Contractor was not at fault in creating the condition which led to the court's injunction.  
The decision of the Engineer as to what is in the public interest and as to the Contractor's fault, for the purpose of Termination, shall be final.
4. Orders from duly constituted authority relating to energy conservation.

**B. Implementation**

When, under any of the conditions set out in Subsection A of this Section, the Contract, or any portion thereof, is terminated before completion of all Items of Work in the Contract, the Contractor shall be eligible to receive some or all the following items of payment:

1. For the actual number of units of Items of Work completed, payment will be made at the Contract Unit Price.
2. Reimbursement for organization of the Work and moving equipment to and from the job will be considered where the volume of work completed is too small to compensate the Contractor for these expenses under the Contract Unit Prices. However, the Engineer's decision as whether to reimburse for organization of the Work and moving equipment to and from the job, and in what amount, shall be final.
3. Acceptable materials, obtained by the Contractor for the Work, that have been inspected, tested, and accepted by the Engineer, and that are not incorporated in the Work will, at the request of the Contractor, be purchased from the Contractor at actual cost as shown by receipted bills and actual cost records at such points of delivery as may be designated by the Engineer. This will include any materials that have been delivered to the project site or that have been specifically fabricated for the project and are not readily usable on other projects. It will not include materials



**EXHIBIT O**  
**CDBG FEDERAL/LOCAL PROJECT REQUIREMENTS**

that may have been ordered, but not delivered to the project site and that are readily usable on other projects (e.g., guard rail, stone, lumber, etc.).

4. For Items of Work partially completed, payment adjustments including payments to afford the Contractor a reasonable profit on work performed, may be made as determined by the Engineer based upon a consideration of costs actually incurred by the Contractor in attempting to perform the Contract.
5. No payment will be made, and the Department will have no liability for lost profits on Work not performed. In particular, the Department will not be liable to the Contractor for all profits the Contractor expected to realize had the Project been completed, nor for any loss of business opportunities, nor for any other consequential damages.
6. In order that the Department may make a determination of what sums are payable hereunder, the Contractor agrees that, upon termination of the Contract, it will make all of its books and records available for inspection and auditing by the Department.

To be eligible for payment, costs must have been actually incurred, and must have been recorded and accounted for according to generally accepted accounting principles and must be items properly payable under Department policies. Where actual equipment costs cannot be established by the auditors, payment for un-reimbursed equipment costs will be made in the same manner as is provided in Subsection 109.05 for Force Account Work. Idle time for equipment shall be reimbursed at standby rates. In no case will the Contractor be reimbursed for idle equipment after the Engineer has advised the Contractor the equipment is no longer needed on the job. Refusal of the Contractor to allow the Department to inspect and audit all of the Contractor's books and records shall conclusively establish that the Department has no liability to the Contractor for any payment under this provision, and shall constitute a waiver by the Contractor of any claim for damages allegedly caused by breach or termination of the Contract. The amount payable under this provision if any, is to be determined by the Engineer, whose determination will be final and binding.

7. The sums payable under this Subsection shall be the Contractor's sole and exclusive remedy for termination of the Contract.

**C. Termination of a Contract**

Termination of a Contract or a portion thereof shall not relieve the Contractor of his responsibilities for any completed portion of the Work, nor shall it relieve his Surety of its obligation for and concerning any just claims arising out of the Work performed.

**109.10 Interest**

In the event any lawsuit is filed against the Department alleging the Contractor is due additional money because of claims or for any breach of contract, the Contractor hereby waives and renounces any right it may have under O.C.G.A. Section 13-6-13 to prejudgment interest. Also, the Contractor agrees that notwithstanding any provision or provisions of Chapter 11 of Title 13 of the Official Code of Georgia that the provisions of this contract control as to when and how the Contractor shall be paid for The Work. Further, the Contractor waives and renounces any rights it may have under Chapter 11 of Title 13 of the Official Code of Georgia.

**EXHIBIT O**  
**CDBG FEDERAL/LOCAL PROJECT REQUIREMENTS**

First Use Date: September 19, 2014

**DEPARTMENT OF TRANSPORTATION**  
**STATE OF GEORGIA**

**SPECIAL PROVISION**

**Section 109—Measurement and Payment**

---

*Add the following:*

**109.11 Price Adjustments**

- A. Asphalt Cement Price Adjustments will be computed *monthly* in accordance with the following:

PA = Price Adjustment.

APM= the “Monthly Asphalt Cement Price (Georgia Base Asphalt Price)” for the month the hot mix asphalt/bituminous tack/bituminous surface treatment is placed.

APL = the “Monthly Asphalt Cement Price (Georgia Base Asphalt Price)” for the month which the project was let.

TMT = Total Monthly Tonnage of asphalt cement computed by the Engineer based on the Hot Mix Asphaltic Concrete of the various types per ton (megagram)//Total Monthly Tonnage of asphalt cement used for bituminous tack coat (asphalt cement tack coat only, emulsified bituminous materials for tack coat are excluded) converted from gallons to tons (megagrams) by the Engineer//Total Monthly Tonnage of asphalt cement used for bituminous surface treatment (total gallons of asphalt emulsion used, as measured from distributors, will be multiplied by a factor of 0.65 to determine the quantity in gallons of asphalt cement used) converted from gallons to tons (megagrams) by the Engineer and certified for payment.

- a. If the asphalt cement price for the month is *greater* than the asphalt cement price for the month in which the project was let to contract, the contractor will be paid an amount calculated in accordance with the following formula:

$$PA = [((APM-APL)/APL)] \times TMT \times APL$$

- b. If the asphalt cement price for the month is *less* than the asphalt cement price for the month in which the project was let to contract, the Department will deduct an amount calculated in accordance with the following formula:

$$PA = [((APM-APL)/APL)] \times TMT \times APL$$

1. **“Monthly Asphalt Cement Price”**: The Department will determine the “Monthly Asphalt Cement Price” based on the following formulas:

Monthly Asphalt Cement Price = 100% Georgia Base Asphalt Price, Where;

GBAP = “Georgia Base Asphalt Price”, (in dollars/ton) is based on the arithmetic average posted price of PG asphalt cement as specified in Section 820, from the Department’s monthly survey obtained from approved asphalt cement suppliers of bituminous materials to the Department projects F.O.B. the suppliers terminal. However, the highest price and the lowest price are excluded from the calculation of price, GBAP.

2. **“Asphalt Cement Quantity Calculation”**: The calculation of asphalt cement quantity for each mix type will be based on the asphalt cement content (*AC %*) of the approved Job Mix Formula (JMF) as specified in Subsection 400.1.03.C. The following calculation formula will be used to determine asphalt cement quantity:

**EXHIBIT O**  
**CDBG FEDERAL/LOCAL PROJECT REQUIREMENTS**

**Section 109—Measurement and Payment**

---

Asphalt Cement Quantity = Hot Mix Asphaltic Concrete monthly total in tons (megagrams) per mix type certified for the payment x *AC (%)*

The Total Monthly Tonnage (TMT) of asphalt cement computed by the Engineer will be calculated as follows:

TMT = Sum of all asphalt cement quantities, including polymer modified asphalt binder and non-modified asphalt cement, based on the Hot Mix Asphaltic Concrete of the various mix types per ton (megagram)// Sum of all asphalt cement quantities used as bituminous tack coat converted from gallons to tons (megagrams)// Sum of all asphalt cement quantities used for bituminous surface treatment (total gallons of asphalt emulsion used, as measured from distributors, will be multiplied by a factor of 0.65 to determine the quantity in gallons of asphalt cement used) converted from gallons to tons (megagrams) by the Engineer certified for payment.

Asphalt Cement Price for the Month (APM) will be adjusted monthly. Price adjustments (PA) will be made monthly and all calculations for Price Adjustments shall be performed by the Engineer as specified in SOP-39 “Determination of Asphalt Cement Index and Asphalt Cement Price Adjustment”.

- B. Price Adjustment Trigger:** No price adjustment will be made on any project with less than 366 Calendar Days from the Contract Letting Date to the specified completion date. If the original Contract contains 366 Calendar Days or more, the Price Adjustment shall be made on quantities placed from the Contract Letting Date to the specified completion date.
- C. “Monthly Asphalt Cement Price”:** The Department will publish a “Monthly Asphalt Cement Price” based on the formula contained within this specification.
- D. “Other Restrictions”:**
1. No asphalt cement price adjustment will be made for cut-back, and emulsified asphalt when used for bituminous tack coat with Hot Mix Asphaltic Concrete Construction.
  2. There is a cap of 60% above the APL for any price adjustment.
  3. Unless specifically provided for by Supplemental Agreement or Contract Amendment, no positive Price Adjustments Asphalt Cement that result in a payment to the Contractor will be made after the original Contract Time has expired. Irrespective of any other provisions in the Contract, for purposes of this specification, “Contract Time” does not include any time extensions or Supplemental Agreements which affect the completion of the Contract. Negative Price Adjustments for Asphalt Cement for any work placed after the original Contract Time expires resulting in a return of funds to the Department will be made and shall be computed based on the Monthly Asphalt Cement Price at the time the Contract Time has expired or the Monthly Asphalt Cement Price at the time the Contract was let, whichever is less.
- E. Final Adjustment:** If there are differences between the final audited quantities and the sum of the quantities used to determine the asphalt cement adjustment, the Engineer will make a pro-rated increase or decrease in the price adjustment.

Payment for Price Adjustment will be made under:

Item No. 109	Price Adjustment- Asphalt Cement	\$ (+/-)
--------------	----------------------------------	----------

**EXHIBIT O**  
**CDBG FEDERAL/LOCAL PROJECT REQUIREMENTS**

1st Use: Nov 22, 2013  
Rev Oct 2014

**DEPARTMENT OF TRANSPORTATION**  
**STATE OF GEORGIA**

**SPECIAL PROVISION**

**Section 161—Control of Soil Erosion and Sedimentation**

---

*Add the following:*

**161.1 General Description**

This Work includes using control measures shown on the Plans, ordered by the Engineer, or as required during the life of the Contract to control soil erosion and sedimentation using any of the devices or methods referred to in this Section.

**161.1.01 Definitions**

Certified Personnel— certified personnel are defined as persons who have successfully completed the Level IA certification course approved by the Georgia Soil and Water Conservation Commission. For Department projects the certified person must also have successfully completed the Department’s WECS certification course.

Design Professional as defined in the current GAR100002 NPDES permit.

**161.1.02 Related References**

**A. Standard Specifications**

[Section 105—Control of Work](#)

[Section 106—Control of Materials](#)

[Section 107—Legal Regulations and Responsibility to the Public](#)

[Section 109—Measurement and Payment](#)

[Section 160—Reclamation of Material Pits and Waste Areas](#)

[Section 162—Erosion Control Check Dams](#)

[Section 163—Miscellaneous Erosion Control Items](#)

[Section 166—Restoration or Alteration of Lakes and Ponds](#)

[Section 170—Silt Retention Barrier](#)

[Section 171—Temporary Silt Fence](#)

[Section 205—Roadway Excavation](#)

[Section 434—Sand Asphalt Paved Ditches](#)

[Section 441—Miscellaneous Concrete](#)

[Section 603—Rip Rap](#)

[Section 700—Grassing](#)

[Section 710—Permanent Soil Reinforcing Mat](#)

[Section 715—Bituminous Treated Roving](#)

**EXHIBIT O**  
**CDBG FEDERAL/LOCAL PROJECT REQUIREMENTS**

[Section 716—Erosion Control Mats \(Blankets\)](#)

Erosion control measures contained in the Specifications include:

<b>Erosion Control Measure</b>	<b>Section</b>
Temporary Check Dams	<a href="#">163.3.05.J</a>
Bituminous Treated Mulch	<a href="#">700.3.05.G</a>
Concrete Paved Ditches	<a href="#">441</a>
Bituminous Treated Roving	<a href="#">715</a>
Erosion Control Mats (Blankets)	<a href="#">716</a>
Erosion Control Check Dams	<a href="#">162</a>
Grassing	<a href="#">700</a>
Maintenance of Temporary Erosion Control Devices	<a href="#">165</a>
Permanent Soil Reinforcing Mat	<a href="#">710</a>
Reclamation of Material Pits and Waste Areas	<a href="#">160</a>
Rip Rap	<a href="#">603</a>
Restoration or Alteration of Lakes and Ponds	<a href="#">166</a>
Sand-Asphalt Ditch Paving	<a href="#">434</a>
Sediment Basin	<a href="#">163.3.05.C</a>
Silt Control Gate	<a href="#">163.3.05.A</a>
Silt Retention Barrier	<a href="#">170</a>
Sod	<a href="#">700.3.05.H</a> & <a href="#">700.3.05.I</a>
Mulch	<a href="#">163</a>
Temporary Grassing	<a href="#">163.3.05.F</a>
Temporary Silt Fence	<a href="#">171</a>
Temporary Slope Drains	<a href="#">163.3.05.B</a>
Triangular Sediment Barrier	<a href="#">720</a>
Silt Filter Bag	<a href="#">719</a>
Organic & Synthetic Material Fiber Blanket	<a href="#">713</a>

**B. Referenced Documents**

Erosion and Sedimentation Pollution Control Plans (ESPCP)

**161.1.03 Submittals**

**A. Status of Erosion Control Devices**

The Worksite Erosion Control Supervisor (WECS) or certified personnel will inspect the installation and maintenance of the Erosion Control Devices according to [Subsection 167.3.05.B](#) and the ESPCP.

1. Submit all reports to the Engineer within 24 hours of the inspection. Refer to [Subsection 167.3.05.C](#) for report requirements.

**EXHIBIT O**  
**CDBG FEDERAL/LOCAL PROJECT REQUIREMENTS**

2. The Engineer will review the reports and inspect the Project for compliance and concurrence with the submitted reports.
3. The Engineer will notify the WECS or certified personnel of any additional items that should be added to the reports.
4. Items listed in the report requiring maintenance or correction shall be completed within 72 hours.

**B. Erosion and Sedimentation Pollution Control Plan**

1. Project Plans

An erosion and sedimentation pollution control plan (ESPCP) for the construction of the project will be provided by the Department. The ESPCP will be prepared for the various stages of construction necessary to complete the project.

If the Contractor elects to alter the stage construction from that shown in the plans, it will be the responsibility of the Contractor to have the plans revised and prepared in accordance with the current GAR100002 NPDES permit by a Design Professional to reflect all changes in Staging. This will also include any revisions to erosion and sedimentation control item quantities. If the changes affect the Comprehensive Monitoring Program (CMP), the Contractor will be responsible for any revisions to the CMP as well. Submit revised plans and quantities to the Engineer for review prior to land disturbing activities.

2. Haul Roads, Borrow Pits, Excess Material Pits, etc.

The Contractor is responsible for preparing erosion and sedimentation control plans for construction access roads and or haul roads borrow pits, excess material pits, etc (inside the Right of Way). Prepare these plans for all stages of construction and include the appropriate items and quantities. Submit these plans to the Engineer for review prior to land disturbing activities. These plans are to be prepared by a Design Professional.

If construction of access roads, haul roads, borrow pits, excess material pits, etc., (inside the Right of Way) encroach within the 25 foot (7.6 m) buffer along the banks of all state waters or within the 50 ft. (15 m) buffer along the banks of any state waters classified as a "trout stream", a state water buffer variance must be obtained by the Contractor prior to beginning any land disturbing activity in the stream buffer.

3. Erosion Control for Borrow and Excess Material Pits Outside the Right-of-Way

Erosion control for borrow pits and excess material pits outside the right of way is the responsibility of the Contractor. If borrow or excess material pits require coverage under the National Pollutant Discharge Elimination System permit (NPDES) or other permits or variances are required, submit a copy of all documentation required by the permitting agency to the Engineer. All costs associated with complying with local, state, and federal laws and regulations are the responsibility of the Contractor.

4. Culverts and Pipes

The ESPCP does not contain approved methods to construct a stream diversion or stream diversion channel. The Contractor shall prepare a diversion plan utilizing a Design Professional as defined in the current NPDES permit. See 161.3.05 G for additional information.

5. Temporary Asphalt or Concrete Batch Plants

In addition to the requirements of any applicable specifications, if the Department authorizes the temporary installation and use of any asphalt, concrete or similar batch plants within its right of way, the contractor shall submit an NOI to the Georgia Environmental Protection Division for coverage under the following NPDES permits; The Infrastructure permit for the construction of the plant, and the Industrial permit for the operation of, such a plant. The contractor shall submit the NOIs as both the Owner and the Operator.

**EXHIBIT O**  
**CDBG FEDERAL/LOCAL PROJECT REQUIREMENTS**

**161.2 Materials**

General Provisions 101 through 150.

**161.2.01 Delivery, Storage, and Handling**

General Provisions 101 through 150.

**161.3 Construction Requirements****161.3.01 Personnel****A. Duties of the Worksite Erosion Control Supervisor**

Before beginning Work, designate a Worksite Erosion Control Supervisor (WECS) to initiate, install, maintain, inspect, and report the condition of all erosion control devices as described in Sections 160 through 171 or in the Contract and ESPCP documents. The designee shall submit their qualifications on the Department provided resume form for consideration and approval. The contractor may utilize additional persons having WECS qualifications to facilitate compliance however, only one WECS shall be designated at a time.

The WECS and alternates shall:

- Be an employee of the Prime Contractor.
- Have at least one year of experience in erosion and sediment control, including the installation, inspection, maintenance and reporting of BMPs.
- Successfully completed the Georgia Soil and Water Conservation Commission Certification Course Level IA and the Department's WECS Certification Course.
- Provide phone numbers where the WECS can be located 24 hours a day.

The WECS' duties include the following:

1. Be available or have an approved representative available 24 hours a day and have access to the equipment, personnel, and materials needed to maintain erosion control and flooding control.
2. Inform the Engineer in writing whenever the alternate WECS assumes project responsibilities.
3. Ensure that erosion control deficiencies are corrected within seventy-two (72) hours or immediately during emergencies. Deficiencies that interfere with traffic flow, safety or downstream turbidity are to be corrected immediately.
4. During heavy rain, have the construction area patrolled day or night, any day of the week to quickly detect and correct erosion or flooding problems before they interfere with traffic flow, safety, or downstream turbidity.
5. Be on the site within three (3) hours after receiving notification of an emergency prepared to positively respond to the conditions encountered. The Department may handle emergencies without notifying the Contractor. The Department will recover costs for emergency maintenance work according to [Subsection 105.15, "Failure to Maintain Roadway or Structures."](#)
6. Maintain and submit for project record, "As-built" Erosion and Sedimentation Control Plans that supplement and graphically depict EC-1 reported additions and deletions of BMP's. The As-Built plans are to be always accessed and retained at a Department facility at all times.
7. Ensure that both the WECS and the alternate meet the criteria of this Subsection.
8. The WECS shall maintain a current certification card for the duration of the project. Recertification of the WECS will be required prior to the expiration date shown on the Certification card to remain as Certified Personnel and the WECS for the project.

**EXHIBIT O**  
**CDBG FEDERAL/LOCAL PROJECT REQUIREMENTS**

Failure of the WECS or alternate to perform the duties specified in the Contract, or whose performance, has resulted in a citation being received from a State or Federal Regulatory Agency, e.g., the Georgia Environmental Protection Division, shall result in one or more of the following;

- Suspension of the WECS' certification for a period of not less than 30 days
- Removal of the Contractor's project superintendent in accordance with Sections 105.05 and 108.05 for a period not less than 14 days
- Department wide revocation of the WECS certification for a period of 12 months
- Removal of the Contractor's project superintendent in accordance with Sections 105.05 and 108.05

**161.3.02 Equipment**

General Provisions 101 through 150.

**161.3.03 Preparation**

General Provisions 101 through 150.

**161.3.04 Fabrication**

General Provisions 101 through 150.

**161.3.05 Construction**

Coordinate the temporary and permanent erosion control provisions in this Specification with the permanent erosion control provisions in the Contract to ensure economical, effective, and continuous erosion control throughout the construction and post-construction periods.

At all times that land disturbing activity is underway, a person meeting the requirements of, "certified person" by the GSWCC (Level IA) must be on the project.

**A. Control Dust Pollution**

The contractor shall keep dust pollution to a minimum during any of the activities performed on the project. It may be necessary to apply water or other BMP's to roadways or other areas to reduce pollution.

**B. Perform Permanent or Temporary Grassing**

Perform permanent grassing, temporary grassing, or mulching on cut and fill slopes weekly (unless a shorter period is required by Subsection 107.23) during grading operations. When conditions warrant, the Engineer may require more frequent intervals.

Under no circumstances shall the grading (height of cut) exceed the height operating range of the grassing equipment. It is extremely important to obtain a cover, whether it is mulch, temporary grass, or permanent grass. Adequate mulch is a must.

When grading operations or other soil disturbing activities have stopped, perform grassing or erosion control as shown in the Plans, as shown in an approved Plan submitted by the Contractor, or as directed by the Engineer.

**C. Seed and Mulch**

Refer to Subsection [161.3.05.B, "Perform Permanent or Temporary Grassing"](#).



**EXHIBIT O**  
**CDBG FEDERAL/LOCAL PROJECT REQUIREMENTS**

**D. Implement Permanent or Temporary Erosion Control**

1. Silt fence shown along the perimeter, e.g., right of way, and sediment containment devices, e.g. sediment basins, shall be installed prior to or concurrently with clearing and grubbing operations.
2. Incorporate permanent erosion control features into the Project at the earliest practicable time, e.g., velocity dissipation, permanent ditch protection.
3. Use temporary erosion control measures to address conditions that developed during construction but were unforeseen during the design stage.
4. Use temporary erosion control measures when installation of permanent erosion control features cannot be accomplished.

The Engineer has the authority to:

- Limit the surface area of erodible earth material exposed by clearing and grubbing.
- Limit the surface area of erodible earth material exposed by excavation and borrow and fill operations.
- Limit the area of excavation, and embankment operations in progress to correspond with the Contractor's ability to keep the finish grading, mulching, seeding, and other permanent erosion control measures current.
- Direct the Contractor to provide immediate permanent or temporary erosion control to prevent contamination of adjacent streams or water courses, lakes, ponds, or other areas of water impoundment.

Such Work may include constructing items listed in the table in [Subsection 161.1.02.A, "Related References"](#) or other control devices or methods to control erosion.

**E. Erodible Area**

**NOTE: Never allow the surface area of erodible earth material exposed at one time to exceed 17 acres (7 ha) except as approved by the State Construction Engineer.**

The maximum of 17 acres (7 ha) of exposed erodible earth applies to the entire Project and to all combined operations as a whole, not to the exposed erodible earth of each individual operation.

Upon receipt of a written request from the contractor the State Construction Engineer, or his designee will review; the request, any justifications and the Project conditions for waiver of the 17 acres (7 ha) limitation.

If the 17-acre limitation is increased by the State Construction Engineer, the WECS shall not be assigned to another project in that capacity and should remain on site each work day that the exposed acreage exceeds 17 acres.

After installing temporary erosion control devices, e.g., grassing, mulching, stabilizing an area, and having it approved by the Engineer, that area will be released from the 17 acres (7 ha) limit.

**EXHIBIT O**  
**CDBG FEDERAL/LOCAL PROJECT REQUIREMENTS**

**F. Perform Grading Operations**

Perform the following grading operations:

1. Complete each roadway cut and embankment continuously, unless otherwise specified in the Contract or ordered by the Engineer.
2. Maintain the top of the earthwork in roadway sections throughout the construction stages to allow water to run off to the outer edges.
3. Provide temporary slope drain facilities with inlets and velocity dissipaters (straw bales, silt fence, aprons, etc.) to carry the runoff water to the bottom of the slopes. Place drains at intervals to handle the accumulated water.
4. Continue temporary erosion control measures until permanent drainage facilities have been constructed, pavement placed, and the grass on planted slopes stabilized to deter erosion.

**G. Perform Construction in Rivers and Streams**

Perform construction in river and stream beds as follows:

1. Unless otherwise agreed to in writing by the Engineer, restrict construction operations in rivers, streams, and impoundments to:
  - Areas where channel changes or access for construction are shown on the Plans to construct temporary or permanent structures.
2. If channel changes or diversions are not shown on the Plans, the Contractor shall develop diversion plans prepared in accordance with the current GAR100002 NPDES Infrastructure Construction permit utilizing a design professional as defined within the permit. The Engineer will review prepared diversion plans for content only and accepts no responsibility for design errors or omissions. Amendments will be made part of the project plans by attachment. Include any associated costs in the price bid for the overall contract. Any contract time associated with the submittal, or its review and subsequent response will not be considered for an extension of Contract time. All time associated with this subsection shall be considered incidental.
3. If additional access for construction or removal of work bridges, temporary roads/access or work platforms is necessary, and will require additional encroachment upon river or stream banks and bottoms, the contractor shall prepare a plan in accordance with the current GAR100002 NPDES Infrastructure Construction permit utilizing a design professional as defined within the permit. Plans should be submitted at least 12 weeks prior to the date the associated work is expected to begin. If necessary, the plan will be provided to the appropriate regulating authority, e.g., United States Army Corps of Engineers by the Department for consideration and approval. No work that impacts areas beyond what has been shown in the approved plans will be allowed to begin until written approval of the submitted plan has been provided by the Department. Approved plan amendments will be made part of the project plans by attachment. Include any associated costs in the price bid for the overall contract. Any contract time associated with the submittal, or its review and subsequent response will not be considered for an extension of Contract time. All time associated with this subsection shall be considered incidental.
4. Clear rivers, streams, and impoundments of the following as soon as conditions permit:
  - False work.
  - Piling that is to be removed.
  - Debris.
  - Other obstructions placed or caused by construction operations.
5. Do not ford live streams with construction equipment.
6. Use temporary bridges or other structures that are adequate for a 25-year storm for stream crossings. Include costs in the price bid for the overall contract.
7. Do not operate mechanized equipment in live streams except to construct channel changes or temporary or permanent structures, and to remove temporary structures, unless otherwise approved in writing by the Engineer.

**EXHIBIT O**  
**CDBG FEDERAL/LOCAL PROJECT REQUIREMENTS**

**H. State Water Buffers and Environmental Restrictions**

1. The WECS shall review the plans and contract documents for environmental restrictions, Environmentally Sensitive Areas (ESA), e.g., buffers, etc. prior to performing land disturbing activities.
2. The WECS shall ensure all parties performing land disturbing activities within the project limits are aware of all environmental restrictions.
3. Buffer delineation shall be performed prior to clearing, or any other land disturbing activities. Site conditions may require temporary delineation measures to be implemented prior to the installation of orange barrier/safety fencing. The means of temporary delineation shall have the Engineer's prior approval.
4. The WECS shall allow the Engineer to review the buffer delineation prior to performing any land disturbing activities, including but not limited to clearing, grubbing, and thinning of vegetation. Any removal and relocation of buffer delineation based upon the Engineer's review will not be measured for separate payment.
5. The WECS shall advise the Engineer of any surface water(s) encountered that are not shown in the plans. The WECS shall prevent land disturbing activities from occurring within surface water buffers until the Engineer provides approval to proceed.

**I. General Requirements**

**Projects that consist of asphalt resurfacing, shoulder reconstruction and/or shoulder widening; schedule and perform the construction of the project to comply with the following:**

After temporary and permanent erosion control devices are installed and the area permanently stabilized (temporary or permanent) and approved by the Engineer, the area may be released from the 1 acre (0.4 ha) limit.

The maximum of 1 acre (0.4 ha) of erodible earth applies to the entire project and to all combined operations, including borrow and excess material operations that are within the right of way, not 1 acre (0.4 ha) of exposed erodible earth for each operation.

**NOTE: Never allow the surface area of erodible earth material exposed at one time to exceed 1 acre (0.4 ha).**

1. Do not allow the disturbed exposed erodible area to exceed 1-acre (0.4 ha). This 1-acre (0.4 ha) limit includes all disturbed areas relating to the construction of the project including but not limited to slope and shoulder construction.
2. At the end of each working day, permanently stabilize all the area disturbed by slope and shoulder reconstruction to prevent any contamination of adjacent streams or other watercourses, lakes, ponds or other areas of water impoundment. For purposes of this Specification, the end of the working day is defined as when the construction operations cease. For example, 6:00 a.m. is the end of the working day on a project that allows work only between 9:00 p.m. and 6:00 a.m.)
3. Stabilize the cut and fill slopes and shoulder with permanent or temporary grassing and a Wood Fiber Blanket ([Section 713](#), Type II). Mulching is not allowed. Borrow pits, soil disposal sites and haul roads will not require daily applications of wood fiber blanket. The application rate for the Wood Fiber Blanket on shoulder reconstruction is the rate specified for Shoulders. For shoulder reconstruction, the ground preparation requirements of [Subsection 700.3.05.A.1](#) are waived. Preparation consists of scarifying the existing shoulders 4 to 6 in (100 to 150 mm) deep and leaving the area in a smooth uniform condition free from stones, lumps, roots, or other material.

**EXHIBIT O**  
**CDBG FEDERAL/LOCAL PROJECT REQUIREMENTS**

4. If a sudden rain event occurs that would not allow the Contractor to apply the Type II Wood Fiber Blanket per [Section 713](#), install Wood Fiber Blanket Type I per [Section 713](#) if directed by the Engineer. Wood Fiber Blanket Type I application is for emergency use only.

Install temporary grass or permanent grass according to seasonal limitations and Specifications. When temporary grass is used, use the overseeding method ([Subsection 700.3.05.E.4](#)) when planting permanent grass.

3. Remove and dispose of all material excavated for the trench widening operation at an approved soil disposal site by the end of each working day. When shoulder reconstruction is required, this material may be used to reconstruct the graded shoulder after all asphaltic concrete pavement has been placed.

4. Provide immediate permanent and/or temporary erosion control measures for borrow pits, soil disposal sites and haul roads to prevent any contamination of adjacent streams or other watercourses, lakes, ponds, or other areas of water impoundment.

5. Place asphalt in the trench the same day as the excavation occurs. Place asphalt or concrete in driveways and side roads being re-graded the same day as the excavation occurs. Stabilize any disturbed or exposed soil that is not covered with asphalt with a Wood Fiber Blanket (and grass seed). Payment will be made for the Wood Fiber Blanket and grass seed only if the shoulder has been constructed to final dimensions and grade and no further grading will be required.

6. Do not allow the grading (height of cut or fill) to exceed the operating range of the grassing equipment.

7. When grading operations or other soil disturbing activities are suspended, regardless of the reason, promptly perform all necessary permanent stabilization and/or erosion control work.

8. Use temporary erosion control measures to:

To correct conditions that develop during construction but were unforeseen during the design stage.

To use as needed before installing permanent erosion control features.

To temporarily control erosion that develops during normal construction practices but are not associated with permanent control features on the Project.

9. When conditions warrant, such as unfavorable weather (rain event), the Engineer may require more frequent intervals for this work.

#### **161.3.06 Quality Acceptance**

Before Final Acceptance of the Work, clean drainage structures within the project limits, both existing and newly constructed, and ensure that they are functioning properly. Costs to accomplish this work are incidental and shall be included in the overall bid for the Contract.

#### **161.3.07 Contractor Warranty and Maintenance**

Maintain the erosion control features installed to:

- Contain erosion within the limits of the right-of-way
- Control storm water discharges from disturbed areas.

Effectively install and maintain the erosion control features. Ensure these features contain the erosion and sediment within the limits of the rights of way and control the discharges of storm water from disturbed areas to meet all local, state, and federal requirements on water quality.

If a construction Project has separate contractors, the Prime Contractor shall maintain the erosion control features at grading sites as acceptable to the Engineer until the Contract is accepted. If any erosion control devices are damaged by any contractor either by neglect, by construction methods, or for any other reasons, including acts of nature, they shall be repaired within 24 hours by the Prime Contractor at no cost to the Department.

**EXHIBIT O**  
**CDBG FEDERAL/LOCAL PROJECT REQUIREMENTS**

### **161.4 Measurement**

Control of soil erosion and sedimentation is not measured separately for payment.

#### **161.4.01 Limits**

General Provisions 101 through 150.

### **161.5 Payment**

When no pay item is shown in the Contract, the requirements of this Specification and the Erosion Control Plan shall be in full effect. The cost of complying with these requirements will not be paid separately, but shall be included in the overall bid submitted with the exception of inspections performed by qualified personnel which will be included in Section 167.

When listed as a pay item in the Contract, payment will be made at the unit price bid for each item.

No payment will be made for erosion control outside the Right-of-Way or construction easements except as provided for by the Plans.

#### **161.5.01 Enforcement and Adjustments**

##### **A. Failure to Provide a WECS**

If a designated WECS is not maintained or if the Contractor does not comply with this Specification, cease activities except traffic control and erosion control work. Monies that are due or that may become due also may be withheld according to the Specifications.

##### **B. Failure to Submit Reports**

A non-refundable deduction will be taken from the schedule below whenever the WECS fails to submit completed reports required by [Subsection 167.3.05.C](#) in accordance with the provisions of this specification.

##### **C. Failure to Comply with Specifications**

If the Contractor fails to comply with any of the requirements of this Specification, all activities shall cease immediately except traffic control and erosion control related work.

Monies that are currently due or that may become due shall be withheld according to the specifications. In addition, nonrefundable monies shall be deducted from the contract as shown in the Schedule of Deductions table below. These deductions are in addition to any actions taken in the above subsections. Deductions assessed for uncorrected deficiencies shall continue until all corrections are completed to the satisfaction of the Engineer.

##### **D. Receipt of a Consent Order or Notice of Violation, etc.**

Regulatory enforcement actions will be resolved including at a minimum the following steps.

- The Department will perform an internal review of the alleged violations.
- The Department will then meet with the Contractor to review and further determine responsibilities for the alleged violations.
- The Department will then arrange to meet collectively with the regulatory agencies to negotiate resolutions and/or settlements.

**EXHIBIT O**  
**CDBG FEDERAL/LOCAL PROJECT REQUIREMENTS**

The Department does not waive any rights of the Contractor to resolve such matters however, in the event that regulatory agency communication is addressed jointly to the Department and to the contractor, the Department reserves the right to coordinate all communications, e.g., written correspondence, and to schedule jointly attended meetings with Regulatory agencies such that timely and accurate responses are known to the Department.

Such Orders or Notices may result in the assessment of Deductions from the table below for each day the condition remains non-compliant following an agreed remedy.

Monetary penalties for which the contractor is obligated because of regulatory enforcement may be withheld from future monies due the contractor.

Schedule of Deductions for Each Calendar Day of Erosion Control Deficiencies Initial Occurrence*		
Original Total Contract Amount		
From More Than	To and Including	Daily Charge
0	\$100,000	\$750
\$100,000	\$1,000,000	\$1125
\$1,000,000	\$5,000,000	\$2000
\$5,000,000	\$15,000,000	\$3000
\$15,000,000	-	\$5000

\*Continued non-compliance with the requirements of this specification may result in the doubling of the above tabulated Daily Charge.

Upon written request from the Contractor, the Engineer may allow limited activities to proceed concurrently proceed once significant portions of the corrective work have been completed. This authorization may be similarly rescinded if in the opinion of the Engineer corrective work is not being diligently pursued.

**EXHIBIT O**  
**CDBG FEDERAL/LOCAL PROJECT REQUIREMENTS**

1st Use: Nov 22, 2013  
Revised: May 22, 2015

**DEPARTMENT OF TRANSPORTATION**  
**STATE OF GEORGIA**

**SUPPLEMENTAL SPECIFICATION**

**Section 163—Miscellaneous Erosion Control Items**

---

*Delete Section 163 and substitute the following:*

**163.1 General Description**

This work includes constructing and removing:

- Silt control gates
- Temporary erosion control slope drains shown on the Plans or as directed.
- Temporary sediment basins.
- Sediment barriers and check dams.
- Rock filter dams.
- Stone filter berms.
- Stone filter rings.
- Temporary sediment traps.
- Other temporary erosion control structures shown on the Plans or directed by the Engineer.

This work also includes applying mulch (e.g., straw, hay, erosion control compost), and temporary grass.

**163.1.01 Related References**

**A. Standard Specifications**

[Section 109—Measurement and Payment](#)

[Section 161—Control of Soil Erosion and Sedimentation](#)

[Section 171—Temporary Silt Fence](#)

[Section 500—Concrete Structures](#)

[Section 603—Riprap](#)

[Section 700—Grassing](#)

[Section 711—Turf Reinforcement Matting](#)

[Section 716—Erosion Control Mats \(Slopes\)](#)

[Section 720 – Triangular Silt Barrier](#)

[Section 800—Coarse Aggregate](#)

[Section 801—Fine Aggregate](#)

[Section 822—Emulsified Asphalt](#)

[Section 860—Lumber and Timber](#)

[Section 863—Preservative Treatment of Timber Products](#)

[Section 881—Fabrics](#)

[Section 890—Seed and Sod](#)

[Section 893—Miscellaneous Planting Materials](#)

**EXHIBIT O**  
**CDBG FEDERAL/LOCAL PROJECT REQUIREMENTS**

**B. Referenced Documents**

AASHTO M252

AASHTO M294

**163.1.02 Submittals**

Provide written documentation to the Engineer as to the average weight of the bales of mulch.

**163.2 Materials**

Provide materials shown on the Plans, such as pipes, spillways, wood baffles, and other accessories including an anti-seep collar, when necessary. The materials shall remain the Contractor's property after removal, unless otherwise shown on the Plans.

Materials may be new or used; however, the Engineer shall approve previously used materials before use.

Materials shall meet the requirements of the following Specifications:

Material	Section
Mulch	<a href="#">893.2.02</a>
Temporary Silt Fence	<a href="#">171</a>
Concrete Aprons and Footings shall be Class A	<a href="#">500</a>
Riprap	<a href="#">603</a>
Temporary Grass	<a href="#">700</a>
Triangular Silt Barrier	<a href="#">720</a>
Lumber and Timber	<a href="#">860.2.01</a>
Preservative Treatment of Timber Products	<a href="#">863.1</a>
Corrugated Polyethylene Temporary Slope Drainpipe	AASHTO M252 or M294

**163.2.01 Delivery, Storage, and Handling**

General Provisions 101 through 150.

**163.3 Construction Requirements****163.3.01 Personnel**

General Provisions 101 through 150.

**163.3.02 Equipment**

General Provisions 101 through 150.

**163.3.03 Preparation**

General Provisions 101 through 150.

**163.3.04 Fabrication**

General Provisions 101 through 150.

**163.3.05 Construction****A. Silt Control Gates**

If silt control gates are required or are directed by the Engineer, follow these guidelines to construct them:

1. Clear and grade only that portion of the roadway within the affected drainage area where the drainage structure will be constructed.
2. Construct or install the drainage structure and backfill as required for stability.
3. Install the silt control gate at the inlet of the structure. Use the type indicated on the Plans.
4. Vary the height of the gate as required or as shown on the Plans.



**EXHIBIT O**  
**CDBG FEDERAL/LOCAL PROJECT REQUIREMENTS**

5. Finish grading the roadway in the affected drainage area. Grass and mulch slopes and ditches that will not be paved. Construct the ditch paving required in the affected area.
6. Keep the gate in place until the work in the affected drainage area is complete and the erodible area is stabilized.
7. Remove the Type 1 silt gate assembly by sawing off the wood posts flush with the concrete apron. Leave the concrete apron between the gate and the structure inlet in place. The gate shall remain the property of the Contractor.

**B. Temporary Slope Drains**

If temporary slope drains are required, conduct the roadway grading operation according to [Section 161](#) and follow these guidelines:

1. Place temporary pipe slope drains with inlets and velocity dissipaters (straw bales, silt fence, or aprons) according to the Plans.
2. Securely anchor the inlet into the slope to provide a watertight connection to the earth berm. Ensure that all connections in the pipe are leak proof.
3. Place temporary slope drains at a spacing of 350 ft (105 m) maximum on a 0% to 2% grade and at a spacing of 200 ft (60m) maximum on steeper grades, or more frequently as directed by the Engineer. Keep the slope drains in place until the permanent grass has grown enough to control erosion.
4. Remove the slope drains and grass from the disturbed area with permanent grass. However, the temporary slope drains may remain in place to help establish permanent grass if approved by the Engineer.

**C. Temporary Sediment Basins**

Construct temporary sediment basins according to the Plans at the required locations, or as modified by the Engineer.

1. Construct the unit complete as shown, including:
  - Grading
  - Drainage
  - Rip-rap
  - Spillways
  - Anti-seep collar
  - Temporary mulching and grassing on internal and external slopes.
  - Accessories to complete the basin.
2. When the sediment basin is no longer needed remove, and dispose of the remaining sediment.
3. Remove the sediment basin. Grade to drain and restore the area to blend with the adjacent landscape.
4. Mulch and permanently grass the disturbed areas according to [Section 700](#).

**D. Sediment Barriers**

Construct sediment barriers according to the Plan details.

The following items may be used for sediment barriers

1. Type A Silt Fence.
2. Type C Silt Fence.
3. Rectangular, mechanically produced, and standard-sized baled wheat straw.
4. Triangular Silt Barrier.
5. Synthetic Fiber: Use synthetic fiber bales of circular cross section at least 18 in (450 mm) in diameter. Use synthetic bales of 3 ft or 6 ft (0.9 m or 1.8 m) in length that are capable of being linked together to form a continuous roll of the desired total length. Use bales that are enclosed in a geotextile fabric and that contain a pre-made stake hole for anchoring.
6. Coir: Use coir fiber bales of circular cross section at least 16" (400mm) in diameter. Use coir bales of 10 ft, 15 ft, or 20 ft (3 m, 4.5 m, or 6 m) in length. Use coir baled with coir twine netting with 2 in X 2 in (50 mm X 50 mm) openings. Use coir bales with a dry density of at least 7 lb./ft<sup>3</sup> (112 kg/m<sup>3</sup>). Anchor in place with 2 in X 4 in (50 mm X 100 mm) wooden wedges with a 6 in (150 mm) nail at the top. Place wedges no more than 36 in (900 mm) apart.
7. Excelsior: Use curled aspen excelsior fiber with barbed edges in circular bales of at least 18 in (450 mm) in diameter and nominally 10 ft (3 m) in length. Use excelsior baled with polyester netting with 1 in X 1 in (25 mm by 25 mm) triangular openings. Use excelsior bales with a dry density of at least 1.4 lb./ft<sup>3</sup> (22 kg/m<sup>3</sup>). Anchor in place with 1 in (25 mm) diameter wooden stakes driven through the netting at intervals of no more than 2 ft (600 mm).

**EXHIBIT O**  
**CDBG FEDERAL/LOCAL PROJECT REQUIREMENTS**

8. Compost Filter Sock: Use general use compost (see Subsection 893.2.02.A.5.b) in circular bales at least 18 in diameter. Use compost baled with photo-degradable plastic mesh 3 mils thick with a maximum 0.25 in X 0.25 in (6 mm X 6 mm) openings. Anchor in place with 1 in (25 mm) diameter wooden stakes driven through the netting at intervals of no more than 2 ft (600 mm). The sock shall be dispersed on site when no longer required, as determined by the Engineer. Do not use Compost Filter Socks in areas where the use of fertilizer is restricted.
9. Compost Filter Berm: Use erosion control compost (see [Subsection 893.2.02](#)) to construct a noncompacted 1.5 ft to 2 ft (450 mm to 600 mm) high trapezoidal berm which is approximately 2 ft to 3 ft (600 mm to 1 m) wide at the top and minimum 4 ft (1.2 m) wide at the base. Do not use Compost Filter Berms in areas where the use of fertilizer is restricted.  
The construction of the compost filter berm includes the following:
  - a. Keeping the berm in a functional condition.
  - b. Installing additional berm material when necessary.
  - c. Removing the berm when no longer required, as determined by the Engineer. At the Engineer's discretion, berm material may be left to decompose naturally, or distributed over the adjacent area.

**E. Other Temporary Structures**

When special conditions occur during the design stage, the Plans may show other temporary structures for erosion control with required materials and construction methods.

**F. Temporary Grass**

Use a quick-growing species of temporary grass such as rye grass, millet, or a cereal grass suitable to the area and season.

Use temporary grass in the following situations:

- When required by the Specifications or directed by the Engineer to control erosion where permanent grassing cannot be planted.
- To protect an area for longer than mulch is expected to last (60 calendar days), plant temporary grass as follows:
  1. Use seeds that conform to Subsection 890.2.01, "Seed." Perform seeding according to [Section 700](#); except use the minimum ground preparation necessary to provide a seed bed if further grading is required.
  2. Prepare areas that require no further grading according to Subsection 700.3.05.A, "Ground Preparation." Omit the lime unless the area will be planted with permanent grass without further grading. In this case, apply the lime according to [Section 700](#).
  3. Apply mixed grade fertilizer at 400 lbs./acre (450 kg/ha). Omit the nitrogen. Mulch (with straw or hay) temporary grass according to [Section 700](#). (Erosion control compost Mulch will not be allowed with grassing.)
  4. Before planting permanent grass, thoroughly plow and prepare areas where temporary grass has been planted according to Subsection 700.3.05.A, "Ground Preparation".
  5. Apply Polyacrylamide (PAM) to all areas that receive temporary grassing.
  6. Apply PAM (powder) before grassing or PAM (emulsion) to the hydro-seeding operation.
  7. Apply PAM according to manufacturer specifications.
  8. Use only anionic PAM.

For projects that consist of shoulder reconstruction and/or shoulder widening, refer to Section 161.3.05H for Wood Fiber Blanket requirements.

**G. Mulch**

When staged construction or other conditions prevent completing a roadway section continuously, apply mulch (straw or hay or erosion control compost) to control erosion. Mulch may be used without temporary grassing for 60 calendar days or less. Areas stabilized with only mulch (straw/hay) shall be planted with temporary grass after 60 calendar days.

Apply mulch as follows:

1. Mulch (Hay or Straw) - Without Grass Seed
  - a. Uniformly spread the mulch over the designated areas from 2 in to 4 in (50 mm to 100 mm) thick.
  - b. After spreading the mulch, walk in the mulch by using a tracked vehicle (preferred method), empty sheep foot roller, light disking, or other means that preserves the finished cross section of the prepared areas. The Engineer will approve of the method.

**EXHIBIT O**  
**CDBG FEDERAL/LOCAL PROJECT REQUIREMENTS**

- c. Place temporary mulch on slopes as steep as 2:1 by using a tracked vehicle to imbed the mulch into the slope.
  - d. When grassing operations begin, leave the mulch in place, and plow the mulch into the soil during seed bed preparation. The mulch will become beneficial plant food for the newly planted grass.
2. Erosion control compost - Without Grass Seed
- a. Uniformly spread the mulch (erosion control compost) over the designated areas 2 in (50 mm) thick.
  - b. When rolling is necessary, or directed by the Engineer, use a light corrugated drum roller.
  - c. When grassing operations begin, leave the mulch in place, and plow the mulch into the soil during seed bed preparation. The mulch will become beneficial plant food for the newly planted grass.
  - d. Plant temporary grass on area stabilized with mulch (erosion control compost) after 60 calendar days.
  - e. Do not use Erosion Control Compost in areas where the use of fertilizer is restricted.

**H. Miscellaneous Erosion Control Items Not Shown on the Plans**

When conditions develop during construction that were unforeseen in the design stage, the Engineer may direct the Contractor to construct temporary devices such as but not limited to:

- Bulkheads
- Sump holes
- Half round pipe for use as ditch liners
- U-V resistant plastic sheets to cover critical cut slopes.

The Engineer and the Contractor will determine the placement to ensure erosion control in the affected area.

**I. Diversion Channels**

When constructing a culvert or other drainage structure in a live stream that requires diverting a stream, construct a diversion channel.

**J. Check Dams**

Check dams are constructed of the following materials;

- Stone plain rip-rap according to [Section 603](#) (Place woven plastic filter fabric on ditch section before placing rip-rap.)
- Sand bags as in [Section 603](#) without Portland cement
- Baled wheat straw
- Compost filter socks
- Fabric (Type C silt fence)

Check dams shall be constructed according to plan details and shall remain in place until the permanent ditch protection is in place or being installed and the removal is approved by the Engineer.

**K. Construction Exits**

Locate construction exits at any point where vehicles will be leaving the project onto a public roadway. Install construction exits at the locations shown in the plans and in accordance with plan details.

**L. Retrofits**

Add the retrofit device to the permanent outlet structure as shown on the Plan details.

When all land disturbing activities that would contribute sediment-laden runoff to the basin are complete, clean the basin of sediment and stabilize the basin area with vegetation.

When the basin is stabilized, remove the retrofit device from the permanent outlet structure of the detention pond.

**M. Inlet Sediment Traps**

Inlet sediment traps consist of a temporary device placed around a storm drain inlet to trap sediment. An excavated area adjacent to the sediment trap will provide additional sediment storage.

Inlet sediment traps may be constructed of Type C silt fence, plastic frame and filter, hay bales, baffle box, or other filtering materials approved by the Engineer. Construct inlet sediment traps according to the appropriate specification for the material selected for the trap. Place inlet sediment traps as shown on the Plans or as directed by the Engineer.

**EXHIBIT O**  
**CDBG FEDERAL/LOCAL PROJECT REQUIREMENTS**

**N. Rock Filter Dams**

Construct rock filter dams of the material selected as shown in the approved erosion and sediment control plan. Construct and place this item in accordance with the approved erosion control construction detail(s) and Standard Specification [Section 603](#).

Rock filter dams shall remain in place until the permanent ditch protection is in place or is being installed and their removal is approved by the Engineer.

**O. Stone Filter Berms**

Construct stone filter berms of the material selected as shown in the approved erosion and sediment control plan. Construct and place this item in accordance with the approved erosion control construction detail(s) and Standard Specification [Section 603](#).

Stone filter berms shall remain in place until the permanent slope protection is in place or is being installed and their removal is approved by the Engineer.

**P. Stone Filter Rings**

Construct stone filter rings of the material selected as shown in the approved erosion and sediment control plan. Construct and place this item in accordance with the approved erosion control construction detail(s) and Standard Specification [Section 603](#).

A stone filter ring shall remain in place until final stabilization of the area which drains toward it is achieved and its removal is approved by the Engineer.

**Q. Temporary Sediment Traps**

Construct temporary sediment traps of the material selected as shown in the approved erosion and sediment control plan. Construct and place this item in accordance with the approved erosion control construction detail(s) and Standard Specification [Section 603](#).

A temporary sediment trap shall remain in place until final stabilization of the area which drains toward it is achieved and its removal is approved by the Engineer.

**163.3.06 Quality Acceptance**

General Provisions 101 through 150.

**163.3.07 Contractor Warranty and Maintenance**

General Provisions 101 through 150.

**163.4 Measurement****A. Silt Control Gates**

Silt control gates are measured for payment by the entire structure constructed at each location complete in place and accepted. Silt control gates constructed at the inlet of multiple lines of drainage structures are measured for payment as a single unit.

**B. Temporary Slope Drains**

Temporary slope drains are measured for payment by the linear foot (meter) of pipe placed. When required, the inlet spillway and outlet apron and/or other dissipation devices are incidental and not measured separately.

**C. Temporary Sediment Basins**

Temporary sediment basins are measured for payment by the entire structure complete, including construction, maintenance, and removal. Temporary grassing for sediment basins is measured separately for payment. Measurement also includes:

- Earthwork
- Drainage
- Spillways
- Baffles
- Riprap
- Final cleaning to remove the basin.

**EXHIBIT O**  
**CDBG FEDERAL/LOCAL PROJECT REQUIREMENTS**

**D. Sediment Barriers**

Sediment barriers are measured by the linear foot (meter).

**E. Other Temporary Structures**

Other temporary structures are not measured for payment. Costs for the entire structure complete, including materials, construction (including earthwork), and removal is included in the price bid for the drainage structure or for other Contract items.

**F. Temporary Grass**

Temporary grass is measured for payment by the acre (hectare). Lime, when required, is measured by the ton (megagram). Mulch and fertilizer are measured separately for payment.

**G. Mulch**

Mulch (straw or hay, or erosion control compost) is measured for payment by the ton (megagram).

**H. Miscellaneous Erosion Control Items Not Shown on the Plans**

These items are not measured for payment. The cost for construction, materials, and removal is included in the price bid for other contract items.

**I. Diversion Channels**

Diversion channels are not measured for payment. The cost for the entire structure complete, including materials, construction (including earthwork), and removal is included in the price bid for the drainage structure or for other contract items.

**J. Check Dams**

Stone, sandbags, baled wheat straw, and compost filter sock check dams are measured per each, which includes all work necessary to construct the check dam including woven plastic filter fabric placed beneath stone check dams. Fabric check dams are measured per linear foot.

**K. Construction Exits**

Construction exits are measured per each which will include all work necessary to construct the exit including the required geotextile fabric placed beneath the aggregate.

**L. Retrofits**

Retrofit will be measured for payment per each. The construction of the detention pond and permanent outlet structure will be measured separately under the appropriate items.

**M. Inlet Sediment Traps**

Inlet sediment traps, regardless of the material selected, are measured per each which includes all work necessary to construct the trap including any incidentals and providing the excavated area for sediment storage.

**N. Rock Filter Dams**

Rock filter dams are measured for payment per each required. This includes the entire structure at each location and all the work necessary for construction.

**O. Stone Filter Berms**

Stone filter berms are measured for payment per linear foot (meter) required. This includes the entire structure at each location and all the work necessary for construction.

**P. Stone Filter Rings**

Stone filter rings are measured for payment per each required. This includes the entire structure at each location and all the work necessary for construction.

**Q. Temporary Sediment Traps**

Temporary sediment traps are measured for payment per each required. This includes the entire structure at each location and all the work necessary for construction.

**EXHIBIT O**  
**CDBG FEDERAL/LOCAL PROJECT REQUIREMENTS**

**163.4.01 Limits**

General Provisions 101 through 150.

**163.5 Payment****A. Silt Control Gates**

The specified silt control gates are paid for at the Contract Unit Price per each. Payment is full compensation for:

- Furnishing the material and labor
- Constructing the concrete apron as shown on the Plans
- Excavating and backfilling to place the apron.
- Removing the gate

**B. Temporary Slope Drains**

Temporary slope drains are paid for by the linear foot (meter). Payment is full compensation for materials, construction, removal (if required), inlet spillways, velocity dissipaters, and outlet aprons.

When temporary drain inlets and pipe slope drains are removed, they remain the Contractor's property and may be reused or removed from the Project as the Contractor desires. Reused pipe or inlets are paid for the same as new pipe or inlets.

**C. Temporary Sediment Basins**

Temporary sediment basins, measured according to [Subsection 163.4.C "Measurement,"](#) are paid for by the unit, per each, for the type specified on the Plans. Price and payment are full compensation for work and supervision to construct, and remove the sediment basin, including final clean-up.

**D. Sediment Barriers**

Sediment barriers are paid by the linear foot (meter). Price and payment are full compensation for work and supervision to construct, and remove the sediment barrier, including final clean-up.

**E. Other Temporary Structures**

Other temporary structures are not measured for payment. Costs for the entire structure complete, including materials, construction (including earthwork), and removal is included in the price bid for the drainage structure or for other Contract items.

**F. Temporary Grass**

Temporary grass is paid for by the acre (hectare). Payment is full compensation for all equipment, labor, ground preparation, materials, wood fiber mulch, polyacrylamide, and other incidentals. Lime (when required) is paid for by the ton (megagram). Mulch and fertilizer are paid for separately.

**G. Mulch**

Mulch is paid for by the ton. Payment is full compensation for all materials, labor, maintenance, equipment, and other incidentals.

The weight for payment of straw or hay mulch will be the product of the number of bales used and the average weight per bale as determined on certified scales provided by the contractor or state certified scales. Provide written documentation to the Engineer stating the average weight of the bales.

The weight of erosion control compost mulch will be determined by weighing each loaded vehicle on the required motor truck scale as the material is hauled to the roadway, or by using recorded weights if a digital recording device is used.

The contractor may propose other methods of providing the weight of the mulch to Engineer for approval.

**H. Miscellaneous Erosion Control Items Not Shown on the Plans**

These items are not paid for separately. They are included in the price bid for other contract items.

**I. Diversion Channel**

Diversion channels are not paid for separately. They are included in the price bid for other contract items.

**EXHIBIT O**  
**CDBG FEDERAL/LOCAL PROJECT REQUIREMENTS**

**J. Check Dams**

Payment is full compensation for all materials, construction, and removal. Stone plain rip-rap, sandbag, baled wheat straw, or compost filter socks check dams are paid for per each. The required woven filter fabric required under each stone check dam-is included in the bid price. Fabric check dams are paid for per linear foot.

**K. Construction Exits**

Construction exits are paid for per each. Payment is full compensation for all materials including the required geotextile, construction, and removal.

**L. Retrofits**

This item is paid for at the Contract Unit Price per each. Payment is full compensation for all work, supervision, materials (including the stone filter), labor and equipment necessary to construct and remove the retrofit device from an existing or proposed detention pond outlet structure.

**M. Inlet Sediment Traps**

Inlet sediment traps are paid per each. Payment is full compensation for all materials, construction, and removal.

**N. Rock Filter Dams**

Rock filter dams are paid per each. Payment is full compensation for all materials, construction, and removal for each. Clean reused stone Type 3 rip-rap and #57 stone are paid for on the same basis as new items. Plastic woven filter fabric is required under rock filter dams and is included in the price bid for each.

**O. Stone Filter Berms**

Stone filter berms are paid for per linear foot (meter). Payment is full compensation for all materials, construction, and removal for each. Clean reused stone Type 3 rip-rap and #57 stone are paid for on the same basis as new items. Plastic woven filter fabric is required under rock filter berms and is included in the price bid for linear foot (meter).

**P. Stone Filter Rings**

Stone filter rings are paid for per each. Payment is full compensation for all materials, construction, and removal for each. Clean reused stone Type 3 rip-rap and #57 stone are paid for on the same basis as new items. Plastic woven filter fabric is required under stone filter rings and is included in the price bid for each.

**Q. Temporary Sediment Traps**

Temporary sediment traps are paid for payment per each required. This includes the entire structure at each location and all the work necessary for construction.

The items in this section (except temporary grass and mulch) are made as partial payments as follows:

- When the item is installed and put into operation the Contractor will be paid 75 percent of the Contract price.
- When the Engineer instructs the Contractor that the item is no longer required and is to remain in place or is removed, whichever applies, the remaining 25 percent will be paid.

Temporary devices may be left in place at the Engineer's discretion at no change in cost. Payment for temporary grass will be made based on the number of acres (hectares) grassed. Mulch will be based on the number of tons (megagrams) used.

**EXHIBIT O**  
**CDBG FEDERAL/LOCAL PROJECT REQUIREMENTS**

Payment is made under:

Item No. 163	Construct and remove silt control gates	Per each
Item No. 163	Construct and remove temporary pipe slope drains	Per linear foot (meter)
Item No. 163	Construct and remove temporary sediment barriers	Per linear foot (meter)
Item No. 163	Construct and remove sediment basins	Per each
Item No. 163	Construct and remove check dams except fabric dams	Per each
Item No. 163	Construct and remove fabric check dams	Per linear foot (meter)
Item No. 163	Construct and remove construction exits.	Per each
Item No. 163	Construct and remove retrofits	Per each
Item No. 163	Construct and remove rock filter dams	Per each
Item No. 163	Construct and remove stone filter berms	Per linear foot (meter)
Item No. 163	Construct and remove stone filter rings	Per each
Item No. 163	Construct and remove inlet sediment traps	Per each
Item No. 163	Construct and remove temporary sediment traps	Per each
Item No. 163	Temporary grass	Per acre (hectare)
Item No. 163	Mulch	Per ton (megagram)

**163.5.01 Adjustments**

General Provisions 101 through 150.



**EXHIBIT O**  
**CDBG FEDERAL/LOCAL PROJECT REQUIREMENTS**

1<sup>st</sup> Use : Nov 22, 2013  
 Revised: August 27, 2015  
 Revised: January 22, 2016

**DEPARTMENT OF TRANSPORTATION**  
**STATE OF GEORGIA**  
**SUPPLEMENTAL SPECIFICATION**  
**Section 167—Water Quality Monitoring**

---

*Delete 167 and substitute the following:*

**167.1 General Description**

This Specification establishes the Contractor’s responsibility to meet the requirements of Part IV of the National Pollutant Discharge Elimination System (NPDES) Infrastructure Permit No. GAR100002. In the case of differing requirements between this specification and the Permit, whichever is the more stringent requirement shall be adhered to.

**167.1.01 Definitions**

Certified Personnel are defined as persons who have successfully completed the appropriate certification course approved by the Georgia Soil and Water Conservation Commission. For Department projects the certified person must also have successfully completed the Department’s WECS certification course.

Water Quality Monitoring as used within this specification, the term “monitoring” shall be inclusive of the acts of detecting, noting, discerning, observing, etc. for the purpose of gauging compliance with the GAR100002.

Qualifying Rainfall Sampling Event means that which is defined in the current GAR1000002, Part IV.D.6.d(3).

**167.1.02 Related References**

**A. Standard Specifications**

Section 161—Control of Soil Erosion and Sedimentation

**B. Referenced Documents**

NPDES Infrastructure Permit No. GAR100002

GDOT WECS Seminar

EPD Rule Chapter 391-3-7

GSWCC Certification Level IA Course

OCGA 12-7-1

**167.1.03 Submittals**

General Provisions 101 through 150

**167.2 Materials**

General Provisions 101 through 150.

**167.2.01 Delivery, Storage, and Handling**

**EXHIBIT O**  
**CDBG FEDERAL/LOCAL PROJECT REQUIREMENTS**

General Provisions 101 through 150.

### **167.3 Construction Requirements**

#### **167.3.01 Personnel**

Use GSWCC level IA certified and WECS certified personnel to perform all sampling, inspections, and rainfall data collection. Use the Contractor-designated WECS or select a prequalified consultant from the Qualified Consultant List (QCL) to perform water quality sampling, inspections, and rainfall data collection.

The Contractor is responsible for having a copy of the GAR100002 Permit onsite at all times.

#### **167.3.02 Equipment**

Provide equipment necessary to complete the Work or as directed by the Engineer.

#### **167.3.03 Preparation**

General Provisions 101 through 150.

#### **167.3.04 Fabrication**

General Provisions 101 through 150.

#### **167.3.05 Construction**

##### **A. General**

Perform inspections, rainfall data collection, testing of samples, and reporting the test results on the project according to the requirements in Part IV of the GAR100002 and this Specification.

Take samples manually or use automatic samplers, according to the GAR100002. Note that GAR100002 requires the use of manual sampling or rising stage sampling for qualifying events that occur after the first instance of the automatic sampler not being activated during a qualifying event. Analyze all samples according to the Permit, regardless of the method used to collect the samples.

If samples are analyzed in the field using portable turbidimeters, the sampling results shall state they are being used and a digital readout of NTUs is what is provided.

Submit bench sheets, work sheets, etc., when using portable turbidimeters. There are no exceptions to this requirement.

Perform required inspections and submit all reports required by this Specification within the time frames specified. Failure to perform the inspections within the time specified will result in the cessation of all construction activities with the exception of traffic control and erosion control. Failure to submit the required reports within the times specified will result in non-refundable deductions as specified in Subsection 161.5.01.B.

##### **B. Water Quality Inspections**

The Department will provide one copy of the required inspection forms for use and duplication. Inspection forms may change during the contract to reflect regulatory agency needs or the needs of the Department. Any costs associated with the change of inspection forms shall be considered incidental and shall be borne by the Contractor. Alternate formats of the provided forms may be created, used and submitted by the Contractor

**EXHIBIT O**  
**CDBG FEDERAL/LOCAL PROJECT REQUIREMENTS**

provided the required content and/or data fields and verbatim certification statements from the Department's current forms are included.

The Engineer shall inspect the installation and condition of each erosion control device required by the erosion control plan within seven days after initial installation. This inspection is performed for each stage of construction when new devices are installed. The WECS shall ensure all installation deficiencies reported by the Engineer are corrected within two business days.

Ensure the inspections of the areas listed below are conducted by certified personnel and at the frequencies listed. Document all inspections on the appropriate form provided by the Department.

1. Daily (when any work is occurring):

Conduct inspections on the following areas:

- a. Petroleum product storage, usage, and handling areas for spills or leaks from vehicles or equipment
- b. All locations where vehicles enter/exit the site for evidence of off-site sediment tracking.

Continue these inspections until a Notice of Termination (NOT) is submitted and use the daily inspection forms.

2. Weekly and after Rainfall Events:

Conduct inspections on these areas every seven calendar days and within twenty-four hours after the end of a rainfall event that is 0.5 in (13 mm) or greater (unless such storm ends after 5:00 PM on any Friday or any non-working Saturday, non-working Sunday or any non-working Federal holiday in which case the inspection shall be completed by the end of the next business day and/or working day, whichever occurs first):

- a. Disturbed areas not permanently stabilized
- b. Material storage areas that are exposed to precipitation
- c. Structural control measures, Best Management Practices (BMPs) to ensure they are operating correctly
- d. Water quality sampling locations and equipment
- e. Discharge locations or points, e.g., outfalls and drainage structures that are accessible to determine if erosion control measures are effective in preventing significant impacts to receiving waters

Continue these inspections until all temporary BMPs are removed and a NOT is submitted. Use the EC-1 Form.

3. Monthly:

Once per month, inspect all areas of the site that have undergone final stabilization or have established a crop of annual vegetation and a seeding of target perennials appropriate for the region. Look for evidence of sediments or pollutants entering the drainage system and or receiving water. Inspect all permanent erosion control devices remaining in place to verify the maintenance status and that the devices are functioning properly. Inspect discharge locations or points, e.g., outfalls, drainage structures, that are accessible to determine if erosion control measures are effective in preventing significant impacts to receiving waters.

Continue these inspections until the Notice of Termination is submitted and use the monthly inspection form.

**C. Water Quality Sampling**

**EXHIBIT O**  
**CDBG FEDERAL/LOCAL PROJECT REQUIREMENTS**

When the sampling location is a receiving water, the upstream and downstream samples are taken for comparison of NTU values. When the sampling location is an outfall, a single sample is taken to be analyzed for its absolute NTU value.

**D. Reports**

1. Inspection Reports:

Summarize the results of inspections noted above in writing on the appropriate Daily, Weekly, Monthly, or EC-1 form provided by the Department and includes the following information:

- Date(s) of inspection
- Name of certified personnel performing inspection
- Construction phase
- Status of devices
- Observations
- Action taken in accordance with Part IV.D.4.a.(5) of the GAR100002 Permit
- Signature of personnel performing the inspection
- Any instance of non-compliance

When the report does not identify any non-compliance instances, the inspection report shall contain a statement that the best management practices comply with the Erosion, Sedimentation, and Pollution Control Plan. (See the EC-1 form.)

The reports shall be made and retained at the site or be readily available at a designated alternate location until the entire site or that portion of a construction project that has been phased has undergone final stabilization and a Notice of Termination is submitted to the Georgia Department of Natural Resources Environmental Protection Division (GAEPD). Such reports shall be readily available by the end of the second business day and/or working day and shall identify all incidents of best management practices that have not been properly installed and/or maintained as described in the Plan. The inspection form certification sheet shall be signed by the project WECS and the inspector performing inspections on behalf of the WECS (if not the same person). Submit all inspection reports to the Engineer within twenty-four hours of the inspection. The Engineer will review the submitted reports to determine their accuracy. The Engineer will notify the certified personnel of any additional items that should be added to the inspection report.

Correct any items listed in the inspection report requiring routine maintenance within seventy-two (72) hours of notification or immediately during perimeter BMP failure emergencies. Deficiencies that interfere with traffic flow, safety, or downstream turbidity are to be corrected as soon as practical but in no case later than seven (7) calendar days following the inspection.

Assume responsibility for all costs associated with additional sampling as specified in Part IV.D.6.d.3.(c) of the GAR100002 if either of these conditions arises:

- BMP's shown in the Plans are not properly installed and maintained, or
- BMP's designed by the Contractor are not properly designed, installed and maintained.

2. Sampling Reports

a. All sampling shall be performed in accordance with the requirements of the GAR100002 Permit for the locations identified in the ESPCP approved by the Department.

b. Report Requirements

Include in all reports, the following certification statement, signed by the WECS or consultant providing sampling on the project:

**EXHIBIT O**  
**CDBG FEDERAL/LOCAL PROJECT REQUIREMENTS**

“I certify under penalty of law that this report and all attachments were prepared under my direct supervision in accordance with a system designed to assure that certified personnel properly gather and evaluate the information submitted. Based on my inquiry of the person or persons who manage the system, or those persons directly responsible for gathering the information, the information is, to the best of my knowledge and belief, true, accurate and complete. I am aware that there are significant penalties for submitting false information, including the possibility of fine and imprisonment for knowing violations.”

When a rainfall event requires a sample to be taken, submit a report of the sampling results to the Engineer within seven working days of the date the sample was obtained. Include the following information in each report:

- 1) Date and time of sampling
  - 2) Name of certified person(s) who performed the sampling and analyses.
  - 3) Date the analyses were performed
  - 4) Time the analyses were initiated
  - 5) Rainfall amount on the sampling date (sampling date only)
  - 6) NTU of each sample & analytical method
  - 7) Location where each sample was taken (station number and left or right offset)
  - 8) Identification of whether a sample is a receiving-water sample or an outfall sample
  - 9) Project number and county
  - 10) References and written procedures, whenever available, for the analytical techniques or methods used: whether the samples were taken by automatic sampler, rising-stage sampler, or manually (grab sample)
  - 11) The results of such analyses, including the bench sheets, instrument readouts, computer disks or tapes, etc., used to determine these results
  - 12) A clear note if a sample exceeds 1000 NTUs by writing “exceeds 1000 NTUs” prominently upon the report.
- c. Report Requirements with No Qualifying Rainfall Events
- In the event a qualifying rainfall event does not produce a discharge to sample, or sampling is “impossible”, as defined in the GAR100002 Permit, a written justification must be included in the report as required at Part IV.D.4.a.(6) of the GAR100002 Permit.
- d. Sampling Results
- Provide sampling results to the Project Engineer within 48 hours of the samples being analyzed. This notification may be verbal or written. This notification does not replace the requirement to submit the formal summary to the Engineer within 7 working days of the samples being collected. The Engineer will ensure submission of the sampling report to GAEPD by the 15<sup>th</sup> of the month following the sampling results as per the GAR100002 Permit. The WECS will be held accountable for delayed delivery to the Department which results in late submissions to EPD resulting in enforcement actions.

3. Rainfall Data Reports:

Record the measurement of rainfall once each twenty-four-hour period, except for non-working Saturdays, non-working Sundays and non-working Federal Holidays until a Notice of Termination is submitted. Project rain gauges and those used to trigger the automatic samplers are to be emptied after every rainfall event. This will prevent a cumulative effect and prevent automatic samplers from taking samples even though the rainfall event is not a qualifying event. The daily rainfall data supplied by the WECS to the Engineer will be the official rainfall data for the project.

**167.3.06 Quality Acceptance**

General Provisions 101 through 150.

**EXHIBIT O**  
**CDBG FEDERAL/LOCAL PROJECT REQUIREMENTS**

**167.3.07 Contractor Warranty and Maintenance**

General Provisions 101 through 150.

**167.4 Measurement**

Water Quality Inspections in accordance with the inspection and reports sub-sections will be measured for payment by the month up to the time the Contract Time expires. Required inspections and reports after Contract Time has expired will not be measured for payment unless a time extension is granted by the Department.

Water Quality Sampling is measured per each. "Each" means each qualifying rainfall sampling event, not each sampled site.

When the sampling location is a receiving water, the upstream and downstream samples constitute one sample for comparison. When the sampling location is an outfall, a single outfall sample constitutes the entire sample.

**167.4.01 Limits**

General Provisions 101 through 150. Submit the monitoring summary report to the Engineer within 7 working days

**167.5 Payment**

Payment for Water Quality Inspections and Water Quality Sampling will be made as follows:

Water Quality Inspections will be paid at the Contract Price per month. This is full compensation for performing the requirements of the inspection section of the GAR100002 and this Specification, all necessary incidentals, and providing results of inspections to the Engineer, within the time frame required by the GAR100002 and this Specification.

Water Quality Sampling per each qualifying rainfall sampling event is full compensation for meeting the requirements of the sampling sections of the GAR100002 and this Specification, obtaining samples, analyzing samples, any necessary incidentals, and providing results of turbidity tests to the Engineer, within the time frame required by the GAR100002 and this Specification. This item is based on the rainfall events requiring sampling as described in Part IV.D. 6 of the GAR100002. The Department will not pay for samples taken and analyzed for rainfall events that are not qualifying events as compared to the daily rainfall data supplied by the WECS.

Payment will be made under:

Item No. 167	Water quality inspections	Per month
--------------	---------------------------	-----------

Water Quality Sampling will be paid for each qualifying rainfall sampling event.

Payment will be made under:

Item No. 167	Water quality sampling	Per each
--------------	------------------------	----------

**167.5.01 Adjustments**

General Provisions 101 through 150.

Office of Design Policy and Support

**EXHIBIT O**  
**CDBG FEDERAL/LOCAL PROJECT REQUIREMENTS**

1st Use: Nov 22, 2013

**DEPARTMENT OF TRANSPORTATION**  
**STATE OF GEORGIA**

**SPECIAL PROVISION**

**Section 171—Silt Fence**

---

*Delete Section 171 and substitute the following:*

**171.1 General Description**

This work includes furnishing, installing, and removing a water permeable filter fabric fence to remove suspended particles from drainage water.

**171.1.01 Definitions**

General Provisions 101 through 150.

**171.1.02 Related References**

**A. Standard Specifications**

[Section 163—Miscellaneous Erosion Control Items](#)

[Section 700—Grassing](#)

[Section 862—Wood Posts and Bracing](#)

[Section 881—Fabrics](#)

[Section 894—Fencing](#)

**B. Referenced Documents**

ASTM D 3786

ASTM D 4355

ASTM D 4632

ASTM D 4751

[GDT 87](#)

[QPL 36](#)

**171.1.03 Submittals**

General Provisions 101 through 150.

**171.2 Materials**

Materials shall meet the requirements of the following Specifications:

Material	Section
Filter Fabrics	<a href="#">881</a>
Fencing	<a href="#">894</a>
Wood Posts and Bracing	<a href="#">862</a>

Conditions during Project construction will affect the quantity of the silt fence to be installed.

**EXHIBIT O**  
**CDBG FEDERAL/LOCAL PROJECT REQUIREMENTS**

The Engineer may increase, decrease, or eliminate the quantity at his or her direction. Variations in quantity do not change in details of construction or in the character of the work.

For Type A, B, and C fences, use fabric as specified in [Subsection 881.2.07, "Silt Fence Filter Fabric."](#)

**171.2.01 Delivery, Storage, and Handling**

During shipment and storage, wrap the fabric in a heavy-duty covering protecting the cloth from sunlight, mud, dust, dirt, and debris. Do not expose the fabric to temperatures greater than 140 °F (60 °C).

When installed, the Engineer will reject the fabric if it has defects, rips, holes, flaws, deterioration, or damage incurred during manufacture, transportation, or storage.

**171.3 Construction Requirements**

**171.3.01 Personnel**

General Provisions 101 through 150.

**171.3.02 Equipment**

General Provisions 101 through 150.

**171.3.03 Preparation**

General Provisions 101 through 150.

**171.3.04 Fabrication**

General Provisions 101 through 150.

**171.3.05 Construction**

Install the silt fence according to this Specification, as shown on the Plans, or as directed by the Engineer

**A. Install Silt Fence**

1. Install silt fence by either of the following methods:
  - a. Excavated Trench Method  
Excavate a trench 4 to 6 in (100 to 150 mm) deep using equipment such as a trenching machine or motor grader. If equipment cannot be operated on the site, excavate the trench by hand.
  - b. Soil Slicing Method  
Create a mechanical slice in the soil 8 to 12 in (200 to 300 mm) deep to receive the silt fence. Ensure the width of the slice is not more than 3 in (75 mm). Mechanically insert the silt fence fabric into the slice in a simultaneous operation with the slicing ensuring consistent depth and placement.
2. Install the first post at the center of the low point (if applicable). Space the remaining posts a maximum of 6 ft (1.8 m) apart for Types A and B fence and 4 ft (1.2 m) apart for Type C fence.
3. Bury the posts at least 18 in (450 mm) into the ground. If this depth cannot be attained, secure the posts enough to prevent the fence from overturning from sediment loading.
4. Attach the filter fabric to the post using wire, cord, staples, nails, pockets, or other acceptable means.
  - a. Staples and Nails (Wood Posts): Evenly space staples or nails with at least five per post for Type A fence and four per post for Type B fence.
  - b. Pockets: If using pockets and they are not closed at the top, attach the fabric to a wood post using at least one additional staple or nail, or to a steel post using wire. Ensure the additional attachment is within the top 6 in (150 mm) of the fabric.
  - c. Install the filter fabric so 6 to 8 in (150 to 200 mm) of fabric is left at the bottom to be buried. Provide a minimum overlap of 18 in (450 mm) at all splice joints.
  - d. For Type C fence:
    - 1) Woven Wire Supported
      - Steel Post: Use wire to attach the fabric to the top of the woven wire support fence at the midpoint between posts. Also, use wire to attach the fabric to the post.
    - 2) Polypropylene Mesh Supported
      - Wood Post: Use at least six staples per post. Use two staples in a crisscross or parallel pattern to secure the top portion of the fence. Evenly space the remaining staples down the post.
      - Steel Post: Use wire to attach the fabric and polypropylene mesh to the post.



**EXHIBIT O**  
**CDBG FEDERAL/LOCAL PROJECT REQUIREMENTS**

5. Install the fabric in the trench so 4 to 6 in (100 to 150 mm) of fabric is against the side of the trench with 2 to 4 in (50 to 100 mm) of fabric across the bottom in the upstream direction.
6. Backfill and compact the trench to ensure flow cannot pass under the barrier. When the slice method is used, compact the soil disturbed by the slice on the upstream side of the silt fence first, and then compact the downstream side.
7. When installing a silt fence across a waterway producing significant runoff, place a settling basin in front of the fence to handle the sediment load, if required. Construct a suitable sump hole or storage area according to [Section 163](#).

**B. Remove the Silt Fence**

1. Keep all silt fence in place unless or until the Engineer directs it to be removed. A removed silt fence may be used at other locations if the Engineer approves of its condition.
2. After removing the silt fence, dress the area to natural ground, grass and mulch the area according to [Section 700](#).
3. The silt fence shall remain until the Project is accepted or until the fence is removed. Also, remove and dispose of the silt accumulations at the silt fence.
4. Remove and replace any deteriorated filter fabric reducing the effectiveness of the silt fence.
5. Repair or replace any undermined silt fence at no additional cost to the Department.

**171.3.06 Quality Acceptance**

Approved silt fence is listed in [QPL 36](#). Approved fabrics must consistently exceed the minimum requirements of this Specification as verified by the Office of Materials and Research. The Office of Materials and Research will remove fabric failing to meet the minimum requirements of this specification from the QPL until the products' acceptability has been reestablished to the Department's satisfaction.

At the time of installation, the Engineer will reject the fabric if it has defects, rips, holes, flaws, deterioration, or damage incurred during manufacture, transportation, or storage.

**171.3.07 Contractor Warranty**

The silt fence shall remain until the Project is accepted or until the fence is removed. Also, remove and dispose of the silt accumulations at the silt fence.

Remove and replace any deteriorated filter fabric that reduces the effectiveness of the silt fence.

Repair or replace any undermined silt fence at no additional cost to the Department.

**171.4 Measurement**

The quantity of silt fence to be paid for is the actual number of linear feet (meters) of silt fence, measured in place from end post to end post of each separate installation. The silt fence must be complete and accepted.

**171.4.01 Limits**

General Provisions 101 through 150.

**171.5 Payment**

Silt fence Type A, B, or C measured as defined in [Subsection 171.4, "Measurement,"](#) is paid for at the Contract Unit Price bid per linear foot (meter).

Payment is full compensation for the following:

- Furnishing materials
- Erecting the fence
- Dressing and grassing, when required
- Removing the fence, when required

Payment for this Item is made as follows:

- Seventy-five percent of the Contract Price bid per linear foot (meter) is paid when each fence is complete in place.
- Twenty-five percent is paid at removal or acceptance.

If the silt fence must be repaired or removed, as the result of neglect or damage, perform the work at no additional cost to the Department.

**EXHIBIT O**  
**CDBG FEDERAL/LOCAL PROJECT REQUIREMENTS**

Payment will be made under:

Item No. 171	Silt fence, type_	Per linear foot (meter)
--------------	-------------------	-------------------------

**171.5.01 Adjustments**

General Provisions 101 through 150.

Office of Design Policy and Support

**EXHIBIT O**  
**CDBG FEDERAL/LOCAL PROJECT REQUIREMENTS**

First Use: December 13, 2013

**DEPARTMENT OF TRANSPORTATION**  
**STATE OF GEORGIA**

**SUPPLEMENTAL SPECIFICATION**

**Section 201 – Clearing and Grubbing Right of Way**

---

*Delete Subsection 201.3.05.E.3 and substitute the following:*

3. Solid Waste Material

a. Nonregulated Material

- 1) Common fill is defined as soil, rock, brick, concrete without reinforcement, concrete with reinforcement where the reinforcement has been removed flush with the surface of the concrete and cured asphalt, provided that such material does not contain hazardous waste constituents above background levels and the material results from Department funded construction contracts. Such fill is not subject to the Georgia Comprehensive Solid Waste Management Act of 1990 and the Solid Waste Management Rules when used as fill material on Department funded construction contracts or Department property or when used as fill material on property not owned by the Department when all requirements of this specification are fully met. Common fill meeting this definition may be placed as follows:

- a. At a permitted municipal, construction and demolition materials or inert landfill fully meet all requirements of the Solid Waste Rules and Act and any other applicable laws or ordinances.
- b. At an off-site engineered fill location in accordance with the following requirements.

Place the material in uniform layers 3 ft thick or less and distributed to avoid the formation of large voids or pockets.  
Fill voids with finer material.

Cover the last layer of fill with at least 2 ft of soil.

Construct the fill according to Section 208, except compact it to at least 90 percent of the maximum laboratory dry density.

A Georgia registered professional engineer shall document, certify and submit the following information on behalf of the Contractor to the Department; compaction rates, waste description including average particle size, and the depth of clean earthen fill lying above the engineered fill.

**EXHIBIT O**  
**CDBG FEDERAL/LOCAL PROJECT REQUIREMENTS**

Revised: November 5, 2013  
 First Use: December 13, 2013

cO On site as compacted fill if prior written approval has been granted by the Engineer and in accordance with the following requirements: As compacted fill incorporated into embankment only. No area shall be excavated for the sole purpose of disposing of common fill.

- Place the material in uniform layers 3 ft thick or less and distribute it to avoid the formation of large voids or pockets.
- Fill voids with finer material.
- Cover the last layer of fill with at least 2 ft of soil.  
Construct the fill according to Section 208, except compact it to at least 90 percent of the maximum laboratory dry density.
- Records of the exact location by station and offsets, amount disposed per location in cubic yards, waste description including average particle size, compaction rates and depth of clean earthen fill lying above the composite materials shall be kept by the Engineer.

d. Materials that may be recycled or reused such as asphaltic concrete, Portland cement concrete, plastic, metal and materials that qualify under EPD regulations for sale or use may be reclaimed by the Contractor.

b. Regulated Material

- 1) Inert waste is defined as organic debris such as stumps, limbs, and leaves, cured asphalt and any of the aforementioned common fill items that do not meet the compaction requirements when placed in an excess materials pit. An inert waste landfill permit shall be obtained in accordance with GDNR/EPD Rules to properly record the disposal of inert waste when compaction requirements are not met at an excess materials pit. If disposed of at a landfill, inert waste may only be disposed at a permitted municipal, construction and demolition materials or inert landfill fully meeting all requirements of the Solid Waste Rules and Act and any other applicable laws or ordinances.
- 2) Construction and demolition waste is defined as construction forms, barrels, scrap metal, and other such by-products of construction not specifically listed above as either common fill or inert waste. Construction and or demolition waste must be disposed of at a permitted municipal, construction and demolition materials, or inert landfill fully meeting all requirements of the Solid Waste Rules and Act and any other applicable laws or ordinances.
- 3) Dispose of oils, solvents, fuels, untreated lead paint residue, and other solid hazardous waste through a properly licensed hazardous waste disposal facility.

**EXHIBIT O**  
**CDBG FEDERAL/LOCAL PROJECT REQUIREMENTS**

Revised: November 5, 2013  
 First Use: December 13, 2013

- 4) Remove municipal solid waste discovered during construction or shown on the Plans according to Section 215.

c. Solid Waste Handling and Disposal Documentation Requirements:

- 1) Waste disposed at a permitted municipal or construction and demolition landfill – all tipping receipts generated by the receiving landfill shall be provided to the Engineer.
- 2) Waste disposed at inert landfill – a copy of the landfill’s Permit By Rule notification, and for landfills exceeding one acre, a copy of the landfill’s NPDES General Storm water Permit Notice of Intent (NOI) and any local jurisdiction Land Disturbing Activity Permit, if applicable, shall be provided to the Engineer.
- 3) Any necessary documentation regarding a disposal site’s permit status must be obtained by the Contractor and verified by the Department before any common fill, inert waste, or other solid waste is allowed to leave the site.
- 4) The documentation listed herein shall be maintained on-site in the project files and at any other location the Department deems necessary until a valid NPDES Notice of Termination is filed.

Recyclable materials must be separated from all waste materials and shall be properly stored in containers when practicable.

Excluding the above allowances, all types of waste shall be handled in full compliance with the following:

- The Georgia Solid Waste Management Rules, as amended (391-3-4)
- Georgia Comprehensive Solid Waste Management Act of 1990, as amended (O.C.G.A. 12-8-20)
- The Georgia Erosion & Sedimentation Act as amended (O.C.G.A. 12-7-1) and any applicable Local and State requirements as well as the General Permits of the Georgia Water Quality Control Act
- Any other applicable Federal, State, or Local rules or laws

Office of Construction